



SEMESTER PROJECT

A journey around mapping class groups and their presentations

Supervisor:
DR. CHRISTIAN URECH

Author:
MARIE ABADIE

DEPARTMENT OF MATHEMATICS

Spring Semester 2022

Contents

Introduction	3
1 A short walk along braid group	5
1.1 First definitions	5
1.2 The pure braid group is torsion free	6
1.3 Braid groups and mapping class groups	10
2 Around the Lickorish-Wallace theorem	14
2.1 Basic concepts	14
2.2 Technical lemmata	16
2.3 Generating the mapping class group	20
2.4 The Lickorish-Wallace theorem	23
3 Presentation of the mapping class group of a surface	25
3.1 The mapping class group is finitely generated	25
3.1.1 Basic definitions and background	26
3.1.2 Sketch of the proof	28
3.1.3 Toolbox for the proof	31
3.2 The mapping class group is finitely presented	32
3.2.1 Relations	32
3.2.2 Proof of finite presentability	35
4 The Complex of curves	38
References	39

Introduction

The present semester project intends to explore the notion of mapping class groups of surfaces and, more specifically, to investigate presentations of the mapping class groups. However, we regularly take some breaks to study some interesting objects or results that appear in the landscape around mapping class groups.

In the first section, we briefly introduce the notion of braid groups. It represents how strings can be braided. To illustrate the definition we give a proof of the fact that the pure braid group is torsion free. Along the way, we identify the braid group on n strings as the group of loops in the space of (unordered) n -tuples. In fact, this identification permits us to cross the bridge, built at the beginning of the 1970's by Joan Birman and Hugh Hilden, between the theory of the braid group and the theory of mapping class groups. The mapping class group of a space is the group of ways to stretch and deform the space continuously (more precisely, it is the group of isotopy classes of homeomorphisms). By using the previous identification, one can see the braid group as the mapping class group of a punctured disk.

Once the bridge is crossed, in the second section, we start studying the mapping class group of a surface. It appeared in the first half of the twentieth century, particularly in the work of Max Dehn and Jakob Nielsen. Our main quest is to explore a presentation of the mapping class group of a surface. We follow the path traced by W. B. R. Lickorish in [Lic64] to show that the mapping class group of a surface is generated by a nice family of classes of homeomorphisms called the Dehn twists. Lickorish encourages us to make a detour to see a nice theorem, which states that every compact closed 3-manifold can be obtained from the 3-sphere, by removing tori from S^3 and sewing them back on differently

In the third section we focus on our principal quest. After finding a family of generators for the mapping class group of a surface in the second section we naturally come to study the finite presentability of the mapping class group. Our guide for this walk is [FM12]. We start by showing that the mapping class group of a surface with no boundary and no punctures is finitely generated by Dehn twists. Then we use a beautiful argument based on geometric group theory to show finite presentability.

In the previous section, we meet an interesting space attached to a surface, the arc complex. We end our walk by studying in [HPW13] the fact that the arc complex is 7-hyperbolic. This is an interesting property of the geometry of the arc complex space saying that geodesic triangles are thin. Moreover, the complex of curves, a close cousin to the arc complex, shares a similar property: it is 17-hyperbolic. The motivation to study the geometry of the complex of curves is that it helps us to understand the geometry, and hence the algebraic properties, of the mapping class group through its isometric action on the complex of curves. See the series of papers from Ursula Hamenstaedt to go further and the work of Masur-Minsky [MM99].

Remark

The present notes summarise the work I did for my semester project supervised by Dr. Christian Urech. The main proofs at the end of the third section and in the last section were presented in class but are not written here (yet, maybe in a next life).

Acknowledgements

I would like to thank my supervisor Dr.Christian Urech for proposing the topic of this semester project, for his continued support, his friendly listening and for introducing me to algebraic topology.

1 A short walk along braid group

1.1 First definitions

We denote \mathbb{D}^2 the unit disk with centre zero in the plane \mathbb{R}^2 , and I the interval $[0, 1]$ in \mathbb{R} .

Definition 1.1. A *geometric braid* on n strings is an embedding of n disjoint curves homeomorphic to the interval I , called the *strings*, into $\mathbb{R}^2 \times [0, 1]$,

$$\beta : \{1, \dots, n\} \times [0, 1] \longrightarrow \mathbb{R}^2 \times [0, 1]$$

such that:

- $\{\beta(k, 0) \mid k \in \{1, \dots, n\}\} \cap (\mathbb{R}^2 \times [0, 1]) = \{(1, 0, 0), \dots, (n, 0, 0)\}$ and $\{\beta(k, 1) \mid k \in \{1, \dots, n\}\} \cap (\mathbb{R}^2 \times [0, 1]) = \{(1, 0, 1), \dots, (n, 0, 1)\}$.
- Each string $\{\beta(k, t) \mid t \in [0, 1]\}$ meets each plane $\mathbb{R}^2 \times \{t\}$ in exactly one point.

Definition 1.2. Two geometric braids on n strings β and β' are *isotopic* if β can be continuously deformed into β' . That is, there exists a continuous map $F : \{1, \dots, n\} \times [0, 1] \times I \longrightarrow \mathbb{R}^2 \times [0, 1]$ such that $H(-, -, s)$ is a geometric braid on n strings at each time $s \in I$, $F(-, -, 0) = \beta$ and $F(-, -, 1) = \beta'$. Moreover the endpoints of the strings are fixed by all $F(-, -, s)$.

Definition 1.3. To each geometric braid β on n strings we associate a *braid diagram* on n strands that is given by the composition of β with the projection onto $\mathbb{R} \times 0 \times I$. Each point of the diagram lies on at most two strands and the endpoints belong to exactly one strand.

Remark 1.4. Each string in a braid on n strings connects a point $(i, 0, 0)$ to a point $(s(i), 0, 1)$ where $s \in \mathfrak{S}_n$ is a permutation; called the *underlying permutation* of the braid.

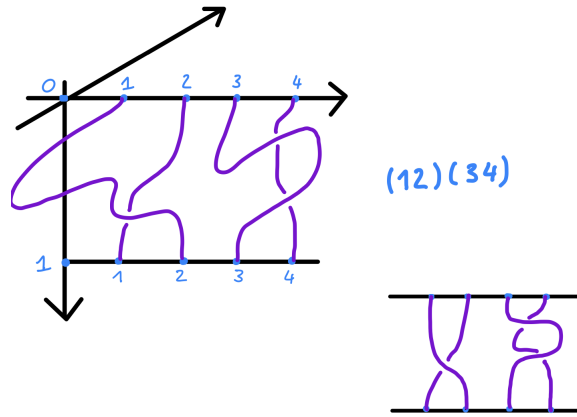

Figure 1: A geometric braid with its diagram and its permutation, the vertical arrow is I and the horizontal arrows represent \mathbb{R}^2 .

Definition 1.5. The product of two geometric braids on n strings β and β' is a geometric braid:

$$\{1, \dots, n\} \times [0, 1] \longrightarrow \mathbb{R}^2 \times [0, 1]$$

$$(k, t) \longmapsto \begin{cases} \beta(k, 2t) & \text{if } t \in [0, \frac{1}{2}] \\ \beta(k, 2t - 1) & t \in [\frac{1}{2}, 1] \end{cases}$$

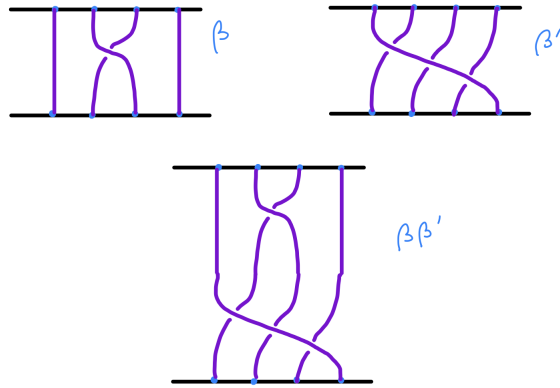

Figure 2: Product of two braids

See Figure 2.

Definition 1.6. The *group of geometric braids* on n strings, denoted \mathcal{B}_n , is the set of isotopy classes of geometric braids on n string with the product defined above. See [Chr08].

Remark 1.7. During a presentation in class, we showed that The Braid group on n strings (1.6) is isomorphic to the group with the following presentation:

$$\left\langle \sigma_1, \dots, \sigma_n \mid \begin{array}{ll} \sigma_i \sigma_j = \sigma_j \sigma_i & \forall i, j = 1, \dots, n, |i - j| > 2 \\ \sigma_i \sigma_{i+1} \sigma_i = \sigma_{i+1} \sigma_i \sigma_{i+1} & \forall i, j = 1, \dots, n - 2 \end{array} \right\rangle$$

Definition 1.8. The kernel of the surjective morphism

$$\pi : \mathcal{B}_n \longrightarrow \mathfrak{S}_n$$

which associates to a braid its underlying permutation is called the *Pure braid group*

1.2 The pure braid group is torsion free

We start with a few words about configuration spaces and braid groups. Let M be a topological space.

Definition 1.9. The configuration space of n points in M is the set of n -tuples of pairwise distinct points in M :

$$\text{Conf}_n(M) := \{(u_1, \dots, u_n) \in M^n \mid u_i \neq u_j \forall i \neq j\}.$$

Consider the case where $M = \mathbb{R}^2$. Then, we identify the fundamental group of its configuration space of n points with the group of pure braid with n strings, that is:

$$\pi_1(\text{Conf}_n(\mathbb{R}^2)) \cong P\mathcal{B}_n.$$

To see this, consider a loop $\gamma : I \longrightarrow \text{Conf}_n(\mathbb{R}^2)$, $\gamma(t) := (\alpha_1(t), \dots, \alpha_n(t)) \in (\mathbb{R}^2)^n$ which starts and ends at the point $e_n = ((1, 0), \dots, (n, 0))$. By following the movement of each point along the path γ , we obtain $\beta \subset \mathbb{R}^2 \times I$ a well-defined pure braid with n strings:

$$\beta(k, t) = (\alpha_k(t), t).$$

Conversely, given a pure geometric braid with n strings one can build a loop γ in the configuration space of n points of \mathbb{R}^2 where each coordinate γ^i of the loop is given by the curve of the i th string. This loop is based at e_n since we started with a pure braid. It is well defined in the configuration space since all the curves of the geometric braid are disjoint. The isotopy class of β does not depend on choice of γ . A homotopy $H : \text{Conf}_n(\mathbb{R}^2) \times \mathbf{I} \rightarrow \text{Conf}_n(\mathbb{R}^2)$, from $\gamma = H(-, 0)$ to another loop, corresponds to an isotopy: $F : \{1, \dots, n\} \times [0, 1] \times \mathbf{I} \rightarrow \mathbb{R}^2 \times [0, 1] (k, t, s) \mapsto (H^k(t, s), t)$

One can show that if one forgets the order of the points in the n -tuple, i.e. if one mods out the symmetric group, we obtain a group isomorphism:

$$\pi_1 \left(\frac{\text{Conf}_n(\mathbb{R}^2)}{\mathfrak{S}_n} \right) \cong \mathcal{B}_n.$$

Using this new definition of braid groups via the notion of configuration spaces, we will prove the following property of braid groups:

Proposition 1.10. *The group of pure braids is torsion free.*

The proof uses the fact that the configuration space is an Eilenberg–MacLane space of rank one and is finite dimensional.

First, we begin with a lemma.

Lemma 1.11. *Let G be a group such that the associated Eilenberg–MacLane space X of type $K(G, 1)$ is finite dimensional. Then G is torsion free.*

Proof. By contradiction, we assume that G is not torsion free. Hence G has a non-trivial finite cyclic subgroup, isomorphic to $\mathbb{Z}/m\mathbb{Z}$ for some integer m . By the Galois correspondence, this subgroup corresponds to an m -fold covering $\tilde{X} \rightarrow X$. The covering map induces an isomorphism on the homotopy groups of degree ≥ 2 . Consequently, \tilde{X} is a $K(\mathbb{Z}/m\mathbb{Z}, 1)$. Hence, it is weakly homotopy equivalent to an infinite lens space. We obtain a contradiction: homology groups of \tilde{X} vanish above its dimension whereas the lens space has non trivial homology in infinitely many degrees. \square

Now we prove the proposition.

Proof of Proposition 1.10. Define the map

$$\begin{aligned} \rho : \text{Conf}_{n+1}(\mathbb{R}^2) &\longrightarrow \text{Conf}_n(\mathbb{R}^2) \\ (z_1, \dots, z_{n+1}) &\longmapsto (z_1, \dots, z_n). \end{aligned}$$

on the fundamental groups, it induces the map $\rho : P\mathcal{B}_{n+1} \rightarrow P\mathcal{B}_n$ that forgets the $(n+1)$ th string of a pure geometric braid. Now, we study the fiber of ρ . Take a point (z_1, \dots, z_n) in $\text{Conf}_n(\mathbb{R}^2)$, then observe:

$$\begin{aligned} \rho^{-1}((z_1, \dots, z_n)) &= \{(z_1, \dots, z_n, y_{n+1}) \in \text{Conf}_{n+1}(\mathbb{R}^2)\} \\ &\cong \mathbb{C} - \{z_1, \dots, z_n\} =: \mathbb{C}_n. \end{aligned}$$

We claim that the map ρ is a fibration. To prove this, we show that $(\text{Conf}_{n+1}(\mathbb{R}^2))$ is a fiber bundle over $\text{Conf}_n(\mathbb{R}^2)$ with fiber \mathbb{C}_n . Take a point $\tilde{x} = (x_1, \dots, x_n) \in \text{Conf}_n(\mathbb{R}^2)$. Then

the x_i 's are all distinct so one can choose pairwise distinct neighbourhoods U_1, \dots, U_n in \mathbb{R}^2 . Then, $\tilde{U} = U_1 \times \dots \times U_n$ is a neighbourhood of \tilde{x} in $\text{Conf}_n(\mathbb{R}^2)$. We show that it is a trivializing neighbourhood, i.e. the map ρ is a trivial fibre bundle over \tilde{U} . Observe that

$$\tilde{V} := \rho^{-1}(\tilde{U}) = \{y = (y_1, \dots, y_n, y_{n+1}) \in \text{Conf}_{n+1}(\mathbb{R}^2) \mid y_i \in U_i \forall i = 1, \dots, n\}.$$

Now we need to find a map $\phi : \tilde{V} \rightarrow \tilde{U} \times \mathbb{C}_n$ such that the following diagram commutes

$$\begin{array}{ccc} \tilde{V} & \xrightarrow{\phi} & \tilde{U} \times \mathbb{C}_n \\ \rho \downarrow & \swarrow \text{proj}_2 & \\ \tilde{U} & & \end{array}$$

where $\text{proj}_2 : \tilde{U} \times \mathbb{C}_n \rightarrow \tilde{U}$ is the natural projection. Take a point $a \in U_i$, let $\phi_i(a, -)$ be a homeomorphism on $\tilde{U}_i \cong \mathbb{D}^n$ fixing the boundary and sending a to x_i . This extends to a homeomorphism on all \mathbb{R}^2 that is the identity outside U_i . For each i , we get a continuous family of homeomorphisms parametrized by U_i . In total, we have

$$\{\phi_i : U_i \times \mathbb{R}^2 \rightarrow \mathbb{R}^2\}_{i=1, \dots, n}.$$

Finally, ϕ is defined as follows:

$$\begin{aligned} \phi : \tilde{V} = \rho^{-1}(\tilde{U}) &\rightarrow \tilde{U} \times \mathbb{C}_n \\ y = (y_1, \dots, y_n, y_{n+1}) &\mapsto (y_1, \dots, y_n, \phi_1(y_1, -) \circ \dots \circ \phi_n(y_n, -)(y_{n+1})). \end{aligned}$$

This is well defined. Indeed, for $y \in \text{Conf}_{n+1}(\mathbb{R}^2)$, the point y_{n+1} is distinct from all the y_i 's, $i \leq n$. Moreover, $\phi_i(y_i, -)$ is the identity outside of U_i . Thus, if y_{n+1} is in one of the U_i 's, say U_j , then $\phi_i(y_i, -)$ fixes y_{n+1} for each $i \neq j$ and only $\phi_j(y_j, -)$ moves it, sending it to a point in U_j but distinct from x_j . This shows that $\phi(y)$ is indeed in $\tilde{U} \times \mathbb{C}_n$. The map ϕ is a homeomorphism, with inverse given by

$$(y_1, \dots, y_n, y_{n+1}) \mapsto (y_1, \dots, y_n, \phi_1(y_1, -)^{-1} \circ \dots \circ \phi_n(y_n, -)^{-1}(y_{n+1})).$$

This concludes the proof that ρ is a fiber bundle.

Since the map ρ is a fibration, it induces a long exact sequence on homotopy groups:

$$\dots \rightarrow \pi_k(\mathbb{C}_n) \rightarrow \pi_k(\text{Conf}_{n+1}(\mathbb{R}^2)) \rightarrow \pi_k(\text{Conf}_n(\mathbb{R}^2)) \rightarrow \pi_{k-1}(\mathbb{C}_n) \dots$$

Note that $\pi_k(\mathbb{C}_n) = 1$ for all $k \neq 1$. From the previous sequence one deduces that:

$$\pi_k(\text{Conf}_{n+1}(\mathbb{R}^2)) \cong \pi_k(\text{Conf}_n(\mathbb{R}^2)) \text{ for all } k > 1.$$

Now, for $n = 1$ one has $\pi_k(\text{Conf}_1(\mathbb{R}^2)) = \pi_k(\mathbb{R}^2) = 1$, thus

$$\pi_k(\text{Conf}_n(\mathbb{R}^2)) = 1 \text{ for all } n \geq 1, k > 1.$$

Hence $\text{Conf}_n(\mathbb{R}^2)$ is an Eilenberg–MacLane space of type $K(P\mathcal{B}_n, 1)$. We conclude by using Lemma 1.11. \square

Corollary 1.12. *The braid group is torsion free.*

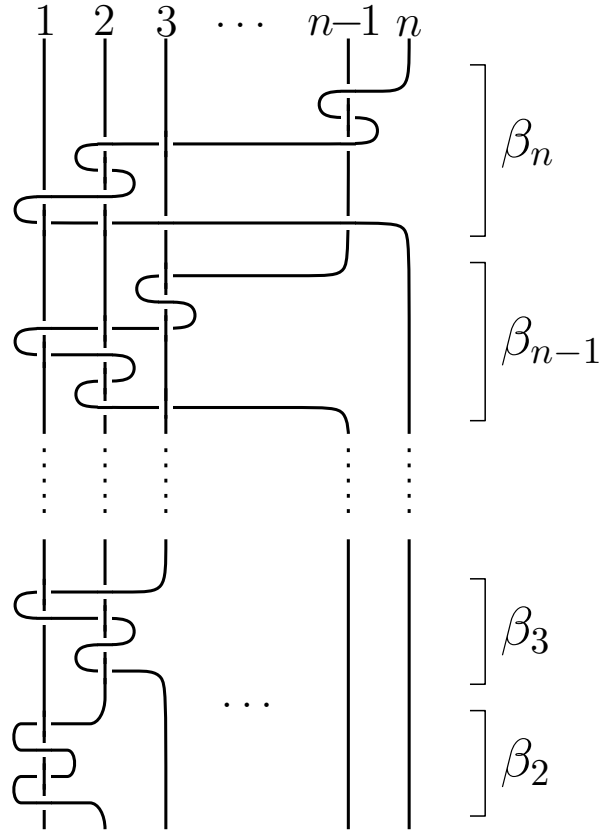

Figure 3: Combed form of a pure braid.

Proof. We observe that $\text{Conf}_n(\mathbb{R}^2)$ is an $n!$ -fold covering of $\frac{\text{Conf}_n(\mathbb{R}^2)}{\mathfrak{S}_n}$. The covering map induces an isomorphism on the homotopy groups with rank ≥ 2 . Hence we deduce that $\frac{\text{Conf}_n(\mathbb{R}^2)}{\mathfrak{S}_n}$ is a $K(\mathcal{B}_n, 1)$ and the result follows. \square

From the previous proof we see another nice result about pure braid groups. Indeed each geometric pure braid can be written in a *combed form* as shown on figure 1.2.

More formally, we have:

Proposition 1.13. *Every geometric pure braid with n strings can be written as:*

$$\beta = \beta_2 \beta_3 \dots \beta_n, \text{ where } \beta_j \in P\mathcal{B}_j \subseteq P\mathcal{B}_n.$$

This decomposition is called the combed form of β .

Proof. This can be shown by looking at the first terms of the long exact sequence on homotopy groups given in the proof the Proposition 1.10:

$$\begin{array}{ccccccc}
 & & \dots & \longrightarrow & 1 = \pi_2(\text{Conf}_n(\mathbb{R}^2)) & \longrightarrow & \\
 & \longleftarrow & \pi_1(\mathbb{C}_n) & \longrightarrow & \pi_1(\text{Conf}_{n+1}(\mathbb{R}^2)) & \longrightarrow & \pi_1(\text{Conf}_n(\mathbb{R}^2)) \\
 & \longleftarrow & \pi_0(\mathbb{C}_n) = 1 & \longrightarrow & \pi_0(\text{Conf}_{n+1}(\mathbb{R}^2)) & \longrightarrow & \pi_0(\text{Conf}_n(\mathbb{R}^2)) \longrightarrow 0
 \end{array}$$

Note that the configuration spaces and \mathbb{C}_n are connected. We already identified the first two fundamental groups as the pure braid groups with $n + 1$ and n strings. The fundamental group of the n times punctured complex plane is the free group on n generators, denoted by F_n . Observe that $\pi_2(\text{Conf}_1(\mathbb{R}^2)) = \pi_2(\mathbb{R}^2) = 1$. Taking $n = 1$ in the previous sequence we obtain that $\pi_2(\text{Conf}_2(\mathbb{R}^2)) = 1$. Hence, by induction, $\pi_2(\text{Conf}_n(\mathbb{R}^2)) = 1$ for all $n \geq 2$ (or simply use the fact that it is an Eilenberg-MacLane space). Thus we have the following short exact sequence:

$$1 \longrightarrow F_n \longrightarrow P\mathcal{B}_{n+1} \xrightarrow{\rho} P\mathcal{B}_n \longrightarrow 1$$

Then, let $s : P\mathcal{B}_n \longrightarrow P\mathcal{B}_{n+1}(\mathbb{R}^2)$ be the map that adds a vertical $(n + 1)$ -th string. This defines a section of ρ , hence the previous short exact sequence splits and one has:

$$P\mathcal{B}_{n+1} \cong F_n \rtimes P\mathcal{B}_n.$$

We conclude by induction. □

1.3 Braid groups and mapping class groups

Here we introduce the notion of mapping class groups and we explain how we can interpret the braid group as the mapping class group of a particular space.

Let M be an oriented topological manifold (possibly with boundary ∂M). Let Q be a finite subset in the interior of M .

Definition 1.14. A *self-homeomorphism* of (M, Q) , is an orientation preserving homeomorphism from M to itself that fixes the boundary of M pointwise and Q setwise. The set of self-homeomorphisms of (M, Q) is denoted by $\text{SelfHom}(M, Q)$.

Remark 1.15. A self-homeomorphism of (M, Q) induces a permutation on Q .

Definition 1.16. Two self-homeomorphisms f and g are *isotopic* if there exists a family $(H_t)_{t \in [0,1]}$ of self-homeomorphisms of (M, Q) such that $H_0 = f$ and $H_1 = g$ and the map

$$M \times [0, 1] \longrightarrow M, (x, t) \longmapsto H_t(x)$$

is continuous. It is straightforward that, being isotopic defines an equivalence relation.

Definition 1.17. The mapping class group of (M, Q) , denoted $\text{Mod}(M, Q)$, is the group of isotopy classes of self-homeomorphisms of (M, Q) . We write $\text{Mod}(M) := \text{Mod}(M, \emptyset)$.

Example 1.18. An important example is the mapping class group of the closed unit ball of dimension $n \geq 0$:

$$\text{Mod}(D^n) \text{ is trivial.}$$

This follows from the *Alexander trick*, which states that the self-homeomorphisms of D^n are all isotopic to the identity. Indeed, let f be element of $\text{Mod}(D^n)$. Then one defines:

$$H_t(z) = \begin{cases} z & \text{if } t \leq |z| \leq 1 \\ tf(\frac{z}{t}) & \text{if } |z| < 1 \end{cases}$$

which is an isotopy from $H_0 = \text{id}$ to $H_1 = f$. See Figure 4 for an illustration of the isotopy. △

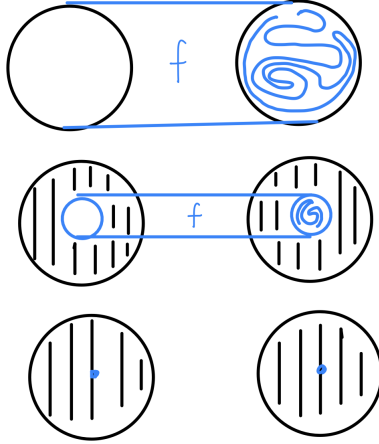

Figure 4

Definition 1.19. Let α be a subset of M homeomorphic to $[0, 1]$, with interior disjoint from $Q \cup \partial M$ and such that the end points lie on Q . The *half-twist*, $\tau_\alpha : (M, Q) \rightarrow (M, Q)$ is the homeomorphism obtained at the end of the isotopy that starts with the identity map $\text{id} : M \rightarrow M$ and rotate with an angle π , the segment α in M around its midpoint in the direction provided by the orientation of M .

Remark 1.20. Note that $\tau_\alpha(\alpha) = \alpha$ and τ_α is the identity outside a neighbourhood of α . Moreover, $\tau_\alpha(Q) = Q$ and τ_α induces a permutation on Q that permutes the end points of α .

Example 1.21. Consider $\alpha = [-\frac{1}{2}, \frac{1}{2}]$ in \mathbb{C} and U the unit disk. The following homeomorphism:

$$\tau_\alpha : \mathbb{C} \rightarrow \mathbb{C}$$

$$z \mapsto \begin{cases} z & \text{if } z \notin U \\ -z & \text{if } |z| \leq \frac{1}{2} \\ ze^{-2\pi i|z|} & \text{if } \frac{1}{2} \leq |z| < 1. \end{cases} .$$

is a half-twist. Figure 5 illustrates the action of τ_α on a curve that intersects α transversely

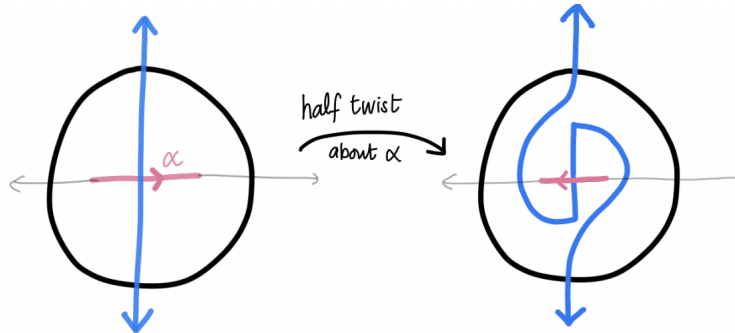

Figure 5

at one point. One can also imagine that the neighbourhood of α is a viscous fluid and when

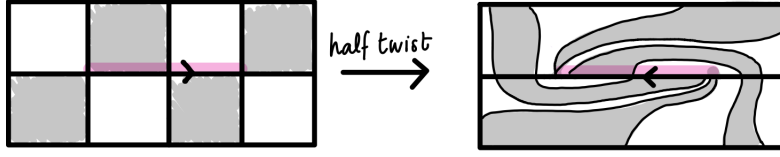

Figure 6

we rotate α we also drag this fluid. See Figure 6. △

Proposition 1.22. *Let \mathbb{D}^2 be the closed 2-disk and let $Q_n = \{x_1, \dots, x_n\}$ be a collection of n distinct points in \mathbb{D}^2 . The braid group \mathcal{B}_n is isomorphic to $\text{Mod}(\mathbb{D}^2, \{x_1, \dots, x_n\})$.*

Proof. Consider the following sequence of maps:

$$\text{SelfHom}(\mathbb{D}^2, Q_n) \longrightarrow \text{SelfHom}(D^2) \longrightarrow \frac{\text{Conf}_n(\mathbb{D}^2)}{\mathfrak{S}_n}$$

where the first map is just the inclusion and the second map is given by:

$$\begin{aligned} \text{eval}_Q : \text{SelfHom}(D^2) &\longrightarrow \frac{\text{Conf}_n(\mathbb{D}^2)}{\mathfrak{S}_n} \\ f &\longmapsto \{f(x_1), \dots, f(x_n)\}. \end{aligned}$$

Since the evaluation map is a fibration we can look at the first terms of the long exact sequence on homotopy groups associated to this fibration. Note that $\text{SelfHom}(D^2)$ is connected and is also contractible by the Alexander trick. By definition one has $\pi_0(\text{SelfHom}(\mathbb{D}^2, Q_n)) = \text{Mod}(\mathbb{D}^2, Q_n)$. Recall that $\pi_1\left(\frac{\text{Conf}_n(\mathbb{R}^2)}{\mathfrak{S}_n}\right) \cong \mathcal{B}_n$. Hence, one has:

$$\pi_1(\text{SelfHom}(\mathbb{D}^2)) = 1 \longrightarrow \mathcal{B}_n \xrightarrow{\cong} \text{Mod}(\mathbb{D}^2, Q_n) \longrightarrow \pi_0(\text{SelfHom}(D^2)) = 1 \longrightarrow 1.$$

□

Remark 1.23. The isomorphism is given by the connecting map (between the π_1 and the π_0 so it corresponds to the monodromy action). Take an element in $\pi_1\left(\frac{\text{Conf}_n(\mathbb{R}^2)}{\mathfrak{S}_n}\right)$ represented by a loop β that can be viewed as a braid starting and ending at the same point in \mathbb{D}^2 . See

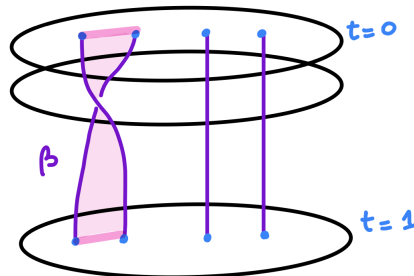

Figure 7

for instance Figure 7. Then, following the movement, during the loop, of each segment in \mathbb{D}^2 between the endpoints of β we obtain at the end an element of $\text{Mod}(\mathbb{D}^2, Q_n)$ (a half-twist in Figure 7). This is the element $\bar{\beta}$ in the following diagram given by the homotopy lifting property.

$$\begin{array}{ccc}
 & \text{SelfHom}(\mathbb{D}^2, Q_n) & \\
 & \downarrow & \\
 & \text{SelfHom}(\mathbb{D}^2) & \\
 \text{I} & \xrightarrow{\bar{\beta}} & \downarrow \text{eval}_Q \\
 & \xrightarrow{\beta} & \frac{\text{Conf}_n(\mathbb{D}^2)}{\mathfrak{S}_n}
 \end{array}$$

2 Around the Lickorish-Wallace theorem

The goal of this discussion is to present a proof of the Dehn-Lickorish theorem which states that the mapping class group of a connected closed orientable surface is generated by Dehn twists. Furthermore, we apply this theorem in the Lickorish proof of the Lickorish-Wallace Theorem [Lic62]. In the 1960's, this theorem was proven using different methods by a Scottish-American mathematician, Andrew Wallace, and a British mathematician, W.B.R. Lickorish. This theorem states that every compact closed 3-manifold can be obtained from the 3-sphere, by removing tori from \mathbb{S}^3 , then sew the tori back differently. Along the way we will introduce some basic notions relevant to the theorem and its proof (Dehn twists, handlebodies, Heegaard decompositions of 3-manifolds, etc). Here we follow closely [Lic62].

2.1 Basic concepts

Lickorish worked on combinatorial manifolds. Here we will consider the particular case of surfaces. A topological *surface* is a topological space such that every point has a neighbourhood that is homeomorphic to an open subset of a Euclidean plane. It can be shown that it is a combinatorial 2-manifold. Basic definitions such as simplicial complex, subdivisions, homeomorphisms, combinatorial manifold, can be found in [Bry01]. Here we recall the main definitions.

Definition 2.1. Let X be a topological space and $f, g : X \rightarrow X$ be two homeomorphisms. If there exists a homotopy $H : X \times I \rightarrow X$ between f and g , which is a homeomorphism at each time $t \in I$, then one says that f and g are *isotopic*.

Definition 2.2. Let S be a surface, the *mapping class group* of S is the group of isotopy classes of orientation preserving homeomorphisms. We denote it $\text{Mod}(S)$. It is the quotient of the set of orientation preserving homeomorphisms by the subset of elements isotopic to the identity.

Definition 2.3. Let S be a surface, a *curve* γ in S is a continuous function $\gamma : [0, 1] \rightarrow S$. A curve is *closed* if $\gamma(0) = \gamma(1)$. A curve is *simple* if it has no self-intersections.

Definition 2.4. Take two simple closed curves α and β . The geometric intersection number of α and β is defined by:

$$i(\alpha, \beta) := \min\{|\alpha' \cap \beta'| \mid \alpha' \in [\alpha], \beta' \in [\beta]\}$$

where $[\cdot]$ indicates the isotopy class.

Definition 2.5. Let S be surface and C be a simple closed curve in S . Take a tubular neighbourhood of C in S , i.e. a cylinder $\mathbb{S}^1 \times I$. Performing a C -homeomorphism on S consists in cutting S along C , twisting one of the ends of the neighbourhood and then gluing together the two ends. Figure 8 illustrates this process. A C -homeomorphism is also called a *Dehn twist*.

Definition 2.6. Let α and β be two curves in a surface S such that they can be obtained from each other via a sequence of C -homeomorphisms and a homeomorphism isotopic to the identity. Then we write $\alpha \sim_c \beta$. Note that \sim_c is an equivalence relation.

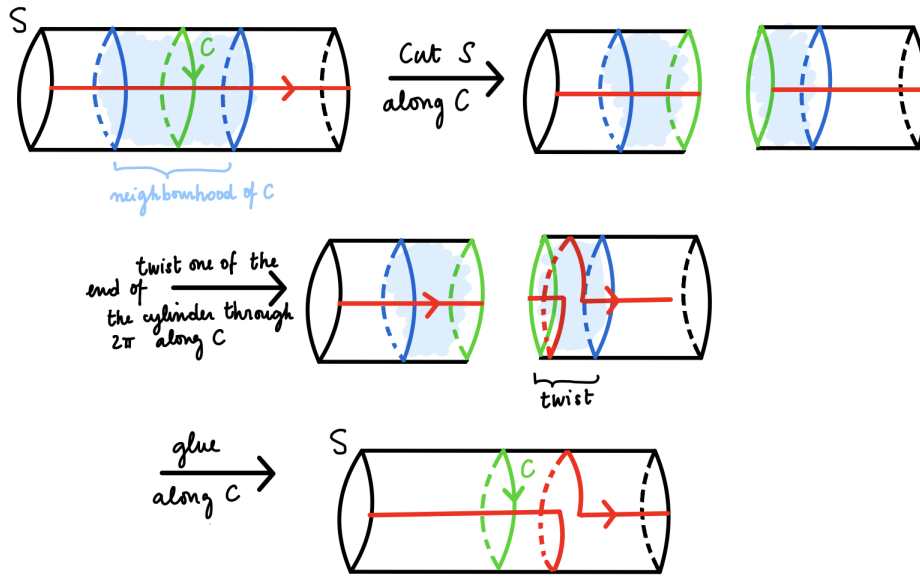

Figure 8: A Dehn Twist.

Definition 2.7. Let M be an n -manifold. *Attaching an r -handle to M* consists in gluing to M a copy of $\mathbb{D}^r \times \mathbb{D}^{n-r}$ along an embedding of $\mathbb{S}^{r-1} \times \mathbb{D}^{n-r}$ into the boundary ∂M of M . A handlebody is a 3-ball with 1-handles attached to it.

Definition 2.8. A *Heegard splitting* of a closed connected orientable 3-manifold M , is given by two handlebodies H_1 and H_2 , with same genus, such that

$$M = H_1 \cup_f H_2,$$

where f is a homeomorphism from ∂H_1 to ∂H_2 .

Theorem 2.9. *Any closed connected orientable 3-manifold has a Heegard splitting.*

Proof. See Lemma 12.12 in [Lic97]. □

Proposition 2.10. *Let M be closed connected orientable 3-manifold, with Heegard splitting $M = H_1 \cup_f H_2$. Then, there exists a homeomorphism $h : \partial H_1 \rightarrow \partial H_2$ such that $\mathbb{S}^3 \cong H_1 \cup_h H_2$.*

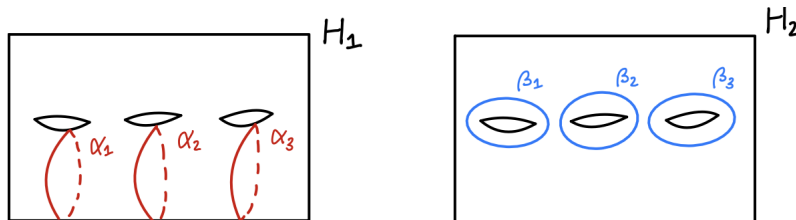

Figure 9

Proof. First, ∂H_1 and ∂H_2 are surfaces, say genus g . Let $\alpha_1, \dots, \alpha_g$ be a collection of closed meridian curves in ∂H_1 . Let β_1, \dots, β_g be a collection of closed longitudinal curves in ∂H_2 (see Figure 9). One can take a homeomorphism $h : \partial H_1 \rightarrow \partial H_2$ such that $h(\alpha_i) = \beta_i \forall i = 1, \dots, g$. Indeed, for $g = 1$ it is clear, for other g , write H_1 and H_2 as a connected sum of g tori, $\#_i T_{\alpha_i}$ and $\#_i T_{\beta_i}$. Choose h that maps the excluded disk in the connected sum of T_{α_i} to the the excluded disk in the connected sum of T_{β_i} . Then, one has $H_1 \cup_h H_2 = \mathbb{S}^3$. \square

2.2 Technical lemmata

In this section we will study some technical lemmata showing that for any connected orientable closed surface the mapping class group is generated by Dehn twists. Finally, by using the previous fact we will prove the Wallace-Lickorish theorem.

Let S be an orientable surface.

Lemma 2.11. *Let α and β be simple closed curves in S such that $i(\alpha, \beta) = 1$. Then, $\alpha \sim_c \beta$.*

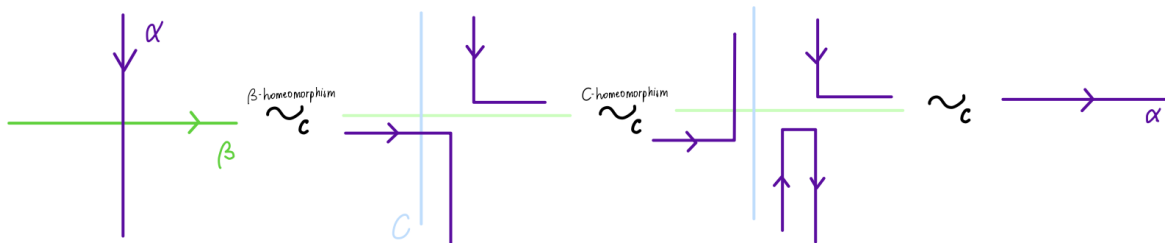

Figure 10

Proof. Consider Figure 10. We apply a β -homeomorphism and then a C -homeomorphism where C is the blue curve (isotopic to α). In this way, we have transformed α into a path isotopic to β . \square

Corollary 2.12. *Let $\gamma_1, \dots, \gamma_m$ be simple closed curves in S such that, for each $i = 1, \dots, m-1$, $i(\gamma_i, \gamma_{i+1}) = 1$. Then $\gamma_1 \sim_c \gamma_m$.*

Lemma 2.13. *Let α and β be simple closed curves in S . Then, there exists a curve $\alpha_* \sim_c \alpha$ in S such that, for some tubular neighbourhood V of β , $\alpha_* \cap (S - V) \subset \alpha \cap (S - V)$ and exactly one of the following statements is true:*

1. α_* does not meet β , i.e. $i(\alpha_*, \beta) = 0$
2. α_* meets β at exactly two points, i.e. $i(\alpha_*, \beta) = 2$, i.e. with zero algebraic intersection (with different directions with respect to a certain orientation).

Proof. We proceed by induction on $n = i(\alpha, \beta)$. If $n = 0$ then one takes $\alpha_* = \alpha$ so that (1) is true. If $n = 1$, by Lemma 2.11 $\alpha \sim_c \beta$ so one can slightly push β to see that β is isotopic to a curve α_* disjoint from α and (1) holds. Then, if $n = 2$ and if there is zero algebraic intersection, one takes $\alpha_* = \alpha$ so that (2) is true. Now, assume that α and β intersects exactly n times and that the lemma holds for simple closed curves that intersect $k < n$ times. After orienting α and β we distinguish two cases. See Figure 11.

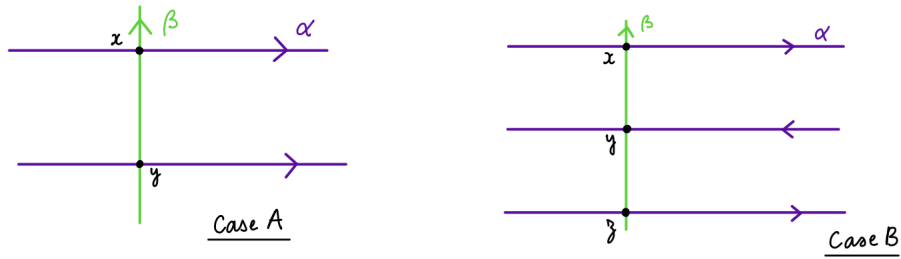

Figure 11

- (A) There are two consecutive intersection points $x, y \in \alpha \cap \beta$ such that at these points α is oriented with the same direction with respect to the orientation of β .
- (B) There are three consecutive intersection points $x, y, z \in \alpha \cap \beta$ such that at these points α is oriented with alternating direction with respect to the orientation of β .

First we study case (A).

Let γ be a curve staying inside a tubular neighbourhood of α outside the diagram and such that it meets α and β each at exactly one point near x and y . See Figure 12. Hence, γ

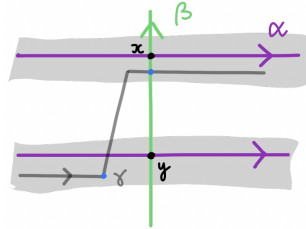

Figure 12

intersects α exactly once so by Lemma 2.11 $\alpha \sim_c \gamma$. Now, γ and β meet less than n times, thus we conclude by applying the induction hypothesis.

Finally, we study case (B). Consider Figure 13. Let C be a curve that intersects α twice,

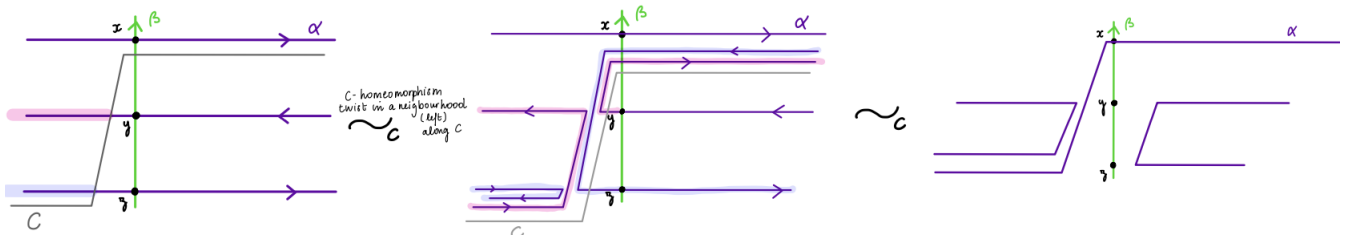

Figure 13

and β once near the three points x, y and z . We take C such that it stays inside a tubular neighbourhood of α outside the diagram. Apply a Dehn twist along C . Then, α is equivalent

under (\sim_c) to a curve that intersects β only $n - 2$ times. We conclude by using the induction hypothesis. \square

Corollary 2.14. *Let $\alpha, \beta_1, \dots, \beta_m$ be simple closed curves in S such that the β_i are pairwise disjoint. Then, there exists a curve α_* such that one of the statements from Lemma 2.13 is satisfied for α_* and each β_i for all $i = 1, \dots, n$.*

Proof. Apply successively Lemma 2.13. \square

Now, let S be a closed connected orientable surface. By the classification theorem of surfaces, S is a connected sum of g tori, i.e. a sphere with handles¹. Consider the situation

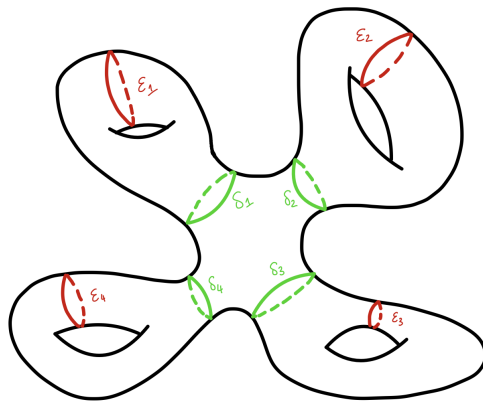

Figure 14

presented in Figure 14. Here we have a closed orientable surface of genus 4 with disjoint simple closed curves δ_i, ϵ_i in each handle.

Lemma 2.15. *Let S be a closed connected orientable surface of genus g with the collection of simple closed curves as shown in Figure 14. Let α be a simple closed curve in S . Then, there exists a curve α_* such that $\alpha \sim_c \alpha_*$ and $\alpha_* \cap \epsilon_i = \emptyset$ for all $i = 1, \dots, g$.*

Proof. First, we apply Corollary 2.14 to $\alpha, \epsilon_1, \dots, \epsilon_g$. Hence, we get a curve $\overline{\alpha}_*$ such that $\alpha \sim_c \overline{\alpha}_*$ and $\overline{\alpha}_*$ either (1) or (2) holds. Then, we apply again Corollary 2.14 to $\overline{\alpha}_*, \delta_1, \dots, \delta_g$. Thus, there exists a curve α_* such that (1) or (2) are satisfied for all δ_i and ϵ_i .

Then, we work separately on each handle S_i of S so that α_* avoids ϵ_i . If (1) is satisfied we are done.

Otherwise we are in situation (2), i.e. α_* meets ϵ_i exactly twice with zero algebraic intersection. Now, if α_* satisfies (1) for δ_i , we are in the following situation.

¹note that here a handle a torus in the connected sum and not an r -handle

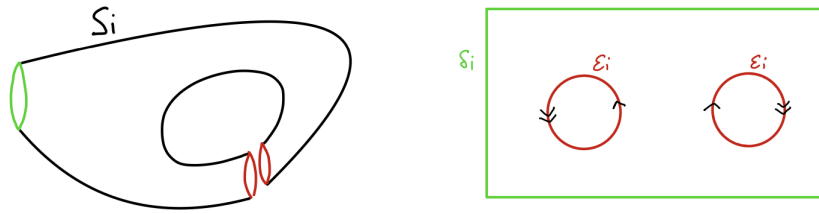

Figure 15

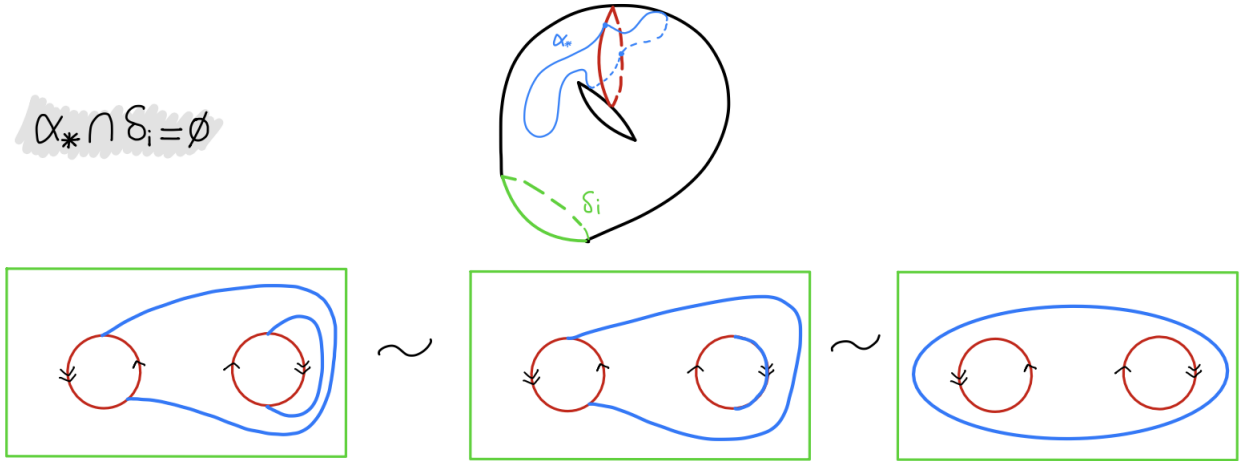

Figure 16

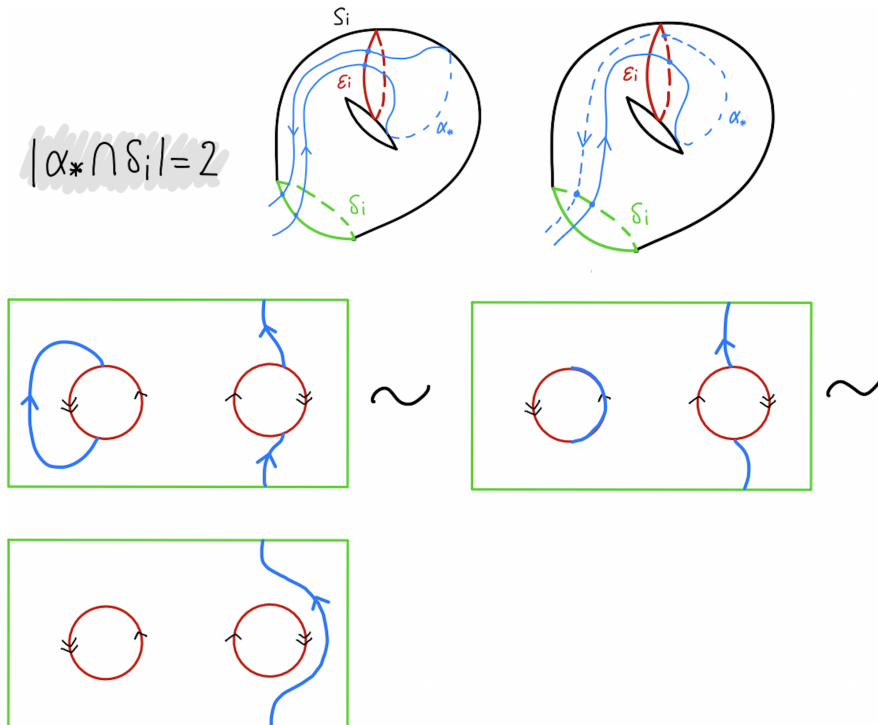

Figure 17

In Figure 15 we see S_i as a rectangle with δ_i as boundary and with identified holes that represents ϵ_i .

Finally, if α_* satisfies (2) for δ_i we are in the following situation. In Figure 17 the curve attached to the left circle is pushed isotopically to lie in ϵ_i . Then, via an isotopy one can push it away from ϵ_i and away from S_i . Note that during the process we left everything fixed outside the handle we are working on.

By repeating the process on each handle of S we obtain a curve isotopic to α_* that avoids the ϵ_i . \square

2.3 Generating the mapping class group

Let S be a closed, connected, orientable surface with genus g . Let α and β be two curves in S , we write $a \equiv b$ if there is an orientation preserving homeomorphism j isotopic to the identity such that $j\alpha = \beta$.

Lemma 2.16. *Let f be an element of the mapping class group of S . Let $\epsilon_1, \dots, \epsilon_g$ be curves as shown in Figure 14. Then, there is a product T of Dehn twists such that $Tf\epsilon_i \equiv \epsilon_i$ for all $i = 1, \dots, g$.*

Proof. We proceed by induction. Take $0 \leq t \leq g$ we show that the following statement $P(t)$ is true.

$P(t)$: there is a product T of Dehn twists such that $Tf\epsilon_i \equiv \epsilon_i$ for all i , $0 \leq i \leq t \leq g$.

The initial step $t = 0$ is true by the Alexander trick (ϵ_0 is the trivial loop). Then, assume that $Tf\epsilon_i \equiv \epsilon_i$ for all i , $0 \leq i \leq t \leq g$. We show that there exists a product of Dehn twist T' such that $T'f\epsilon_i = \epsilon_i$ for all $0 \leq i \leq t + 1 \leq g$.

By Lemma 2.15, $Tf\epsilon_{t+1} \sim_c \alpha_*$, where α_* does not intersects any of the ϵ_i in S . Hence there exists T' a product of Dehn twists such that

$$T'Tf\epsilon_{t+1} \equiv \alpha_* \text{ and } T'Tf\epsilon_i \equiv \epsilon_i \forall i \leq t.$$

The last fact holds because to find T' in the proof of 2.15 we worked on the handle associated to ϵ_{t+1} and during the process we left everything fixed outside the handle we are working on. Since α_* does not intersects any of the ϵ_i in S , it is on the sphere part, i.e. it lives outside the handles. Moreover, observe that ϵ_{t+1} is not homologically trivial so neither is α_* . Hence, α_* divides the sphere into two components which must be connected by one handle at least. See Figure 18. Now, ϵ_{t+1} is not homologically equivalent to the ϵ_i (or a combination of them) so neither is α_* . Recall that α_* lives on the sphere part and is not homologically trivial. Thus, α_* goes through a handle that does not contain any of the ϵ_i for $i \leq t$. The situation is illustrated in Figure 18. Applying Lemma 2.11 successively, we obtain that $\alpha_* \sim_c l \sim_c m \sim_c \epsilon_{t+1}$. Thus, there exists T'' (chosen such that they fix S outside the handle) such that $T''\alpha_* = \epsilon_{t+1}$. Hence by taking $\bar{T} := T''T'T$ we have the result. \square

Lemma 2.17. *Let D_g be a disk from which g disks have been removed. Let f be a homeomorphism on D_g which is the identity on the boundary of D_g . Then, there is a product T of Dehn twists such that jTf is the identity map on D_g , where j is an element isotopic to the identity and leaving D_g fixed on its boundary.*

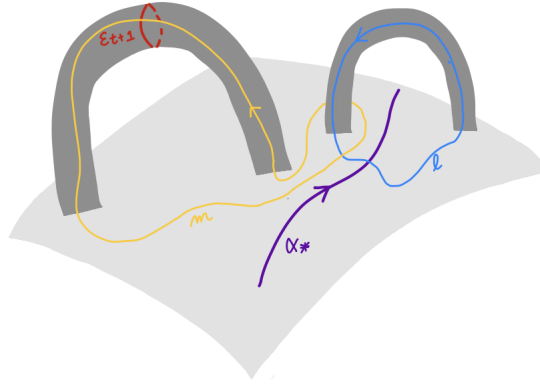

Figure 18

Proof. We show following statement by induction on the number of disks removed:

$P(u)$: Let D_u a disk from which u disks have been removed. Let f be a piecewise linear homeomorphism on D_u which is the identity on the boundary of D_u . Then, there is a product T of Dehn twists such that Tf is the identity map on D_u modulo an element isotopic to the identity and leaving D_u fixed on its boundary.

The case $u = 0$ is given by the Alexander trick. For the induction step, assume we have removed $u + 1$ disks from D_u . Consider f a homeomorphism on D_u which is the identity on the boundary. Consider the following situation. Let α be a curve starting and ending at two distinct components of the boundary. Let A and B be the end points of α . Denote A_2, \dots, A_{n-1} the intersection points of α with $f\alpha$ along α . Since f is the identity on the boundary of D_u , one can assume that f is the identity on α near the ending points. Say f is the identity from A to A_1 and from A_n to B . After orienting α , one distinguishes two cases depending on the orientation of $f\alpha$.

1. The first case is when $f\alpha$ is oriented in the same direction at A_1 and A_2 with respect to the direction of α . See Figure 19. Choose a strategic curve C which behaves like

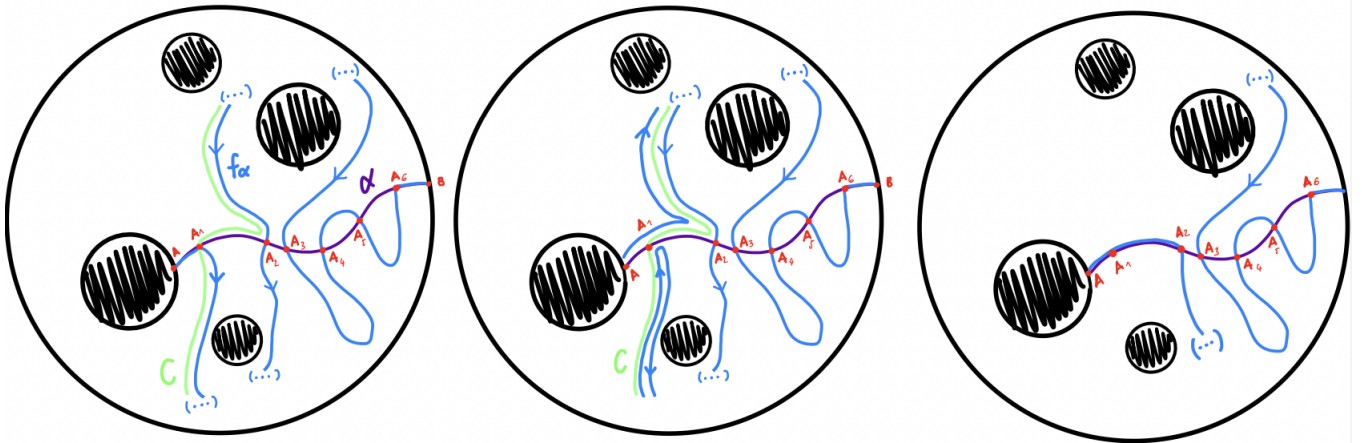

Figure 19

$f\alpha$ between A and A_1 and like α between A_1 and A_2 . Let T_C be the Dehn twist along C and consider $T_C f\alpha$. Modulo an element isotopic to the identity, $T_C f$ is the identity on the segment of α between A and A_2 . Then, $T_C f\alpha$ intersects α fewer times than $f\alpha$ does.

2. The second case is when $f\alpha$ is oriented in different direction at A_1 and A_2 with respect to the direction of α .

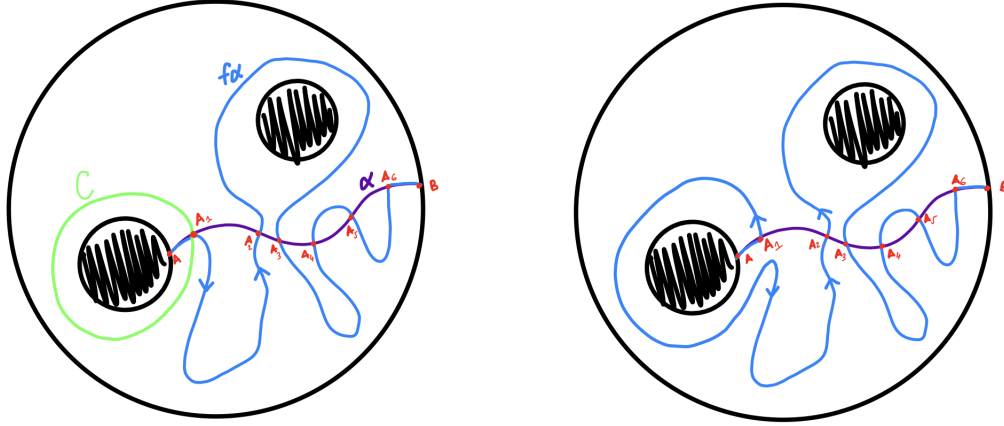

Figure 20

See Figure 20. Again choose a strategic curve C as show in the figure. By applying a Dehn twist along C we come back the the first case.

By repeating the process, we find a product of Dehn twists T such that, modulo an element isotopic to the identity, Tf is the identity on the boundary of D_u and on α . Then, we cut D_u along α and we can apply the induction hypothesis on it to obtain the result. \square

Remark 2.18. In the statement of the lemma, j and T are inversible so this is equivalent to say that f is a product of Dehn twists.

Theorem 2.19. (*Dehn-Lickorish Theorem*) *Let S be a connected closed orientable surface and f an element of the mapping class group of S . Then, f is isotopic to a product of Dehn twists. In other words, the mapping class group of S is generated by Dehn twists.*

Proof. Let S be a closed connected orientable surface of genus g with the collection of simple closed curves as shown in Figure 14. By Lemma 2.16, there is a product T of Dehn twists such that $Tf\epsilon_i \equiv \epsilon_i$ for all $i = 1, \dots, g$. Moreover, there is an a homeomorphism isotopic to the identity j such that $jTf\epsilon_i = \epsilon_i$ for all $i = 1, \dots, g$. Let S_ϵ be the surface S cutting along each ϵ_i 's. Apply Lemma 2.17 to jTf and S_ϵ . Thus, jTf is a composition of Dehn twists on S_ϵ and since it restricts to the identity on the boundary, this is still true when we identify the ϵ_i as well. This gives the result. \square

The Lickorish-Wallace theorem is obtained as an application of Theorem 2.19.

2.4 The Lickorish-Wallace theorem

Theorem 2.20. *Let M be a connected, closed, orientable, combinatorial 3-manifold. Then, M can be obtained by removing a finite number of disjoint solid tori from \mathbb{S}^3 and gluing them back in a different way via homeomorphisms.*

Proof. We consider the Heegard splitting of M into two handlebodies H_1 and H_2 :

$$M = H_1 \cup_f H_2$$

where f is a homeomorphism between the boundaries of H_1 and H_2 . We have seen (Proposition 2.10) that there exists a homeomorphism i between the boundaries of H_1 and H_2 such that:

$$\mathbb{S}^3 \cong H_1 \cup_h H_2.$$

To begin, we explain how to perform a C -homeomorphism on ∂H_1 . Embed $(\mathbb{S}^1 \vee I) \times \mathbb{S}^1$ in H_1 such that $0 \times \mathbb{S}^1$ follows the path C lying in ∂H_1 and $(\mathbb{S}^1 \vee (0, 1]) \times \mathbb{S}^1$ lies in the interior of H_1 with 1 as gluing point in $\mathbb{S}^1 \vee I$.

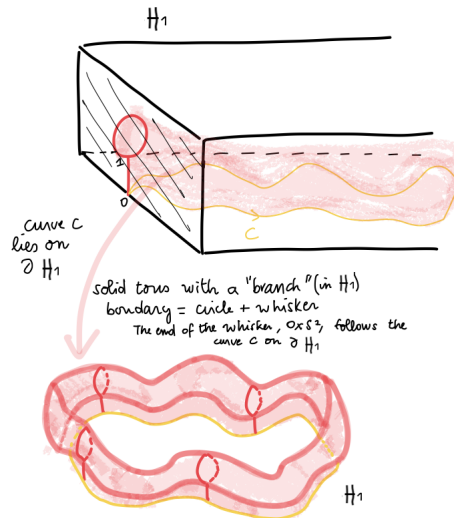

Figure 21

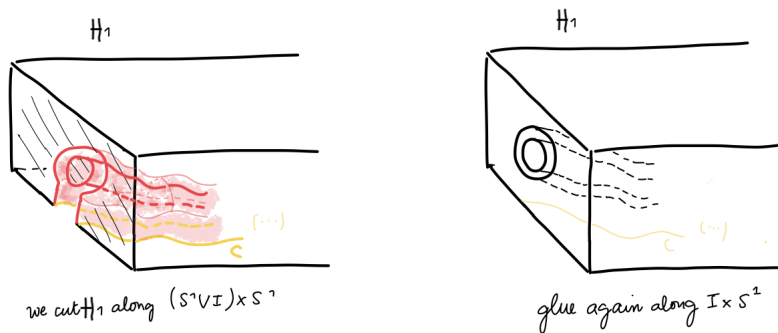

Figure 22

The situation is depicted in Figure 21. Then, cut H_1 along $(\mathbb{S}^1 \vee I) \times \mathbb{S}^1$, twist through 2π along C and glue again along $I \times \mathbb{S}^1$. Hence, we have executed a C -homeomorphism on $H_1 - \{\text{a solid torus}\}$. See Figure 22. To perform a product of C -homeomorphisms, we embed several $(\mathbb{S}^1 \vee I) \times \mathbb{S}^1$ in H_1 distant from each other so that the associated tori that are removed are all disjoint. Then, we proceed as described above.

Now, we show that there exists a finite collection of solid tori in M and \mathbb{S}^3 such that, after removing the collection associated to each space, the resulting spaces are homeomorphic. Since the boundary of a 3-manifold is a 2-manifold, we can apply Theorem 2.19 to $f^{-1}h : \partial H_1 \rightarrow \partial H_1$:

$$f^{-1}h = jT \text{ or equivalently } h = fjT$$

where T is a product of Dehn twists and j is a homeomorphism isotopic to the identity.

Then, $T^{-1}j^{-1}$ corresponds to a product of Dehn twists on ∂H_1 . We use the previous construction, to perform the Dehn twist corresponding to $T^{-1}j^{-1}$, which modified H_1 into $H'_1 := H_1 - \{\text{solid tori}\}$. Gluing H_2 to H'_1 , we obtain:

$$M - \{\text{solid tori}\} = H'_1 \cup_f H_2.$$

Note that in this construction, a point in the boundary of H'_1 is identified with: $x \sim \underbrace{fjT(x)}_{=h}$

$$\begin{array}{ccc} \partial H_1 & \xrightarrow{f} & \partial H_2 \subset H_2 \\ T^{-1}j^{-1} \downarrow & & \downarrow \\ \partial H_1 & & \\ \downarrow & & \\ H'_1 & \xrightarrow{\quad} & \frac{H'_1 \cup H_2}{T^{-1}j^{-1} \sim f} \end{array}$$

Thus we obtain the identification:

$$M - \{\text{solid tori}\} = H'_1 \cup_f H_2 \cong \mathbb{S}^3 - \{\text{solid tori}\}.$$

Then we sew back the disjoint tori that were removed during the process. □

3 Presentation of the mapping class group of a surface

3.1 The mapping class group is finitely generated

In 1964, Lickorish proposed a proof of the fact that the mapping class group of a surface of genus g is finitely generated by Dehn twists along $3g - 1$ non-separating curves [Lic64]. Then, in 1967, he modified his article to give a correct proof.

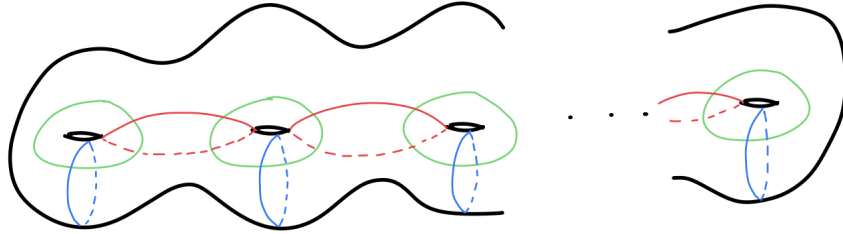

Figure 23

In his paper Lickorish showed that the curves shown in Figure 23 suffice. He slightly modified Lemma 2.13 to improve the main theorem. Here is the statement of the modified lemma:

Lemma (Modified lemma). *Let α and β be simple closed curves in S . Then, there exists a curve $\alpha_* \sim_c \alpha$ in S such that, for some tubular neighbourhood V of β , $\alpha_* \cap (S - V) \subset \alpha \cap (S - V)$ exactly one of the following statement is true:*

1. α_* does not meet β , i.e. $i(\alpha_*, \beta) = 0$
2. α_* meets β at exactly two points, i.e. $i(\alpha_*, \beta) = 2$, with zero algebraic intersection (with different directions with respect to a certain orientation).

Moreover, the twists required in the equivalence $\alpha_ \sim_c \alpha$ can be taken to be along curves c , such that $c \cap \beta$ has fewer points than $\alpha \cap \beta$, and $c \subset \alpha \cup V$.*

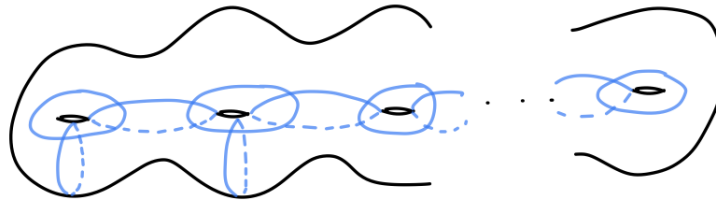

Figure 24

In 1979, Humphries [Hum79] proved that the $2g + 1$ curves in Figure 24 suffice to generate the mapping class group.

Here, our goal is to give the main idea to prove and to motivate the theorem:

Theorem 3.1. *For $g \geq 0$, the mapping class group of a surface of genus g is generated by finitely many Dehn twists along non-separating simple closed curves.*

3.1.1 Basic definitions and background

First, we begin by some definitions and notations. We denote by $S_{g,n} := S_g - \{x_0, \dots, x_n\}$ or S , the surface with empty boundary of genus g with n punctures. Observe that punctures are obtained by removing a closed disk from the surface whereas boundary components are obtained by removing an open disk from the surface. Since we study the mapping class group, sometimes it will be more convenient to think of punctures as marked points because one has

$$\text{Mod}(S - \{x_0, \dots, x_n\}) = \text{Mod}(S, \{x_0\}, \dots, \{x_n\})$$

where the elements of $\text{Mod}(S, x)$ are the elements from $\text{Mod}(S)$ that stabilize the set of punctures.

Given a simple closed curve in a surface S , the surface obtained by cutting S along α is

$$S_\alpha := S - N(\alpha)$$

where $\overline{N(\alpha)} \cong \mathbb{S}^1 \times [-1, 1]$ with core curve $\mathbb{S}^1 \times \{0\} = \alpha$. Hence S_α has two boundary components more than S . A closed curve α is non-separating if the cut surface S_α is connected. The curve is essential if it is not homotopic to a point or a boundary component or a puncture.

Finally, one defines the pure mapping class group of S , $\text{PMod}(S)$ as the subgroup of elements from $\text{Mod}(S)$ that fix the punctures pointwise.

Example 3.2. The mapping class group of the disk, $\text{Mod}(\mathbb{D}^2)$ and the punctured disk $\text{Mod}(\mathbb{D}^2 - x_0)$ by the Alexander trick are trivial. \triangle

Example 3.3. Clearly $\text{Mod}(S_{0,1})$ is trivial. One can modify any homeomorphism of $S_{0,0}$ via isotopy so that it fixes a point $\text{Mod}(S_{0,0})$ is also trivial. Then, we consider the case of $S_{0,3}$. We have an isomorphism,

$$\text{Mod}(S_{0,3}) \longrightarrow \Sigma_3$$

where Σ_3 is the permutation group on three generators. The surjectivity follows from the fact that transpositions corresponds to half twists (see part on braid group). Take a map ϕ that fixes the three marked points x , y and z . To show the injectivity, we need to show that ϕ is isotopic to the identity. Take an arc γ with endpoints x and y , then $\phi(\gamma)$ has the same endpoints and we can assume that γ and $\phi(\gamma)$ have disjoint interior. Cut along $\gamma \cup \phi(\gamma)$ to obtain two disks both with γ and $\phi(\gamma)$ on the boundary and one with the marked point z in its interior.

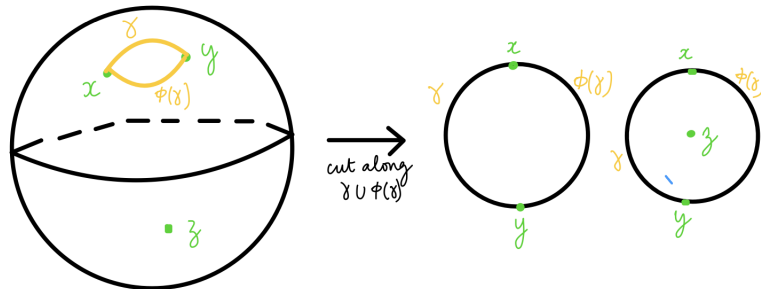

Figure 25

See Figure 25. Since γ and $\phi(\gamma)$ bound a disk in $S_{0,3}$ they are isotopic by Example 3.2 and ϕ is isotopic to an element from the mapping class group ϕ' that fixes γ pointwise. Again, consider $S_{0,3}$ and cut along γ to obtain a disk with one marked point. Then, ϕ' induces a homeomorphism on this disk which is the identity on the boundary. By Example 3.2 ϕ' is isotopic to the identity and thus so is ϕ .

With a similar reasoning one can show that $\text{Mod}(S_{0,2})$ is isomorphic to $\mathbb{Z}/2\mathbb{Z}$. \triangle

Example 3.4. Finally, we consider the torus $S_{1,0}$ denoted by T^2 . We study the following map:

$$\begin{aligned} \sigma : \text{Mod}(T^2) &\longrightarrow \text{Aut}(\text{H}_1(T^2, \mathbb{Z})) \cong \text{Aut}(\mathbb{Z}^2) \cong \text{GL}(2, \mathbb{Z}) \\ f : T^2 &\longrightarrow T^2 \longmapsto f_* : \text{H}_1(T^2, \mathbb{Z}) \longrightarrow \text{H}_1(T^2, \mathbb{Z}) \end{aligned}$$

Let $f \in \text{Mod}(T^2)$ then, $\sigma(f) \in \text{SL}(2, \mathbb{Z})$ because f is invertible and orientation preserving. The surjectivity follows from the fact that $\text{SL}(2, \mathbb{Z})$ acts on \mathbb{R}^2 while preserving \mathbb{Z}^2 . For the injectivity, take an element ϕ in the kernel and α, β two generators of $\pi_1(T^2)$. Then $\phi \circ \alpha$ is homotopic to α . Then ϕ is isotopic to ψ and $\psi|_\alpha = \text{id}$. Cut T^2 along α to get the annulus. Again, $\phi \circ \beta$ is homotopic to α . Then $\psi \circ \beta$ is homotopic to β thus ψ is isotopic to χ and $\chi|_{\alpha \cup \beta} = \text{id}$. Cut along β to obtain a disk then by Example 3.2, χ is isotopic to the identity and so is ϕ . Here we used part 1.2.5 in [FM12] which says that two essential simple closed curves in a surface are isotopic if and only if they are homotopic. \triangle

Take a surface S with a marked point x . Consider the forgetting map:

$$\mathcal{F} : \text{Mod}(S, x) \longrightarrow \text{Mod}(S)$$

which forgets the marked point x . We wonder what is the kernel of \mathcal{F} . Take $f \in \ker(\mathcal{F})$, by definition $\mathcal{F}(f) = \text{id}$, i.e., there exists an isotopy between $\mathcal{F}(f)$ and id . Following the forgetting point during this isotopy we trace a loop in S based at x . Now consider the push map:

$$\begin{aligned} \mathcal{P} : \pi_1(S, x) &\longrightarrow \text{Mod}(S, x) \\ \gamma &\longmapsto [\phi_\gamma] \end{aligned}$$

where $[\phi_\gamma]$ is the map obtained at the end of the isotopy which extends γ viewed as an isotopy of point to the whole surface. Equivalently, one can also define $\mathcal{P}([\gamma]) = T_{\overleftarrow{\gamma}} T_{\overrightarrow{\gamma}}^{-1}$, where $\overleftarrow{\gamma}$ and $\overrightarrow{\gamma}$ are two loops obtained by moving γ slightly to the right and to the left respectively.

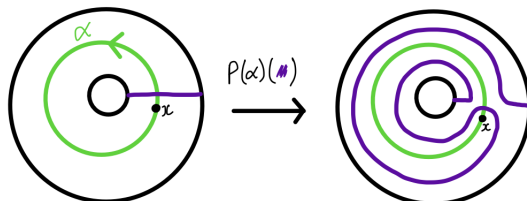

Figure 26

Figure 26 describes the push map. The Birman short exact sequence was given in 1968 by Joan Birman in her thesis [Bir68]. It is given by:

$$\pi_1(S, x) \xrightarrow{\mathcal{P}} \text{Mod}(S, x) \xrightarrow{\mathcal{F}} \text{Mod}(S) \longrightarrow 1.$$

One can also rephrase with $\text{P Mod}(S)$,

$$\pi_1(S, x) \longrightarrow \text{P Mod}(S, x) \longrightarrow \text{P Mod}(S) \longrightarrow 1$$

or

$$\pi_1(S_{g,n}) \longrightarrow \text{P Mod}(S_{g,n+1}) \longrightarrow \text{P Mod}(S_{g,n}) \longrightarrow 1.$$

But where does this short exact sequence come from? Recall that by definition $\text{Mod}(S) = \pi_0(\text{Homeo}^+(S))$ and S is connected. Hence we rewrite:

$$\pi_1(S, x) \longrightarrow \pi_0(\text{Homeo}^+(S, x)) \longrightarrow \pi_0(\text{Homeo}^+(S)) \longrightarrow \pi_0(S)$$

which is the beginning of the long exact sequence in homotopy groups of the fiber bundle

$$\text{Homeo}^+(S, x) \xrightarrow{\mathcal{F}} \text{Homeo}^+(S) \xrightarrow{ev_x} S.$$

Then, a theorem from Hamstrom [HD58] states that if the euler characteristic is such that $\chi(S) < 0$ then the connected component of the identity in $\text{Homeo}^+(S)$ is contractible. Thus $\pi_1(\text{Homeo}^+(S)) = 1$ and \mathcal{P} is injective. Hence, if $\chi(S_{g,n}) < 0$ we have:

$$1 \longrightarrow \pi_1(S_{g,n}) \xrightarrow{\mathcal{P}} \text{P Mod}(S_{g,n+1}) \xrightarrow{\mathcal{F}} \text{P Mod}(S_{g,n}) \longrightarrow 1$$

3.1.2 Sketch of the proof

We move to the proof of Theorem 3.1. First consider the following theorem.

Theorem 3.5. *For $g \geq 1$, $n \geq 0$, $\text{P Mod}(S_{g,n})$ is generated by a finite collection of Dehn twists along non-separating simple closed curves.*

Remark 3.6. We will treat the case $g = 0$ later and we will see that Theorem 3.1 follows directly from the theorem above.

Definition 3.7. Take $S := S_{g,n}$ with $g \geq 1$ and $n \geq 0$. Let $\tilde{\mathcal{N}}(S_{g,n})$ be the one dimensional simplicial complex whose vertices are the isotopy classes of non-separating simple closed curves. Its edges correspond to the curves with geometric intersection number equal to one.

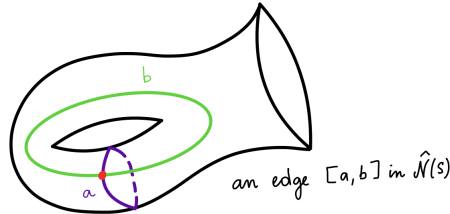

Figure 27

Figure 27 represents an edge in $\tilde{\mathcal{N}}(S_{g,n})$. We will need the two following lemmata to prove Theorem 3.5.

Lemma 3.8. *Let $g \geq 1$ and $n \geq 0$, then $\tilde{\mathcal{N}}(S_{g,n})$ is connected.*

Lemma 3.9. *The stabilizer Γ_α of a non-separating simple closed curve is contained in a subgroup generated by a finite collection of Dehn twists along non-separating closed curves in $S_{g,n}$.*

We will prove these two lemmata in the next section. We start with the proof of Theorem 3.5 and then use it to prove Theorem 3.1.

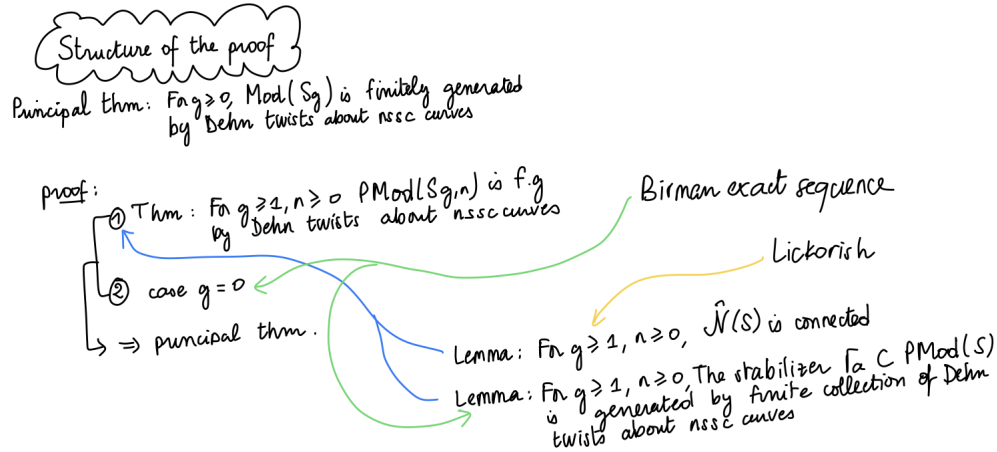

Figure 28

Figure 28 encapsulates the structure of the proof of Theorem 3.1.)

Proof of Theorem 3.1. Assume that Lemmata 3.8 and 3.9 are true. Take $S := S_{g,n}$ with $g \geq 1$ and $n \geq 0$.

We start by studying the action of $\text{PMod}(S)$ on the graph of $\tilde{\mathcal{N}}(S)$. This action is transitive on vertices. To see this, take α and β two non-separating simple closed curves in S and consider the cut surfaces S_α and S_β . By looking at a triangulation or a cellular decomposition of these surfaces, we note that they have the same Euler characteristic (same as S), the same number of boundary components (two more than S) and the same genus (genus of S minus one). By the theorem of classification of surfaces, we obtain a self-homeomorphism of S sending α to β . Similarly, we can show that the action is also transitive on edges. Then the action is also transitive on directed edges. Indeed, one can find a homeomorphism that flips the edge $[\alpha, \beta]$ by taking the element corresponding to $\begin{pmatrix} 0 & -1 \\ 1 & 0 \end{pmatrix}$ in a neighbourhood of $\alpha \cup \beta$ (torus with one hole/puncture, can see this via triangulated surface). Here we use the fact that $\text{Mod}(S_{1,1}) \cong \text{SL}(2, \mathbb{Z})$ (similar proof that Example 3.4, see [FM12]).

Now fix an edge $[\alpha, \beta]$ in $\tilde{\mathcal{N}}(S)$. Take any $f \in \text{PMod}(S)$. By Lemma 3.8 one can find a path (a_i) in $\tilde{\mathcal{N}}(S)$ between α and $f(\alpha)$.

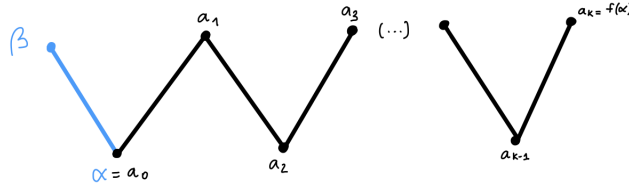

Figure 29

Figure 29 sums up the situation. Again by connectedness, there exists a family (f_i) such that $f_i(\alpha) = a_i$ for each $i = 0, \dots, k$. Let $H := \langle \Gamma_\alpha, T_\beta \rangle$ where Γ_α is the stabilizer of α . We show by induction on i that $f_i \in H$. For $i = 0$, f_0 is the identity which is in H . Then assume $f_i \in H$, we show that so is f_{i+1} . Observe that f_i^{-1} sends $[a_i, f_{i+1}(\alpha)]$ to $[\alpha, f_i^{-1}f_{i+1}(\alpha)]$. Since $\text{P Mod}(S)$ is transitive on edges there exists $\phi \in \text{P Mod}(S)$ such that ϕ sends $[\alpha, f_i^{-1}f_{i+1}(\alpha)]$ to $[\alpha, \beta]$. Thus $\phi \in \Gamma_\alpha$. Then we have:

$$\phi f_i^{-1} f_{i+1}(\alpha) = \beta \Rightarrow T_\beta T_\alpha \phi f_i^{-1} f_{i+1}(\alpha) = T_\beta T_\alpha(\beta) = \alpha$$

where the last equality follows from the fact that α and β intersect exactly once and from Lemma 2.11. Using the induction hypothesis we obtain that $f_{i+1} \in H$. By induction, $f_k = f \in H$ and H is all of $\text{P Mod}(S)$. We conclude the proof of the theorem by applying Lemma 3.9. \square

Now, we treat the case of $\text{P Mod}(S_{0,n})$. For $n \leq 3$ we see in the Example 3.3 that the mapping class group is trivial. The Birman short exact sequence says that:

$$1 \longrightarrow \pi_1(S_{0,3}) \longrightarrow \text{P Mod}(S_{0,4}) \longrightarrow \text{P Mod}(S_{0,3}) \longrightarrow 1$$

Since $\text{P Mod}(S_{0,3})$ is trivial and $\pi_1(S_{0,3}) \cong \mathbb{F}_2$, the free group on two generators, we deduce that $\text{P Mod}(S_{0,4}) \cong \mathbb{F}_2$. The generators of $\pi_1(S_{0,3})$ are represented by non-separating simple loops. They give generators for $\text{P Mod}(S_{0,4})$ which are Dehn twists along non-separating simple loops (with geometric intersection number equal to two). Then, as above we have

$$1 \longrightarrow \pi_1(S_{0,4}) \longrightarrow \text{P Mod}(S_{0,5}) \longrightarrow \text{P Mod}(S_{0,4}) \longrightarrow 1$$

thus $\text{P Mod}(S_{0,5}) \cong \mathbb{F}_3 \rtimes \mathbb{F}_2$. And this yields $\text{P Mod}(S_{0,n})$ for all n , inductively.

Finally, observe the following short exact sequence:

$$1 \longrightarrow \text{P Mod}(S_{g,n}) \longrightarrow \text{Mod}(S_{g,n}) \longrightarrow \Sigma_n \longrightarrow 1$$

taking $n = 1$ we have $\text{P Mod}(S_{g,1}) \cong \text{Mod}(S_{g,1})$, the case $n = 0$ gives Theorem 3.1.

Remark 3.10. The theorem does not hold for multiple punctures, no composition of Dehn twists can permute the punctures.

Remark 3.11. In fact we already observed the case of $\text{P Mod}(S_{0,n})$ in the proof of Property 1.13.

The next step is to determine explicitly the generators.

Theorem 3.12 (Lickorish, 1967). *For $g \geq 1$, the Dehn twists along isotopy classes of $a_1, \dots, a_g, b_1, \dots, b_g, c_1, \dots, c_{g-1}$ (Figure 23) generate the mapping class group of S_g (a_i 's in blue, b_i 's in green and c_i 's in red).*

3.1.3 Toolbox for the proof

We give a sketch of the proof of the two lemmata we assumed to prove Theorem 3.5.

Sketch of proof of Lemma 3.8. For $S_{1,n}$, we need to proceed directly by induction on n with base case $S_{1,1}$ and $S_{1,0}$. We give an idea of the proof for $g \geq 2$ and $n \geq 0$.

First we study the graph $X(S)$ whose vertices are the isotopy classes of essential simple closed curves in S . The edges correspond to the curves that do not intersect or intersect exactly once. This graph is connected. Indeed, take a and b two essential simple closed curves that intersect many times. Next, replace a by a curve adjacent that intersects b fewer times than a does (proof of Lemma 2.13).

Then, take a path $(a_i)_i$ in $X(S)$. Fix the end-points, by induction on n we show that the interior of the path can be reduced consisting only in non-separating simple closed curves. For the base case, let $g \geq 2$ and $n \leq 1$ and consider a_i . If it is non-separating we are done. If it is not, consider $S - a_i$, which has two components S' and S'' with positive genus. If a_{i-1} and a_{i+1} lie in different components then they are disjoint, so we delete a_i . Otherwise, they both lie in S' so we replace a_i by the isotopy class of a non-separating curve in S'' . For the induction step, we proceed as above. Note that if a_{i-1} and a_{i+1} lie in the same component and the other component has genus 0 we can apply the induction hypothesis since we have less punctures. The connectivity of $\tilde{\mathcal{N}}(S_{g,n})$ follows from the fact that given two disjoint non-separating simple closed curves one can find an (essential) non-separating simple closed curve that intersects each of them exactly once. \square

Sketch of proof of Lemma 3.9. Note that $\Gamma_a = \text{PMod}(S, a)$. The idea is to proceed by double induction on g and n . We start by the induction on $g \geq 1$. The base case is for the $S_{1,0}, \dots, S_{1,n}$, in fact we show that if the lemma holds for $S_{g,n}$ it also holds for $S_{g,n+1}$. Let's start by the inductive step, assume that the Lemma is true for $S_{g-1,n}$. We can generate Γ_a from $\text{PMod}(S_{g,n-1})$ by adding T_a and an element that reverse the sides of a . This follows from the two following short exact sequences (see Property 3.20 in [FM12]):

$$1 \longrightarrow \text{PMod}(S_{g,n}, \vec{a}) \longrightarrow \text{PMod}(S_{g,n}, a) \longrightarrow \mathbb{Z}/2\mathbb{Z} \longrightarrow 1 \quad (\star)$$

and

$$1 \longrightarrow \langle T_a \rangle \longrightarrow \text{PMod}(S_{g,n}, \vec{a}) \longrightarrow \text{PMod}(S_{g,n} - a) \longrightarrow 1$$

where $\text{PMod}(S_{g,n}, \vec{a})$ are the elements of $\text{PMod}(S_{g,n}, a)$ that preserve the orientation of a and $S_{g,n} - a$ is a surface $S_{g-1,n+2}$. We conclude using the induction hypothesis and the base case. Now, we show the base case. Assume that the lemma holds for $S_{g,n}$ and consider the

following diagram:

$$\begin{array}{ccccccc}
& & & 1 & & & 1 \\
& & & \uparrow & & & \uparrow \\
1 & \longrightarrow & \pi_1(S_{g,n} - a) & \longrightarrow & \text{P Mod}(S_{g,n+1} - a) & \twoheadrightarrow & \text{P Mod}(S_{g,n} - a) & \longrightarrow & 1 \\
& & & \uparrow & & & \uparrow & & \\
1 & \longrightarrow & \ker(\rho) & \longrightarrow & \text{P Mod}(S_{g,n+1}, \vec{a}) & \xrightarrow{\rho} & \text{P Mod}(S_{g,n}, \vec{a}) & \longrightarrow & 1 \\
& & & \uparrow & & & \uparrow & & \\
& & & \langle T_a \rangle & \xlongequal{\quad} & \langle T_a \rangle & & & \\
& & & \uparrow & & & \uparrow & & \\
& & & 1 & & & 1 & &
\end{array}$$

By a diagram chase, ρ is surjective. The first horizontal short exact sequence is given by the Birman sequence. By the induction hypothesis, $\text{P Mod}(S_{g,n}, \vec{a})$ is finitely generated by a finite collection of Dehn twists along non-separating closed curves. Hence so is $\text{P Mod}(S_{g,n} - a)$ by surjectivity of the second vertical map in the square. We know that $\pi_1(S_{g,n} - a)$ is also finitely generated by non-separating simple loops. Thus, $\text{P Mod}(S_{g,n+1} - a)$ is finitely generated by a finite collection of Dehn twists along non-separating closed curves (given by the lifts of the generators of $\text{P Mod}(S_{g,n} - a)$ and the images of the generators of $\pi_1(S_{g,n} - a)$). So $\text{P Mod}(S_{g,n+1}, \vec{a})$ is finitely generated by a finite collection of Dehn twists along non-separating closed curves and so is $\text{P Mod}(S_{g,n+1}, a)$ by the short exact sequence (\star) . \square

3.2 The mapping class group is finitely presented

We have found that the mapping class group of a surface is finitely generated. Now, what about relations? Information about the relations of a group G is encapsulated in the first and second homology groups of G , which are the homology groups of any $\text{K}(G, 1)$. Indeed, the first homology group of a group G is the abelianization of G . The link between the second homology group and the relations of the group is given by the Hopf formula but we will not see it here. In this section, we start by listing some important relations that appear in the mapping class group of a surface. Then, we compute the first homology group of the mapping class group of $S_{g,n}$ to study its abelianization. Finally, we show that the mapping class group of $S_{g,n}$ is finitely presented, this is equivalent to show that $\text{K}(G, 1)$ has a finite 2-skeleton. Along the way, we will meet an interesting construction, the arc complex, a close cousin to the complex of curves at which we will look at closely in the next section.

Remark 3.13. Recall that for X a topological space, $\text{H}_1(X, \mathbb{Z}) \cong (\pi_1(X))_{\text{ab}}$. Hence for a group G , $\text{H}_1(G, \mathbb{Z}) := \text{H}_1(\text{K}(G, 1), \mathbb{Z}) \cong (\pi_1(\text{K}(G, 1)))_{\text{ab}} \cong (\pi_1(G))_{\text{ab}}$.

3.2.1 Relations

Here we point out some interesting relations.

Example 3.14 (Disjointness relation). Let a, b be isotopy classes of simple closed curves in a surface S such that $i(a, b) = 0$, then we have

$$T_a T_b = T_b T_a.$$

△

Example 3.15 (Braid relations). Let a, b be isotopy classes of simple closed curves such that $i(a, b) = 1$. Then,

$$T_a T_b T_a = T_b T_a T_b.$$

Indeed, this relation is equivalent to $(T_a T_b) T_a (T_a T_b)^{-1} = T_b$. By observing that for $\phi \in \text{Mod}(S)$, $\phi T_a \phi^{-1} = T_{\phi(a)}$ we deduce that this is equivalent to $T_{T_a T_b(a)} = T_b$. Since $T_c = T_d$ if and only if $c = d$, we conclude by considering Figure 10 which tells us that $T_a T_b(a) = b$, where a is the yellow/green curve and b is the red one. △

Example 3.16 (k -chain relation). Let $k \geq 0$ and c_1, \dots, c_k a sequence of simple closed curves in a surface S such that $i(c_i, c_{i+1}) = 1$ for all i and $i(c_i, c_j) = 0$ for all non consecutive i and j . Let V be a closed regular neighbourhood of $c_1 \cup \dots \cup c_k$. Then we have:

- For k even, $(T_{c_1} \dots T_{c_k})^{2k+2} = T_\delta$ where $\delta := \partial V$.
- For k odd, $(T_{c_1} \dots T_{c_k})^{k+1} = T_{\delta_1} T_{\delta_2}$ where $\delta_1 \cup \delta_2 := \partial V$

For instance, let S be a surface and a, b be two non separating simple closed curves in S that intersect exactly once. A neighbourhood of $a \cup b$ is a torus with one hole. We have already seen that one can identify the mapping class group of a one-holed torus with $\text{SL}(2, \mathbb{Z})$. We send T_a and T_b to the generators of $\text{SL}(2, \mathbb{Z})$, $\begin{pmatrix} 0 & -1 \\ 1 & 0 \end{pmatrix}$ and $\begin{pmatrix} 1 & 1 \\ 0 & 1 \end{pmatrix}$. Then, one can see that $T_a T_b$ has order 6, hence $T_a T_b = T_d$ where d is the boundary of the regular neighbourhood of $a \cup b$. △

Example 3.17 (Lantern relation). Let x, y, z , be simple closed curves in a surface S with boundary components a, b, c, d . See Figure 30. Then, we have the relation:

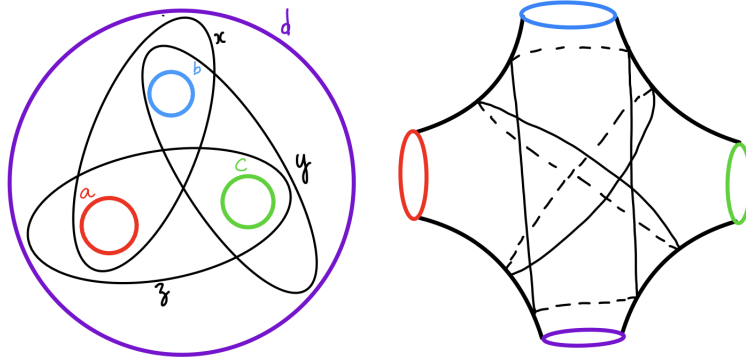

Figure 30

$$T_x T_y T_z = T_a T_b T_c T_d.$$

△

Example 3.18 (Hyperelliptic relation). Let $k \geq 0$ and c_1, \dots, c_{2g+1} a sequence of simple closed curves in a surface S_g such that $i(c_i, c_{i+1}) = 1$ for all i and $i(c_i, c_j) = 0$ for all non consecutive

i and j . Let V be a closed regular neighbourhood of $c_1 \cup \dots \cup c_k$. Then, we have the following relations

$$(T_{c_{2g+1}} \dots T_{c_1} T_{c_1} \dots T_{c_{2g+1}})^2 = 1$$

$$[T_{c_{2g+1}} \dots T_{c_1} T_{c_1} \dots T_{c_{2g+1}}, T_{c_{2g+1}}] = 1.$$

△

Theorem 3.19. *For $g \geq 3$, the group $H_1(\text{Mod}(S_g), \mathbb{Z})$ is trivial.*

Proof. Let S_g be a surface with genus $g \geq 3$. Observe that the Dehn twists along non separating simple closed curves are all conjugates to each other since for $\phi \in \text{Mod}(S)$, $\phi T_a \phi^{-1} = T_{\phi(a)}$. Hence,

$$\Psi : \text{Mod}(S) \longrightarrow H_1(\text{Mod}(S), \mathbb{Z}) \cong \text{Mod}(S)_{\text{ab}}$$

maps the generators of $\text{Mod}(S)$ to the same element in $H_1(\text{Mod}(S), \mathbb{Z})$ since $\text{Mod}(S)$ is generated by Dehn twists. So $H_1(\text{Mod}(S), \mathbb{Z})$ is generated by an element h . We show that h is trivial. Since $g \geq 3$ one can embed into S a surface S_0^4 with genus 0 and boundary components a, b, c, d which are different and essential. See Figure 31. Let x, y, z , be simple closed curves

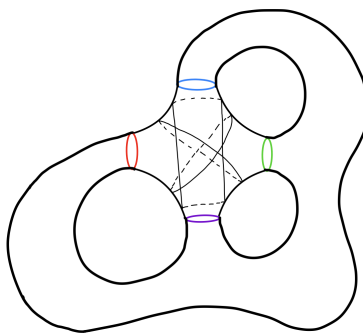

Figure 31

in the embedded surface. By looking at the image of the lantern relation under Ψ we obtain $h^4 = h^3$ so h is trivial. □

McCool gave in 1975 a first algebraic proof for the existence of a finite presentation for the mapping class group of higher genus surfaces. Then in 1980, Hatcher and Thurston gave an algorithm expliciting a finite presentation. Finally, in 1983 (and corrected in 1984 with Birman) Wajnryb described explicitly a presentation known as *the standard presentation*:

$$\left\langle \text{Humphries generators} \left| \begin{array}{l} \text{Disjointness, Braid, 3-chain} \\ \text{Lantern, (and Hyperelliptic if } S \text{ is closed)} \end{array} \right. \right\rangle$$

for surfaces with genus $g \geq 3$. Later Gervais gave another presentation using the star relation, which further simplified the presentation. For $g = 0$, the presentation is the same as the presentation of the braid group. For $g = 1$ and at most one puncture, we already identified the mapping class group with $\text{SL}(2, \mathbb{Z})$. For $g = 1$ and more than one puncture we need to work a little more with the lantern relation, see Theorem 5.1 in [Kor03]. For $g = 2$, we don't have all the tools (in particular the Birman-Hilden theorem), a presentation is given in Section 5.1 and in Chapter 9 in [FM12].

3.2.2 Proof of finite presentability

The strategy, pointed out by Andrew Putman and also presented in [FM12], is to prove that the arc complex is contractible and to build a $K(\text{Mod}(S), 1)$ with finite 2-skeleton by using the action of $\text{Mod}(S)$ on the arc complex.

Let S be a surface with non empty boundary or with at least one marked point.

Definition 3.20. A *flag complex* is an abstract simplicial complex where $k + 1$ vertices span a k -simplex if and only if they are pairwise connected by edges.

Definition 3.21. A *proper arc* in S is a curve $\alpha : [0, 1] \rightarrow S$ such that its endpoints are in the set of marked points or in the boundary of S . A closed curve is *essential* if it is not homotopic to a point, a puncture, or a boundary component.

Definition 3.22. The *arc complex* of S , denoted $\mathcal{A}(S)$ is the flag complex whose vertices are isotopy classes of simple essential proper arcs. The edges of the arc complex correspond to vertices that admits disjoint representatives.

Proposition 3.23. $\mathcal{A}(S)$ is contractible

Sketch of proof. Take a vertex $v \in \mathcal{A}(S)$. The *simplicial star* of v is the contractible space given by the union of closed simplices containing v . The strategy is to construct a deformation retract of $\mathcal{A}(S)$ onto the simplicial star of v . Since simplicial stars are contractible, the result will follow.

Let p be an arbitrary point in the simplex spanned by $v_1, \dots, v_k \in \mathcal{A}(S)$. We write $p = \sum c_i v_i$, where $\sum c_i = 1$ and $c_i > 0$. Let v_i and v be the representatives in S of the vertices v_i and v in $\mathcal{A}(S)$. We can realize p by thickening each v_i in S to a band with width c_i . Hence, the widened v_i intersect v in $i(v, v_i)$ intervals of width c_i . Via an isotopy one can slightly modify all the v_i 's to glue these intervals into one interval with width $\theta := \sum c_i i(v, v_i)$. We define the flow as follows, at time t , we push a part of width $t\theta$ of the big band around v towards a chosen direction along v .

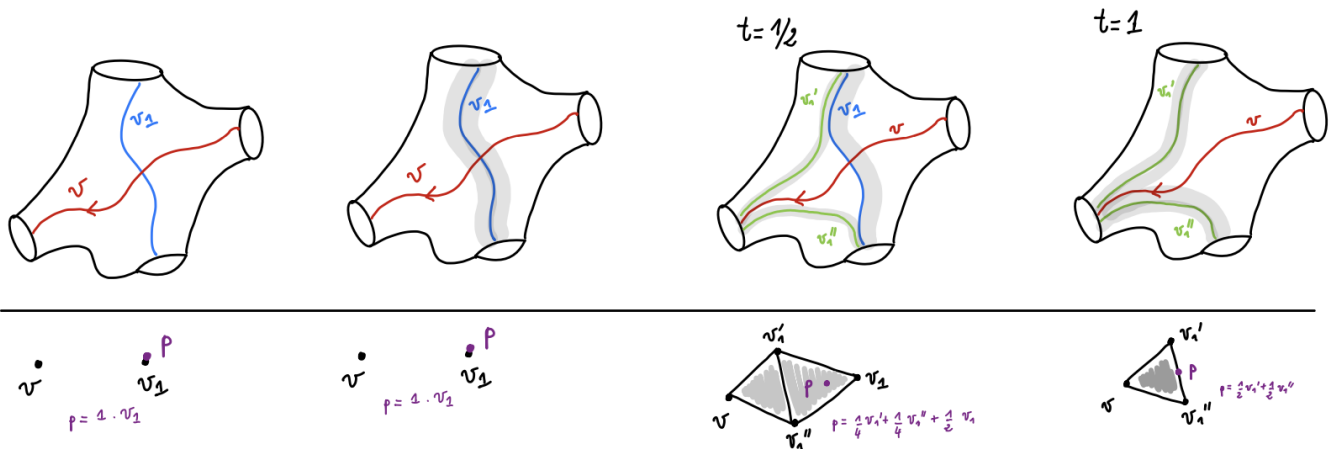

Figure 32: Example of the construction of the flow with two curves

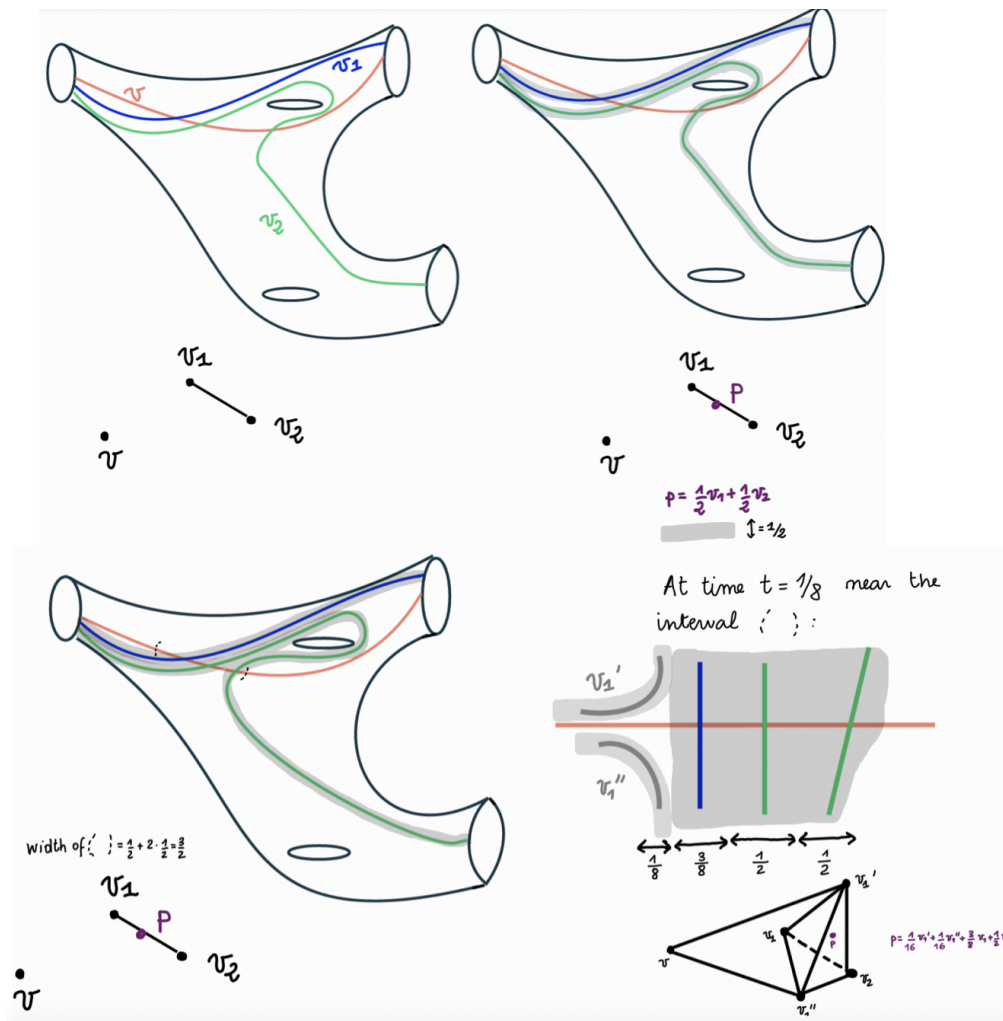

Figure 33: Example of the construction of the flow with three curves

See Figures 32 and 33. This is continuous and well-defined. The point p is slightly pushed in the direction of the star complex. The part of the band that is sent along v are disjoint from v and the v_i 's. In this way, p has new coordinates in terms of representatives of these new disjoint arcs. The point p lies in the new simplex in $\mathcal{A}(S)$ created by adding the edges corresponding to these new arcs. Finally, at time $t = 1$, all the arcs in the band are disjoint and p lies in the simplicial star of v . For more details see [Hat91]. \square

Proposition 3.24. *Let Γ be a group acting cellularly on a contractible CW complex X without rotation. If*

- X/Γ is finite,
- each vertex stabilizer is finitely presented,
- each edge stabilizer is finitely generated.

Then, Γ is finitely presented.

Proof. Presented in class.

□

Theorem 3.25. *Let S be a compact surface with finitely many marked point. Then $\text{Mod}(S)$ is finitely presented.*

Proof. Presented in class.

□

4 The Complex of curves

The mapping class group of a surface is not hyperbolic but it admits an action on the curve complex, which is a hyperbolic space. The latter is close to the arc complex $\mathcal{A}(S)$ that we have seen in the proof of finite presentability. Such an action allows us to find nice results about the geometry of the mapping class group. See the series of papers from Ursula Hamenstaedt to go further. Here we give a sketch of the proof that the curve complex is a hyperbolic space by following [HPW13]. The details of the proof were presented in class.

The curve complex, denoted $\mathcal{C}(S)$, is the complex whose underlying graph has essential simple closed curves as vertices and whose edges correspond to pairs of disjoint curves. The arc and curve complex, denoted $\mathcal{AC}(S)$, is a combination of the arc complex and the curve complex.

First, we prove that the arc complex is 7-hyperbolic. A geodesic space Γ is *k-hyperbolic* if, for every geodesic triangle, there is a vertex at distance $\leq k$ from each of the three sides.

The main tool in the proof is the notion of unicorn path. Consider the arc complex. To get a unicorn path you need two arcs in minimal position a and b . Give a direction and endpoints to these arcs. Travel along a until you meet an intersection point with b . Then, follow b from this intersection point to the starting point of b . Note that you don't necessarily obtain an arc (you might have self-intersections) but if you get one then it is called a unicorn arc. You can order unicorn arcs between two arcs to get a unicorn path. The family of unicorn paths have nice properties allowing us to prove the hyperbolicity of the arc complex.

Finally, one constructs a 2-Lipschitz retraction from $\mathcal{AC}(S)$ to $\mathcal{C}(S)$. Hence, we can observe that a geodesic in the curve complex is a 2-quasigeodesic in the arc complex. This means that one can control the distance in $\mathcal{C}(S)$ with the distance from $\mathcal{AC}(S)$. Thus, to obtain 17-hyperbolicity of the curve complex one can view a geodesic triangle from $\mathcal{C}(S)$ in $\mathcal{AC}(S)$. Then, approximating this triangle with an "arc-geodesic" triangle and using 7-hyperbolicity of $\mathcal{A}(S)$ with the previous retraction, you get 17-hyperbolicity of $\mathcal{C}(S)$.

References

- [Bir68] J. S. Birman. *Braid groups and their relationship to mapping class groups*. Ed. by Roger Fenn. 1968, pp. 213–238.
- [Bry01] John L. Bryant. “Piecewise Linear Topology”. In: 2001.
- [Chr08] Vladimir Turaev Christian Kassel. *Braid groups*. Springer, 2008.
- [FM12] B. Farb and D Margalit. *A Primer on mapping class groups*. Princeton University Press, 2012.
- [Hat91] Allen Hatcher. *Triangulations of surfaces*. 1991. URL: <http://pi.math.cornell.edu/~hatcher/Papers/TriangSurf.pdf>.
- [HD58] Mary-Elizabeth Hamstrom and Eldon Dyer. “Regular mappings and the space of homeomorphisms on a $2n$ -manifold”. *Duke Mathematical Journal* 25 (1958), pp. 521–531.
- [HPW13] Sebastian Hensel, Piotr Przytycki, and Richard C. H. Webb. *Slim unicorns and uniform hyperbolicity for arc graphs and curve graphs*. 2013. URL: <https://arxiv.org/abs/1301.5577>.
- [Hum79] Stephen P. Humphries. *Generators for the mapping class group*. Ed. by Roger Fenn. Springer Berlin Heidelberg, 1979, pp. 44–47. ISBN: 978-3-540-35186-3.
- [Kor03] Mustafa Korkmaz. *Low-dimensional homology groups of mapping class groups: a survey*. 2003. URL: <https://arxiv.org/abs/math/0307111>.
- [Lic62] W. B. Lickorish. “A Representation of Orientable Combinatorial 3-Manifolds.” *Annals of Mathematics*, vol. 76, no. 3, 1962, pp. 531–540. JSTOR (1962). URL: <https://doi.org/10.2307/1970373>.
- [Lic64] W. B. R. Lickorish. “A finite set of generators for the homeotopy group of a 2-manifold”. *Proceedings of the Cambridge Philosophical Society* 60.4 (Jan. 1964), p. 769. DOI: 10.1017/S030500410003824X.
- [Lic97] W.B Raymond Lickorish. *An introduction to knot theory*. Springer, 1997.
- [MM99] Howard A. Masur and Yair N. Minsky. “Geometry of the complex of curves I: Hyperbolicity” (Oct. 1999).