

**SUPERSYMMETRIC EUCLIDEAN FIELD THEORIES  
AND GENERALIZED COHOMOLOGY**

STEPHAN STOLZ (NOTES BY ARLO CAINE)

ABSTRACT. Lectures notes from a topics course on the definition of supersymmetric Euclidean field theories and their relation to generalized cohomology. Notre Dame. Spring 2009

## CONTENTS

1. Generalized Cohomology Theories	3
2. Examples: $H$ , $K$ , and $TMF$	4
3. Coefficients of $TMF$	7
4. Compactly Supported GCT's	10
5. The push-forward map, bordism groups, and invariants	13
6. Realizations of the $\alpha$ -invariant	17
Digression on the Dirac Operator	17
Digression on Curvature	18
7. A Motivating Conjecture	20
8. Preliminary Definition of Field Theories	22
9. Examples	24
10. Partition Functions and Physics Motivations	26
11. The $1 1$ -case.	29
12. The $1 1$ -nonlinear sigma model and $KO$	31
13. The $\hat{A}$ -genus as a partition function	34
14. Functions transforming as modular forms	36
15. Functions transforming as modular forms: Revisited	37
16. Vector bundles over categories	40
17. Weierstrass curves and the moduli stack $\overline{\mathcal{M}}$	43
18. Integral modular forms as sections over $\overline{\mathcal{M}}$	46
Topological Modular Forms	47
19. The road to $tmf$ : spectra and GCT's	47
20. $tmf$ and elliptic cohomology	50
21. Monoidal categories and 2-categories	53
22. Internal categories	57
23. $d$ -RB as a category internal to $\text{SymCat}$	60
Definition of $d$ -RB	60
24. The definition of field theories	63
Definition of $TV^{fam}$	64
Definition of $d$ -RB $^{fam}$	64
25. Supermanifolds	65
26. Generalized Supermanifolds and the Super Euclidean group	68
The super Euclidean group of $\mathbb{R}^{d \delta}$	70
27. Super Euclidean Manifolds	71
28. EFT's of dimensions 0 and $0 1$	73
29. The partition function of a $2 1$ -EFT	76
References	78

## 1. GENERALIZED COHOMOLOGY THEORIES

**Definition 1.1.** A *generalized cohomology theory (reduced)* (GCT) is a collection of functors  $\tilde{h}^n: \text{Top}^{\text{op}} \rightarrow \text{Ab}$ ,  $n \in \mathbb{Z}$ , from a category of topological spaces<sup>1</sup> to the category of abelian groups satisfying the Eilenberg-Steenrod axioms:

- i) (Homotopy Invariance) If two morphisms  $f, g: X \rightarrow Y$  are homotopic, then  $f^* = g^*: \tilde{h}^n(Y) \rightarrow \tilde{h}^n(X)$ .
- ii) (LES for Cofibration) For each cofibration<sup>2</sup>  $i: A \hookrightarrow X$  there is a long exact sequence (LES)

$$(1.1) \quad \cdots \longleftarrow \tilde{h}^n(A) \xleftarrow{i^*} \tilde{h}^n(X) \xleftarrow{p^*} \tilde{h}^n(X/A) \xleftarrow{\delta} \tilde{h}^{n-1}(A) \longleftarrow \cdots$$

where the connecting homomorphisms  $\delta$  are natural in  $X$ .

If  $\tilde{h}$  is a generalized reduced cohomology theory then we obtain an unreduced generalized cohomology theory by setting  $h^n(X) = \tilde{h}^n(X \amalg \text{pt})$  for each  $n$ . For reduced theories,  $\tilde{h}^n(\text{pt}) = 0$  for each  $n$ , but for an unreduced theory  $h^n(\text{pt}) = \tilde{h}^n(S^0)$  may be non-zero and these groups are referred to as the *coefficients* of the theory.

The Eilenberg-Steenrod axioms for ordinary cohomology include the following third axiom:

- iii) (Dimension Axiom)  $h^n(\text{pt}) = \tilde{h}^n(S^0) = 0$  for  $n \neq 0$ .

Without it, we are considering a generalized cohomology theory.

As a simple consequence of the axioms, we can deduce the suspension isomorphism. Consider the inclusion  $A \hookrightarrow CA = A \times [0, 1]/(a, 0) \sim (a', 0)$  of a topological space  $A$  into the cone over  $A$ . This mapping is a cofibration and  $CA/A$  is the suspension of  $A$ , denoted  $\Sigma A$ . Since  $CA$  is contractible,  $\tilde{h}^n(A) = \tilde{h}^n(\text{pt}) = 0$  for all  $n$  and thus  $\delta: \tilde{h}^{n-1}(A) \rightarrow \tilde{h}^n(\Sigma A)$  is an isomorphism for each  $n$ .

*Example 1.2.* Some GCT's:

- i) The ordinary cohomology of  $X$ .
- ii) If  $X$  is a smooth manifold, then  $H_{DR}^n(X) \simeq H^n(X, \mathbb{R})$  by de Rham's theorem. Considering manifolds is not too terrible a restriction since any finite CW complex is homotopy equivalent to a manifold with boundary. Sure there are pathological spaces out there, but most topologists are interested in reasonable spaces.
- iii) K-Theory of a compact manifold  $X$ . The group  $K^0(X)$  is easy to describe, but  $K^n(X)$  for  $n \neq 0$  is more complicated. The set  $\text{Vect}(X)$  of isomorphism classes of  $\mathbb{C}$ -vector bundles over  $X$  forms a commutative monoid with respect to the Whitney sum. The Grothendieck enveloping group of this monoid is  $K^0(X)$ . Using the suspension isomorphism and Bott periodicity, one defines  $K^n(X)$  for  $n \neq 0$  producing a GCT. The coefficient groups are  $K^n(\text{pt}) = 0$  if  $n$  is odd and  $K^n(\text{pt}) = \mathbb{Z}$  if  $n$  is even.

<sup>1</sup>specifying that  $\tilde{h}^n$  is a functor from  $\text{Top}^{\text{op}} \rightarrow \text{Ab}$  is a fancy of saying that it is a contravariant functor  $\text{Top} \rightarrow \text{Ab}$ . Here  $\text{Top}^{\text{op}}$  denotes the opposite category of  $\text{Top}$  whose objects are the same, but whose arrows are reversed.

<sup>2</sup>A map  $i: A \rightarrow X$  is a cofibration iff for each  $f \in \text{Mor}(X, Y)$  and  $g \in \text{Mor}(A, Y)$  such that  $f|_A$  is homotopic to  $g$  there exists an extension  $\tilde{g}: X \rightarrow Y$  of  $g$  and an extension of the homotopy  $f|_A \sim g$  to a homotopy  $f \sim \tilde{g}$ .

There is a correspondence in algebraic topology between generalized cohomology theories and homotopy spectra. Later in the course, we will discuss this correspondence in more detail.

**Definition 1.3.** A *modular form* (with respect to  $\mathrm{SL}(2, \mathbb{Z})$ ) of weight  $k$  is a map  $f: \mathfrak{h} = \{\tau \in \mathbb{C} \mid \mathrm{Im}(\tau) > 0\} \rightarrow \mathbb{C}$  such that

- i)  $f(A\tau) = (c\tau + d)^k f(\tau)$  where

$$A\tau = \frac{a\tau + b}{c\tau + d} \text{ for each } A = \begin{pmatrix} a & b \\ c & d \end{pmatrix} \in \mathrm{SL}(2, \mathbb{Z});$$

- ii)  $f$  is holomorphic on  $\mathfrak{h}$ .  
 iii)  $f$  is holomorphic at  $i\infty$ .

The third requirement on  $f$  may need some explanation. Since  $f$  is periodic with respect to  $\mathbb{Z}$  by i), it can be viewed as a function on the cylinder  $\mathfrak{h}/\mathbb{Z}$ . The map  $\tau \mapsto q = e^{2\pi i\tau}$  is a bi-holomorphism of  $\mathfrak{h}/\mathbb{Z}$  with the punctured unit disk sending  $\mathbb{R}/\mathbb{Z}$  to the unit circle and  $i\infty$  to the origin. So  $f$  can also be viewed as a holomorphic function in the punctured unit disk and thus has a Laurent expansion in  $q$ . If this expansion is, in fact, a Taylor series about 0, then we say that  $f$  is holomorphic at  $i\infty$ .

Hopkins and Miller introduced a spectrum (and therefore a generalized cohomology theory) called topological modular form theory  $TMF$ . There is a map

$$TMF^{-n}(\mathrm{pt}) \rightarrow \{\text{integral modular forms of weight } n/2\}.$$

## 2. EXAMPLES: $H$ , $K$ , AND $TMF$

We begin with a few remarks concerning our discussion from last time.

- i) Last time we claimed that  $\tilde{h}^n(\mathrm{pt}) = 0$  for each  $n$ . This is easy to prove using the LES associated to cofibration  $i: A \rightarrow X$ . If we take  $A = X = \mathrm{pt}$ , then  $i$  is the identity map. It follows that  $i^*$  is an isomorphism by the functor property and thus  $\tilde{h}^n(X/A) = \tilde{h}^n(\mathrm{pt}) = 0$ .
- ii) If  $X$  and  $Y$  are topological spaces with base points  $x \in X$  and  $y \in Y$  (with mild additional hypotheses like “well-pointed” etc., which we suppress here) then the wedge of these spaces is  $X \vee Y := (X \amalg Y)/(x \sim y)$ . Note that  $X \vee Y$  has a base point, namely  $x \sim y$ . If  $i: X \rightarrow X \vee Y$  and  $j: Y \rightarrow X \vee Y$  are the inclusion maps, then  $i$  and  $j$  are cofibrations. The LES associated to

$$X \xrightarrow{i} X \vee Y \xleftarrow[p]{j} X \vee Y/X = Y$$

is

$$\cdots \longleftarrow \tilde{h}^n(X) \xleftarrow{i^*} \tilde{h}^n(X \vee Y) \xleftarrow[p^*]{j^*} \tilde{h}^n(Y) \xleftarrow{\delta} \cdots$$

Since  $j^* \circ p^* = \mathrm{id}$ ,  $p^*$  must be injective and hence  $\delta$  is the zero map. Thus, the portion of the LES displayed is actually a short exact sequence (SES) and  $j^*$  is a section, so the sequence is split. This implies that  $\tilde{h}^n(X \vee Y) \simeq \tilde{h}^n(X) \oplus \tilde{h}^n(Y)$  for each  $n$ .

Let us introduce some notation. We will write  $X_+$  for  $X \amalg \text{pt}$ . Recall from lecture 1 that  $h^n(X) := \tilde{h}^n(X_+)$ . From the previous remark it then follows that  $h^n(X \amalg Y) = h^n(X) \oplus h^n(Y)$  for each  $n$ . One should take from this that the wedge is to pointed spaces what disjoint union is to general spaces.

- iii) The reduced cohomology of  $S^n$  for each  $n$  determines the coefficients of the corresponding unreduced theory. Indeed,  $\tilde{h}^q(S^n) = \tilde{h}^q(\Sigma S^{n-1}) \simeq \tilde{h}^{q-1}(S^{n-1}) \simeq \dots \simeq \tilde{h}^{q-n}(S^0) \simeq \tilde{h}^{q-n}(\text{pt}_+) \simeq h^{q-n}(\text{pt})$ . More generally,  $h^{q-n}(X) = \tilde{h}^{q-n}(X_+) \simeq \tilde{h}^q(\Sigma^n X_+)$ .

*Example 2.1.* For compact manifold  $X$ , we define  $K^{-n}(X) := \tilde{K}^0(\Sigma^n X_+)$  for  $n > 0$ . The Bott-Periodicity theorem tells us that the sequence has period 2 and we formally extend to non-negative indices by requiring this periodicity to hold.

**Definition 2.2.** A *multiplicative GCT* is a GCT  $h^n$  together with a product

$$\cup: h^m(X) \otimes_{\mathbb{Z}} h^n(X) \rightarrow h^{m+n}(X)$$

which is associative, graded commutative, product is natural in  $X$ .

For a multiplicative GCT  $h$  we then define  $h^*(X)$  as a ring to be the  $\mathbb{Z}$ -module  $\bigoplus_{n \in \mathbb{Z}} h^n(X)$  together with the product  $\cup$ . Here are some examples of multiplicative GCT's.

- Example 2.3.*
- i) Ordinary cohomology  $H^*(X)$  with the ordinary cup product.
  - ii) When  $X$  is a manifold, the wedge product on forms induces a product in de Rham cohomology. Via the de Rham isomorphism the ordinary cohomology is isomorphic as a ring to the ordinary cohomology of  $X$  with real coefficients.
  - iii)  $K^*(X)$  (on  $K^0(X)$  this multiplication is induced by tensor product of vector bundles).
  - iv)  $TMF^*(X)$ .

One reason to work with cohomology as opposed to homology is that cohomology (coefficients in a field) has an algebra structure whereas homology has the structure of a co-algebra and we are used to working with algebras.

Returning now to the subject of topological modular forms, let us note that there are two flavors of the subject. One is the “connective<sup>3</sup> version,” the GCT  $\text{tmf}^*$  and the other is the “periodic<sup>4</sup> version,” the GCT  $\text{TMF}^*$ . More precisely, there exists a “periodicity element”  $u \in \text{tmf}^{-24^2}(\text{pt})$  and a map  $\text{tmf}^*(X) \rightarrow \text{TMF}^*(X)$  which we can use to think of  $u$  as an element of  $\text{TMF}^{-24^2}(\text{pt})$ . If  $\pi: X \rightarrow \text{pt}$  denotes the projection, then the map

$$\begin{aligned} \text{TMF}^n(X) &\rightarrow \text{TMF}^{n-24^2}(X) \\ \alpha &\mapsto \pi^*u \cup \alpha \end{aligned}$$

<sup>3</sup>In general a GCT  $h$  is said to be *connective* if  $h^n(\text{pt}) = 0$  for  $n > 0$ .

<sup>4</sup>A GCT  $h$  is *periodic* if there exists  $\ell$  such that  $h^n \leftarrow h^{n+\ell}$  for each  $n$ .

is an isomorphism. The map  $\mathrm{tmf}^*(X) \rightarrow \mathrm{TMF}^*(X)$  factors through the localization  $\mathrm{tmf}^*(X)[u^{-1}]$  at  $u$ , to an isomorphism

$$\begin{array}{ccc} \mathrm{tmf}^*(X) & \xrightarrow{\quad\quad\quad} & \mathrm{TMF}^*(X) \\ & \searrow & \nearrow \\ & \mathrm{tmf}^*(X)[u^{-1}] & \end{array}$$

specified by  $\frac{\alpha}{u^k} \mapsto u^{-k}(\alpha)$ . This is an isomorphism of graded commutative rings if we specify  $\deg \left[ \frac{\alpha}{u^k} \right] = \deg \alpha - k(-24^2)$ . In other words, adjoining  $u^{-1}$  makes  $\mathrm{tmf}^*$  periodic.

Let's examine the analog of this in  $K$ -theory. A convention in topology is to denote connective theories by lower case letters and periodic theories by upper case letters. Connective  $K$ -theory is denoted  $k^*(X)$  and periodic  $K$ -theory is denoted  $K^*(X)$ . By Bott's periodicity theorem, we know that  $K^*(X)$  is 2-periodic. The periodicity element we will denote by  $u \in K^{-2}(\mathrm{pt}) = \tilde{K}^{-2}(S^0) \simeq \tilde{K}^0(S^2)$  (suspension isomorphism). Viewed as an element of  $\tilde{K}^0(S^2)$ ,  $u$  is the difference of the trivial line bundle from the Hopf line bundle. The analog of the isomorphism above says that  $K^*(X) \simeq k^*(X)[u^{-1}]$ . As a graded ring  $K^*(\mathrm{pt}) \simeq \mathbb{Z}[u, u^{-1}]$  where  $u$  has degree  $-2$ , whereas  $k^*(\mathrm{pt}) \simeq \mathbb{Z}[u]$ . So we see that you pass from connective to periodic  $K$ -theory by inverting the periodicity element.

We will finish today with some more background on modular forms. As before, let  $\mathfrak{h}$  denote the upper half plane in  $\mathbb{C}$  and recall that  $\tau \mapsto e^{2\pi i\tau}$  is a biholomorphism of the cylinder  $\mathfrak{h}/\mathbb{Z}$  with the punctured unit disk  $\mathbb{D}_0$ . Any  $\mathbb{Z}$ -periodic holomorphic function on  $\mathfrak{h}$  can then be regarded as a function of  $q$ , holomorphic in  $\mathbb{D}_0$ .

**Definition 2.4.** A *modular form* of weight  $k$  is a holomorphic function  $f: \mathfrak{h} \rightarrow \mathbb{C}$  such that

- i)  $f(A\tau) = (c\tau + d)^k f(\tau)$  for each  $A = \begin{pmatrix} a & b \\ c & d \end{pmatrix} \in \mathrm{SL}(2, \mathbb{Z})$
- ii)  $f$  is holomorphic at  $i\infty$ , i.e., the  $q$ -expansion  $f = \sum_{n \in \mathbb{Z}} a_n q^n$  has  $a_n = 0$  for  $n < 0$ .

We write  $M_k$  for the set of modular forms of weight  $k$  and note that  $M_k$  is naturally a complex vector space. Then we set  $M_* = \bigoplus_{k \in \mathbb{Z}} M_k$  and regard it as a  $\mathbb{Z}$ -graded  $\mathbb{C}$ -algebra. After all, the pointwise product of a modular form of weight  $k$  with one of weight  $\ell$  is a modular form of weight  $k + \ell$ .

We state without proof the following result from the theory of modular forms.

**Theorem 2.5.**  $M_* = \mathbb{C}[c_4, c_6]$  where the subscript denotes the weight and

$$c_4 = 1 + 240 \sum_{n>0} \sigma_3(n) q^n,$$

$$c_6 = 1 - 504 \sum_{n>0} \sigma_5(n) q^n$$

and  $\sigma_r(n) = \sum_{d|n} d^r$ .

**Definition 2.6.** A modular form is *integral* if the coefficients in its  $q$ -expansion are integers.

In order to keep track of the reversal of signs and weights and factors of two, we offer the following non-standard notation. Let

$$\mathrm{mf}^n = \{\text{integral modular forms of weight } -\frac{n}{2}\}$$

and set

$$\mathrm{mf}^* = \bigoplus_{n \in \mathbb{Z}} \mathrm{mf}^n$$

as a  $\mathbb{Z}$ -graded ring. Writing the superscript  $n$  on  $\mathrm{mf}^n$  is in analogy with cohomology and is intended to help us to remember that the weight is negative. With this notation, we can finish by stating a remarkable and non-trivial theorem.

**Theorem 2.7.** *There exists a ring homomorphism  $\mathrm{tmf}^* \rightarrow \mathrm{mf}^*$  which is an isomorphism rationally. (Here  $\mathrm{tmf}^*$  is shorthand for  $\mathrm{tmf}^*(\mathrm{pt})$ .)*

### 3. COEFFICIENTS OF TMF

From last time, recall the assertion that there is a homomorphism of graded rings

$$\Phi: \mathrm{tmf}^* = \bigoplus_{n \in \mathbb{Z}} \mathrm{tmf}^n \longrightarrow \mathrm{mf}^* = \bigoplus_{n \in \mathbb{Z}} \mathrm{mf}^n \subset \mathbb{C}[c_4, c_6]$$

which is a rational isomorphism. To help eliminate some forehead wrinkling regarding weights, minus signs, and factors of 2, we introduce the following non-standard terminology.

**Definition 3.1.** The *degree* of a modular form is  $n$  when the weight  $-\frac{n}{2}$ .

Thus  $\mathrm{mf}^n$  denotes the modular forms of degree  $n$ . Note that  $c_4 \in \mathrm{mf}^{-8}$  and  $c_6 \in \mathrm{mf}^{-12}$ . Unfortunately, we are stuck with the indices 4 and 6 which don't match with the superscripts  $-8$  and  $-12$ , but otherwise these notations and conventions seem to be a good idea.

It is a good question now to ask what  $\mathrm{mf}^*$  is as a graded ring. One might hope that  $\mathrm{mf}^* = \mathbb{Z}[c_4, c_6]$ , but this turns out to be not quite correct. Here is an integral modular form, *the discriminant*,

$$\Delta = q \prod_{n=1}^{\infty} (1 - q^n)^{24}$$

with  $\Delta = \frac{1}{1728}(c_4^3 - c_6^2)$ , so it does not lie in  $\mathbb{Z}[c_4, c_6]$ . It's weight is 12 and thus its degree is  $-24$ . The remarkable fact is that by adjoining  $\Delta$  to  $\mathbb{Z}[c_4, c_6]$  and imposing the above relation, all integral modular forms are obtained.

**Theorem 3.2.**  $\mathrm{mf}^* = \mathbb{Z}[c_4, c_6, \Delta]/(c_4^3 - c_6^2 - 1728\Delta)$

Another interesting fact is that the periodicity element  $u \in \mathrm{tmf}^{-24^2}$  is carried by the map  $\Phi$  onto  $\Delta^{24} \in \mathrm{mf}^{-24^2}$ . As a corollary, it follows that map induced by  $\Phi$

$$\mathrm{TMF}^* \simeq \mathrm{tmf}^*[u^{-1}] \longrightarrow \mathrm{mf}^*[\Delta^{-1}]$$

given by  $\alpha/u^k \mapsto \Phi(\alpha)/\Phi(u^k) = \Phi(\alpha)/\Delta^{24k}$  is a rational isomorphism.

**Definition 3.3.** A *weakly holomorphic modular form* is a holomorphic function  $f: \mathfrak{h} \rightarrow \mathbb{C}$  with the same properties as a modular form with the exception that the  $q$ -series expansion may exhibit at worst a pole type singularity at  $0 \in \mathbb{D}$ .

By  $\mathrm{MF}^n$  we will denote the additive abelian group of weakly holomorphic integral modular forms of weight  $-n/2$ , and write

$$\mathrm{MF}^* = \bigoplus_{n \in \mathbb{Z}} \mathrm{MF}^n$$

for the graded ring. Recall that  $\mathrm{mf}^n = 0$  for each  $n > 0$ . For comparison, note that  $\mathrm{MF}^{24} \neq 0$  since  $\Delta^{-1}$  has a simple pole at zero in the disk.

**Lemma 3.4.**  $\mathrm{MF}^* \simeq \mathrm{mf}^*[\Delta^{-1}]$ . *In particular,  $\mathrm{MF}$  is periodic with period 24.*

*Proof.* Essentially, we can regard  $\mathrm{MF}$  as included in  $\mathrm{mf}^*[\Delta^{-1}]$ , provided we interpret this correctly. If  $f$  has a pole of order  $N$  at  $q = 0$ , then  $f\Delta^N$  is holomorphic at  $q = 0$  and thus defines an element of  $\mathrm{mf}^*$ . The map

$$f \mapsto \frac{f\Delta^N}{\Delta^N}$$

then identifies  $f$  with an element of  $\mathrm{mf}^*[\Delta^{-1}]$ , and this prescription for the image of each  $f$  determines a well defined injective homomorphism of graded rings. The inverse is determined by the assignment  $\frac{g}{\Delta^N} \mapsto g\Delta^{-N}$ .  $\square$

As a side comment, note that the ring  $\mathbb{C}[c_4, c_6][(c_4^3 - c_6^2)^{-1}]$  is isomorphic to the ring of weakly holomorphic modular forms. Now  $\mathrm{MF}^*$  is periodic with period 24 with periodicity element  $\Delta$ . Whereas  $\mathrm{TMF}^*$  is periodic with period  $24^2$ . Why? The smallest power of  $\Delta$  in the image of  $\Phi$  is 24. So we see that  $\Phi$  is *not* an integral isomorphism.

We'll finish today with some discussion of the coefficient groups of  $\mathrm{tmf}$ . These are finitely generated abelian groups and a standard method in topology for determining these groups is localization and the Adam's spectral sequence.

Given  $p$  prime in  $\mathbb{Z}$ , recall that  $\mathbb{Z}$  *localized at*  $(p)$  is the local ring

$$\mathbb{Z}_{(p)} = \left\{ \frac{a}{b} \in \mathbb{Q} : b \text{ prime to } p \right\}.$$

Given an abelian group  $A$ , the  $p$ -*localization* of  $A$  is

$$A_{(p)} := A \otimes_{\mathbb{Z}} \mathbb{Z}_{(p)}.$$

For example, if  $q \in \mathbb{Z}$  is prime then  $(\mathbb{Z}/q^k\mathbb{Z})_{(p)}$  is zero if  $q \neq p$  and  $\mathbb{Z}/q^k\mathbb{Z}$  if  $q = p$ . If  $A$  is a finitely generated abelian group, then it is isomorphic to a direct sum of a free abelian group with a direct sum of cyclic subgroups of the form  $\mathbb{Z}/q^k\mathbb{Z}$ . Thus  $A_{(p)}$  is a sum of  $\mathbb{Z}_{(p)}$ 's and  $(\mathbb{Z}/q^k\mathbb{Z})$ 's for  $q = p$ . In other words, localization at  $(p)$  throws away all cyclic factors not involving  $p$ . By computing the localizations at all primes  $p$ , one can thus reconstruct  $A$ .

What makes things computable in  $\mathrm{tmf}$  is the fact that

$$\mathrm{tmf}^* \xrightarrow{\Phi} \mathrm{mf}^*$$

induces an isomorphism of  $p$ -localizations for  $p \neq 2, 3$ . This implies that the  $p$ -torsion in  $\mathrm{tmf}^*$  can occur only for  $p = 2$  and  $p = 3$ . Tillman Bauer used the Adam's spectral sequence to compute the 2-localization and 3-localization of the  $\mathrm{tmf}$  groups up through degree 24. Table 1 shows these localizations and the composite information for  $\mathrm{tmf}$ .

TABLE 1. Coefficient groups of  $\text{tmf}$ . Localizations at 2 and 3 and the compositions are shown as determined from the calculations of Hopkins and Bauer. If an entry appears blank, then that coefficient group or localization is zero.

$n$	0	1	2	3	4	5	6	7	8	9	10	11	12
$\text{tmf}_{(3)}^{-n}$	$\mathbb{Z}_{(3)}$			$\mathbb{Z}/3\mathbb{Z}\alpha$					$\mathbb{Z}_{(3)}c_4$		$\mathbb{Z}/3\mathbb{Z}\beta$		$\mathbb{Z}_{(3)}c_6$
$\text{tmf}_{(2)}^{-n}$	$\mathbb{Z}_{(2)}$	$\mathbb{Z}/2\mathbb{Z}$	$\mathbb{Z}/2\mathbb{Z}$	$\mathbb{Z}/8\mathbb{Z}$			$\mathbb{Z}/2\mathbb{Z}$		$\mathbb{Z}_{(2)}c_4 \oplus \mathbb{Z}/2\mathbb{Z}$	$\mathbb{Z}/2\mathbb{Z}$	$\mathbb{Z}/2\mathbb{Z}\beta$		$\mathbb{Z}_{(2)}c_6$
$\text{tmf}^{-n}$	$\mathbb{Z}$	$\mathbb{Z}/2\mathbb{Z}$	$\mathbb{Z}/2\mathbb{Z}$	$\mathbb{Z}/24\mathbb{Z}$			$\mathbb{Z}/2\mathbb{Z}$		$\mathbb{Z}c_4 \oplus \mathbb{Z}/2\mathbb{Z}$	$\mathbb{Z}/2\mathbb{Z}$	$\mathbb{Z}/6\mathbb{Z}\beta$		$\mathbb{Z}c_6$
$n$	13	14	15	16	17	18	19	20	21	22	23	24	
$\text{tmf}_{(3)}^{-n}$	$\mathbb{Z}/3\mathbb{Z}\alpha\beta$			$\mathbb{Z}_{(3)}c_4^2$				$\mathbb{Z}_{(3)}c_4c_6 \oplus \mathbb{Z}/3\mathbb{Z}\beta^2$				$\mathbb{Z}_{(3)}3\Delta \oplus \mathbb{Z}_{(3)}c_4^3$	
$\text{tmf}_{(2)}^{-n}$		$\mathbb{Z}/2\mathbb{Z}$	$\mathbb{Z}/2\mathbb{Z}$	$\mathbb{Z}_{(2)}c_4^2$	$(\mathbb{Z}/2\mathbb{Z})^2$	$\mathbb{Z}/2\mathbb{Z}$		$\mathbb{Z}_{(2)}^2c_4c_6 \oplus \mathbb{Z}/8\mathbb{Z}\beta^2$				$\mathbb{Z}_{(2)}8\Delta \oplus \mathbb{Z}_{(2)}c_4^3$	
$\text{tmf}^{-n}$	$\mathbb{Z}/3\mathbb{Z}\alpha\beta$	$\mathbb{Z}/2\mathbb{Z}$	$\mathbb{Z}/2\mathbb{Z}$	$\mathbb{Z}c_4^2$	$(\mathbb{Z}/2\mathbb{Z})^2$	$\mathbb{Z}/2\mathbb{Z}$		$\mathbb{Z}2c_4c_6 \oplus \mathbb{Z}/24\mathbb{Z}\beta^2$				$\mathbb{Z}24\Delta \oplus \mathbb{Z}c_4^3$	

## 4. COMPACTLY SUPPORTED GCT'S

The point from the last lecture is that the groups  $\mathrm{tmf}^n(\mathrm{pt})$  can be completely computed. Of course, rationally we understand what they are because the map  $\Phi$  is a rational isomorphism. But to understand torsion we need to look to the paper of Tillman Bauer [B].

Today we will make progress towards showing how to use  $\mathrm{tmf}$  to associate invariants to manifolds. Doing that will require some preliminary discussion of the Thom isomorphism and  $B$ -structures.

Let  $X$  be a locally compact Hausdorff (LCH) topological space.

**Definition 4.1.** The *1-point compactification* of  $X$ , denoted  $X_+$ , is the disjoint union  $X \amalg \{\infty\}$  with the topology consisting of the following open sets

- Each  $\mathcal{U} \subset X_+$  such that  $\mathcal{U} \subset X$  is open in  $X$ ;
- $(X \setminus K) \amalg \{\infty\}$  where  $K$  is a compact subset of  $X$ .

Note that if  $X$  is compact, then  $X_+ = X \amalg \{\infty\}$  not just as a set, but also as a topological space. So there is no clash with the previous notation of  $X_+$ , as we were discussing  $X$  compact before.

*Example 4.2.* i)  $(\mathbb{R}^n)_+ \simeq S^n$ .

- ii)  $(X \times Y)_+ \simeq X_+ \wedge Y_+$ . Recall here that the smash product  $\wedge$  of two pointed spaces is the Cartesian product  $X \times Y$  modulo the relation where

$$X \times \infty_Y \cup \infty_X \times Y$$

is identified to a point which is the base point in  $X_+ \wedge Y_+$ .

- iii)  $(X \times \mathbb{R}^n)_+ \simeq X_+ \wedge S^n \simeq \Sigma^n X_+$ .
- iv) If  $p: E \rightarrow X$  is a real vector bundle over  $X$  base  $X$ , then  $E_+$  is isomorphic to the disk bundle  $D(E)$  modulo the sphere bundle  $S(E)$  and this can be identified with the Thom space when  $X$  is compact. The idea to take away from this is that the Thom space is a generalization of the suspension.

If  $f: X \rightarrow Y$  is a continuous map then we define a map  $f_+: X_+ \rightarrow Y_+$  in the obvious way by extension, sending  $\infty \mapsto \infty$ . However, this map is continuous only if  $f$  is a proper map.

Let  $h^*$  be a multiplicative *GCT*. From now on, we will assume that multiplicative *GCT*'s have units  $1 \in h^0(X)$  which will act as a unit with respect to the cup product.

**Definition 4.3.** For  $X$  a LCH topological space we define *h-cohomology with compact supports* by  $h_c^n(X) := \tilde{h}^n(X_+)$ .

The cup product extends to a multiplication  $h_c^m(X) \otimes h^n(X) \rightarrow h_c^{m+n}(X)$ . Note that the lack of a  $c$  subscript in the second factor is not a typo. The product of a cohomology class with a compactly supported cohomology class is again compactly supported.

Now, let  $p: E \rightarrow X$  be a rank  $k$  real vector bundle over a compact Hausdorff space  $X$ . Let  $x \in X$  and denote by  $i_x: E_x \rightarrow E$  the fiber inclusion in  $E$  (which is a proper map). This induces a map  $h_c^k(E) \rightarrow h^0(\mathrm{pt})$  given by the composition

$$h_c^k(E) \xrightarrow{(i_x)^*} h_c^k(E_x) \xrightarrow{\sim} \tilde{h}^k((E_x)_+) \xrightarrow{\sim} \tilde{h}^k(S^k) \xrightarrow{\sim} \tilde{h}^0(S^0) = h^0(\mathrm{pt}).$$

**Definition 4.4.** An  $h$ -Thom class, or  $h$ -orientation, of  $E$  is a cohomology class  $\mathcal{U} \in h_c^k(E)$  such that for each  $x \in X$ ,  $\mathcal{U} \mapsto 1 \in h^0(\text{pt})$  under the map  $h_c^k(E) \rightarrow h^0(\text{pt})$  induced by the fiber inclusion  $i_x: E_x \rightarrow E$ .

**Theorem 4.5.** *The following map is an isomorphism called the Thom isomorphism.*

$$\begin{aligned} h^q(X) &\rightarrow h_c^{q+k}(E) \\ \alpha &\mapsto p^*\alpha \cup \mathcal{U} \end{aligned}$$

The proof of this theorem is not hard. But note that if  $E$  is the trivial vector bundle over  $X$ , then the Thom isomorphism is the suspension isomorphism. The philosophy here is that having an  $h$ -orientation means that  $E$  and the trivial bundle are not distinguished by  $h$ .

Moving on, we now want to discuss orientations, spin structures, string structures, and  $B$ -structures. By  $G_n(\mathbb{R}^k)$  we denote the grassmannian of  $k$ -planes in  $\mathbb{R}^n$ . For fixed  $n$ , these spaces can be regarded as included in one another

$$\dots \subset G_n(\mathbb{R}^k) \subset G_n(\mathbb{R}^{k+1}) \subset \dots$$

**Definition 4.6.** By  $\text{BO}(n)$  we denote the union  $\bigcup_k G_n(\mathbb{R}^k)$  with the direct limit topology.

The space  $\text{BO}(n)$  is often referred to as the classifying space for the orthogonal group  $O(n)$  but one can also regard this as the classifying space for rank  $n$  real vector bundles. Over  $\text{BO}(n)$  there is a tautological vector bundle  $\gamma^n$  whose fiber over an  $n$ -dimensional subspace  $V$  of some  $\mathbb{R}^k$  is simply  $V$  itself together with the obvious projection map. The isomorphism classes of rank  $n$  real vector bundles over  $X$  are in bijection with the homotopy classes of maps  $X \rightarrow \text{BO}(n)$ . Given a map  $f: X \rightarrow \text{BO}(n)$ , the pullback  $f^*\gamma^n$  is a vector bundle over  $X$  and the map  $f$  is called a classifying map for this vector bundle.

Note that there are inclusions  $\text{BO}(n) \subset \text{BO}(n+1) \subset \dots$  so that we can define

$$\text{BO} = \bigcup_n \text{BO}(n)$$

with the direct limit topology. Let  $B \rightarrow \text{BO}$  be a fibration and let  $p: E \rightarrow X$  be a rank  $n$  real vector bundle over  $X$  with classifying map  $f: X \rightarrow \text{BO}(n)$ .

**Definition 4.7.** A  $B$ -structure on  $E$  is a lift  $\tilde{f}$  of  $f$  making the following diagram commute on the nose (not just up to homotopy).

$$\begin{array}{ccc} & & B \\ & \nearrow \tilde{f} & \downarrow \\ X & \xrightarrow{f} & \text{BO}(n) \subset \text{BO} \end{array}$$

More precisely, a  $B$ -structure is a homotopy class of such lifts where the homotopy must be through a family of such lifts.

**Theorem 4.8.** *If  $Y$  is a LCH topological space then there exists a fibration*

$$p: Y\langle n \rangle \rightarrow Y$$

*for each  $k = 1, 2, \dots$  which is characterized up to fiber homotopy equivalence by the following properties*

- a)  $\pi_\ell(Y\langle n \rangle) = 0$  for  $\ell < n$

b)  $p_* : \pi_\ell(Y\langle n \rangle) \rightarrow \pi_\ell Y$  is an isomorphism for each  $\ell \geq n$ .

**Definition 4.9.** The space  $Y\langle n \rangle$  is called the  $(n - 1)$ -connected cover of  $Y$ .

For example  $Y\langle 1 \rangle$  is the connected component of the base point in  $Y$  and  $Y\langle 2 \rangle$  is the universal cover of  $Y$ . For higher  $n$ , it is more difficult to describe.

The Bott periodicity theorem, together with the fact that  $\pi_{\ell+1}BG = \pi_\ell G$  for each  $\ell$  if  $G$  is a topological group, tells us that the following table completely characterizes the homotopy groups of  $BO$ . What this tells us is that  $BO\langle 1 \rangle = BO$ ,

$n$	0	1	2	3	4	5	6	7	8
$\pi_n BO$	0	$\mathbb{Z}/2\mathbb{Z}$	$\mathbb{Z}/2\mathbb{Z}$	0	$\mathbb{Z}$	0	0	0	$\mathbb{Z}$

but  $BO\langle 2 \rangle$  is different. In fact  $BO\langle 2 \rangle = BSO$ . Similarly,  $BO\langle 3 \rangle = BO\langle 2 \rangle$ , but  $BO\langle 4 \rangle$  is different. The following diagram shows the non-trivial  $(n - 1)$ -connected covers up through  $n = 8$ .

$$\begin{array}{ccc}
 & & BO\langle 8 \rangle & = & BString \\
 & & \downarrow & & \\
 & & BO\langle 4 \rangle & = & BSpin \\
 & & \downarrow & & \\
 & & BO\langle 2 \rangle & = & BSO \\
 & & \downarrow & & \\
 X & \xrightarrow{f} & BO & & 
 \end{array}$$

In each case the vertical maps are fibrations and we see the dictionary to the classifying spaces of the groups  $SO$ ,  $Spin$  and another group called  $String$ . The latter is not a compact Lie group, it is an infinite dimensional topological group best thought of as a 2-group, but we will not discuss that here.

The dictionary is as follows:

- A  $BO\langle 2 \rangle$  structure on  $E$  corresponds to an *orientation* on  $E$
- A  $BO\langle 4 \rangle$  structure on  $E$  corresponds to a *spin structure* on  $E$ .
- A  $BO\langle 8 \rangle$  structure on  $E$  corresponds to a *string structure* on  $E$ .

The theory of characteristic classes determines for us computable obstructions to the existence of such structures. For example, a  $BO\langle 2 \rangle$  structure exists  $\Leftrightarrow$  the restriction of  $E$  to any  $S^1$  is trivial  $\Leftrightarrow$  the restriction of  $E$  to the 1-skeleton is trivial  $\Leftrightarrow$  the first Stiefel-Whitney class  $w_1 E \in H^1(X, \mathbb{Z}/2\mathbb{Z})$  is zero. A  $BO\langle 4 \rangle$  structure exists  $\Leftrightarrow$   $E$  is trivial over 2-skeleton  $\Leftrightarrow$   $w_1 E = 0$  and  $w_2 E = 0$ . A  $BO\langle 8 \rangle$  structure exists  $\Leftrightarrow$   $w_1 E = 0$ ,  $w_2 E = 0$ , and  $(p_1 E)/2 \in H^4(X, \mathbb{Z})$  is zero ( $p_1 E$  is the first Pontryagin class of  $E$  and if  $w_1 E = 0$  and  $w_2 E = 0$  it is always divisible by 2 in  $H^4(X, \mathbb{Z})$ ).

**Theorem 4.10.** *An orientation on  $E$  determines an  $H^*(\cdot, \mathbb{Z})$ -orientation on  $E$ .*

**Theorem 4.11** (Atiyah). *A spin structure on  $E$  determines a  $KO$ -orientation (and similarly a  $ko$ -orientation) on  $E$ .*

A  $Spin^c$  structure determines a  $K$ -orientation, but this does not fit with the connected cover discussion of  $O(n)$  above.

**Theorem 4.12** (Hopkins, Ando, Strickland). *A string structure on  $E$  determines a TMF-orientation (and similarly a tmf-orientation) on  $E$ .*

## 5. THE PUSH-FORWARD MAP, BORDISM GROUPS, AND INVARIANTS

The Thom isomorphism basically says that the cohomology of the base and the cohomology with compact supports of a bundle are the same in the presence of an  $h$ -orientation. Our goal today is to get mileage out of the Thom isomorphism to construct invariants of spaces.

Recall that if  $E \rightarrow X$  is a rank  $n$  real vector bundle over  $X$  then an  $h$ -orientation on  $E$ , or  $h$ -Thom class, is a cohomology class  $\mathcal{U} \in h_c^n(E)$  such that for each  $x \in X$  the map  $h_c^n(E) \rightarrow h^0$  induced by the fiber inclusion  $i_x: E_x \rightarrow E$  sends  $\mathcal{U}$  to the unit  $1 \in h^0$ .

Let's consider de Rham cohomology, so  $h^n = H_{DR}^n$ . The composition of the isomorphisms

$$H_c^n(\mathbb{R}^n) \longrightarrow \tilde{H}^n(\mathbb{R}_+^n) \longrightarrow H^0(\text{pt}) \longrightarrow \mathbb{R}$$

is equivalent to integration over  $\mathbb{R}^n$ . We consider the  $n$ -form associated to the normalized Gaussian with mean zero and variance  $1/t$ ,

$$\omega_t = \frac{t^{n/2}}{(2\pi)^{n/2}} e^{-t\|x\|^2/2} dx_1 \wedge \dots \wedge dx_n.$$

While not compactly supported in the usual sense of differential forms on  $\mathbb{R}^n$ , it does extend smoothly to the 1-point compactification, so  $[\omega_t] \in h_c^n(\mathbb{R}^n)$  by definition. We see here that the notion of compact support we have defined is slightly weaker than the usual notion of compact support.

Since  $\omega_t$  integrates to the unit 1 in  $\mathbb{R}$  for each  $t$ , our goal is then to construct  $\mathcal{U}_t$  such that  $(i_x^*)(\mathcal{U}_t) = [\omega_t]$ . Here is one idea. Choose a metric in  $E$  and a connection in  $E$ . Write down this form in each fiber and compose with the projection defined by the connection onto the vertical subspace of the tangent space to  $E$ . This way, we get a form on  $E$  with compact support. The difficult part is that one needs to show that such a form is closed so that it represents a cohomology class.

**Theorem 5.1** (Matthai-Quillen). *If  $E \rightarrow X$  is an oriented vector bundle then there exists a compactly supported closed differential form  $\mathcal{U}_t$  on  $E$  such that  $\mathcal{U}_t|_{E_x} = \omega_t$  for each  $x \in X$ .*

In the proof of this theorem they identify the correction to the above construction which guarantees a closed representative with the desired properties. In the presence of an orientation of  $E$  this correction is possible.

Let  $M$  be a closed manifold of dimension  $n$ . An embedding  $i: M \rightarrow \mathbb{R}^{n+k}$  determines a “normal Gauss map”  $M \rightarrow G_k(\mathbb{R}^{n+k})$  sending  $x \in M$  to the normal space  $\nu_x M$  at  $i(x)$  in  $i(M)$ . The normal Gauss map is the classifying map of the vector bundle  $\nu M$ .

**Definition 5.2.** A (normal)  $B$ -structure (resp.  $h$ -orientation) on  $M$  consists of:

- i) an embedding  $i: M \rightarrow \mathbb{R}^{n+k}$ , and
- ii) a  $B$ -structure (resp.  $h$ -orientation) on  $\nu M$ .

By the Tubular Neighborhood Theorem, we can view  $\nu M$  as a submanifold of  $\mathbb{R}^{n+k}$ . We then define a *collapsing map*  $c: \mathbb{R}_+^{n+k} \rightarrow \nu_+$  by the assignment  $x \mapsto x$  if

$x \in \nu M$  and  $x \mapsto \infty$  if  $x \notin \nu M$ . Now we are in business because we can construct a map  $\pi_! : h^q(M) \rightarrow h^{q-n}(\text{pt})$  as the composition of the Thom isomorphism followed by the defining map of compactly supported cohomology followed by  $c^*$  followed by the suspension isomorphism.

$$\begin{array}{ccccccc}
 h^q(M) & \xrightarrow{\sim} & h_c^{q+k}(\nu M) & \xrightarrow{\sim} & \tilde{h}^{q+k}(\nu_+) & \xrightarrow{c^*} & \tilde{h}^{q+k}(\mathbb{R}^{n+k}_+) \\
 & & & & & & \downarrow \sim \\
 & & & & & & h^{q-n}(\text{pt}) \\
 & \searrow \pi_! & & & & & \\
 & & & & & & 
 \end{array}$$

The map  $\pi_!$  is read “Pi lower shriek” and is the push-forward map in cohomology.<sup>5</sup>

*Example 5.3.* What is the push-forward map in de Rham cohomology  $h^n = H_{DR}^n$ ?

$$\pi_! : H_{dR}^q(M) \rightarrow H_{dR}^{q-n} = \begin{cases} 0 & q \neq n \\ \mathbb{R} & q = n \end{cases}$$

It is the zero map unless  $q = n$ , in which case it is given by integration over  $M$ . Indeed, given a closed  $n$ -form, we multiply by the Thom form to get a closed  $n$ -form on  $\nu(M)$ . Viewed in a tubular neighborhood, this gives a closed  $(n+k)$ -form vanishing at the boundary on a pre-compact open submanifold of  $\mathbb{R}^{n+k}$ . Extending by zero, we obtain a closed  $(n+k)$ -form on all of  $\mathbb{R}^{n+k}$ . The form is the Thom form in fiber directions and we use the Fubini theorem to integrate along the fibers obtaining no contribution to the integral since the Thom form integrates to 1 in each fiber. The only thing left is the integral over  $M$  of the closed form we began with. The moral of this story is that one should view the push-forward map  $\pi_!$  as an integration.

It is important that we used the normal bundle here. For orientation, spin, and string structures it turns out not to matter whether we used the normal bundle or the tangent bundle here. But for other structures (e.g. Pin-structures) these are different.

**Definition 5.4.** If  $M$  is equipped with a normal  $h$ -orientation, then we define an invariant

$$\alpha(M) := \pi_!(1) \in h^{-n}(\text{pt})$$

More explicitly,  $\pi_!(1)$  is the image under the suspension isomorphism of  $c^*(\mathcal{U})$ .

Let  $I = [0, 1]$  denote the unit interval. We now define a notion of bordism for manifolds with  $B$ -structure. Here is a loose version of the definition.

**Definition 5.5.** Let  $M_0$  and  $M_1$  be closed manifolds of dimension  $n$  with normal  $B$ -structures. A *bordism* between  $M_0$  and  $M_1$  is a manifold with boundary  $W$  of dimension  $n+1$  embedded in  $\mathbb{R}^{n+k} \times I$  equipped with a normal  $B$ -structure such that the restriction to  $\mathbb{R}^{n+k} \times \{\ell\}$  is  $M_\ell$  for  $\ell = 0, 1$  with normal  $B$ -structure. If there exists a bordism between  $M_0$  and  $M_1$ , we say that  $M_0$  and  $M_1$  are *bordant*.

<sup>5</sup>Note that  $M$  must be a closed manifold for this to work. The existence of  $\pi_!$  really does depend on all of the data.

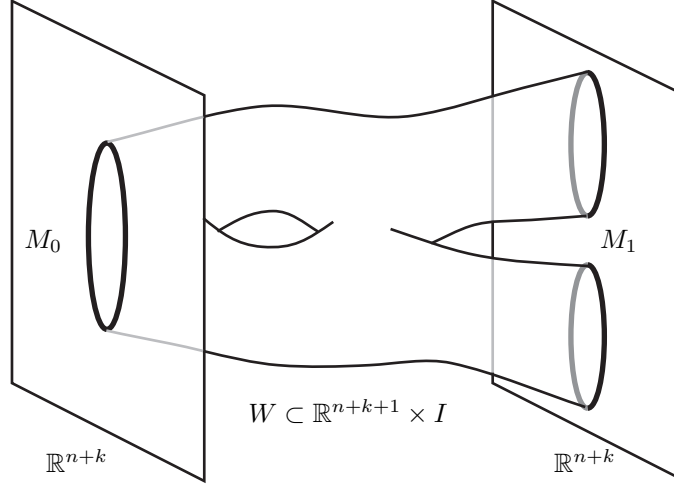

This definition is loose in the sense that we also need to specify that the boundary components of  $W$  lie entirely in  $\mathbb{R}^{n+k} \times \{0, 1\}$  and that  $W$  is transversal to this submanifold, etc., etc., etc. Looking at the picture, you get the idea. It straightforward to see that the relation imposed by bordism is an equivalence relation.

Often when you define a notion of bordism you need to specify that some boundary components have the reverse orientation, but since we consider normal  $B$ -structures rather than tangent  $B$ -structures, this is not necessary.

**Definition 5.6.** We define

$$\Omega_n^B := \{\text{closed } n\text{-manifolds w/ normal } B\text{-structure}\} / \text{bordism}$$

to be the set of equivalence classes of closed manifolds of dimension  $n$  with normal  $B$ -structure modulo bordism.

Oops! There is some dependence on  $k$  left in the definition of normal  $B$ -structure. Given an embedding  $i: M \rightarrow \mathbb{R}^{n+k}$  we can compose with the standard inclusion  $\mathbb{R}^{n+k} \rightarrow \mathbb{R}^{n+k+1}$  to obtain an embedding into  $\mathbb{R}^{n+k+1}$ . Iterating this process we obtain a sequence of embeddings

$$M \rightarrow \mathbb{R}^{n+k} \rightarrow \mathbb{R}^{n+k+1} \rightarrow \dots$$

all of which should be identified. Since the definition of  $B$ -structure involved  $\text{BO}$  and not just  $\text{BO}(k)$ , this identification is compatible with the definition.

Now  $\Omega_n^B$  is an abelian group with operation given by disjoint union and identity element  $\emptyset$ .

**Lemma 5.7.** *If  $M_0$  and  $M_1$  are closed  $n$ -manifolds with  $B$ -structures and  $M_0$  and  $M_1$  are bordant then  $\alpha(M_0) = \alpha(M_1)$ .*

*Proof.* Exercise. □

**Corollary 5.8.** *The invariant  $\alpha$  gives rise to a homomorphism of abelian groups  $\alpha: \Omega_n^B \rightarrow h^{-n}(\text{pt})$ .*

*Proof.* Exercise. □

As usual, we will extend the notation for  $\alpha$  defining it to be a homomorphism of graded abelian groups

$$\Omega_*^B = \bigoplus_{n \in \mathbb{Z}} \Omega_n^B \rightarrow h^* := \bigoplus_{n \in \mathbb{Z}} h^{-n}.$$

Let's consider the special cases of BSO and BSpin. For  $\Omega_n^{\text{BSO}}$  the traditional notation is  $\Omega_n^{\text{SO}}$  and for  $\Omega_n^{\text{BSpin}}$  the traditional notation is  $\Omega_n^{\text{Spin}}$ .

*Example 5.9.* Now

$$\alpha: \Omega_n^{\text{SO}} = \Omega_n^{\text{BSO}} \rightarrow H^{-n} = \begin{cases} \mathbb{Z} & n = 0 \\ 0 & n \neq 0 \end{cases}$$

so this is interesting only in the case  $n = 0$ . But closed 0-manifolds are just finite sets and two 0-manifolds are bordant as manifolds with normal BSO structures if and only if they have the same number of points. So the invariant  $\alpha$  simply counts the number of points.

*Example 5.10.* A closed manifold with a normal BSpin-structure is a Spin-manifold.

$$\alpha: \Omega_n^{\text{Spin}} = \Omega_n^{\text{BSpin}} \rightarrow KO^{-n} = \begin{cases} \mathbb{Z} & n \equiv 0 \pmod{4} \\ \mathbb{Z}/2\mathbb{Z} & n \equiv 1, 2 \pmod{8} \\ 0 & \text{otherwise} \end{cases}$$

In this context,  $\alpha$  is the ‘‘Atiyah invariant,’’

$$\alpha(M^{4k}) = \begin{cases} \text{index}(\mathcal{D}_M) & k \text{ even} \\ \text{index}(\mathcal{D}_M)/2 & k \text{ odd} \end{cases}$$

where  $\mathcal{D}_M$  is the Dirac operator on  $M$ . In the case of  $k$  odd, the number  $\text{index}(\mathcal{D}_M)/2$  is always an integer and also has an interpretation as the index of the Clifford linear Dirac operator.

The Atiyah invariant allows us to probe the influence of geometry and topology on one another. The following theorem is a result of this type.

**Theorem 5.11** (Lichnerowicz, Hitchin). *If  $M$  is a closed Spin-manifold with positive scalar curvature<sup>6</sup>, then  $\alpha(M) = 0$ .*

With  $\dim M = 4k$ , the case of  $k$  even was done by Lichnerowicz and the case of  $k$  odd was tackled by Hitchin. Another result in this direction is the following theorem from years ago.

**Theorem 5.12** (Stolz). *If  $M$  is a closed simply connected Spin-manifold of dimension greater than or equal to 5 then  $M$  admits a positive scalar curvature metric if and only if  $\alpha(M) = 0$ .*

A characterization of this type in dimension 4 is open. Seiberg-Witten invariants somehow play a role.

---

<sup>6</sup>Recall that positive scalar curvature means that small Riemannian balls have smaller volume than Euclidean balls.

6. REALIZATIONS OF THE  $\alpha$ -INVARIANT

Let  $M$  be a closed manifold of dimension  $n$  equipped with a normal  $h$ -orientation. Let  $\pi^M: M \rightarrow \text{pt}$  denote the projection map. Last time we showed how define a map  $\pi_!^M: h^q(M) \rightarrow h^{q-n}(\text{pt})$  which in the case of de Rham cohomology was equivalent to integration over  $M$ . This “push-forward” map goes by many names, since it was constructed in each case separately before being absorbed into this general perspective. Viewing the projection  $\pi^M: M \rightarrow \text{pt}$  as a fibration with single fiber  $M$ , this map is sometimes referred to as “integration over the fiber.” In the context of  $K$ -theory, it is known as the Gysin map. In fact, there is a more general notion of this push-forward map for a more general fibration.

Recall that if a  $B$ -structure on a vector bundle  $E$  induces an  $h$ -orientation on  $E$ , then the invariant  $\alpha$  gives rise to a group homomorphism

$$\begin{aligned} \alpha: \Omega_n^B &\rightarrow h^{-n} \\ [M] &\mapsto \alpha(M) := \pi_!^M(1) \end{aligned}$$

where  $\Omega_n^B$  is the  $n^{\text{th}}$   $B$ -bordism group and  $1 \in h^0(M)$  is the multiplicative unit.

*Example 6.1.* There are three main cases where we know that a  $B$ -structure induces an  $h$ -orientation.

- a) A BSO-structure induces a  $H$ -orientation where  $H$  is the ordinary cohomology functor. The ordinary cohomology of a point is trivial except in the degree zero where it is  $\mathbb{Z}$ . The oriented bordism group  $\Omega_0^B$  consists of bordism classes of finite sets of points and the invariant  $\alpha$  simply counts the number of points.
- b) A BSpin-structure induces a ko-orientation. Now

$$\text{ko}^{-\ell}(\text{pt}) = \begin{cases} \mathbb{Z} & \ell \geq 0 \ \& \ \ell \equiv 0 \ (4) \\ \mathbb{Z}/2\mathbb{Z} & \ell \geq 0 \ \& \ \ell \equiv 1, 2 \ (8) \\ 0 & \text{otherwise} \end{cases}$$

and  $\alpha$  is the Atiyah invariant. In the torsion-free case this give rise to the  $\hat{A}$ -genus.

- c) A BString-structure induces a tmf-orientation. I like to call the map  $\alpha: \Omega_\ell^{\text{String}} \rightarrow \text{tmf}^{-\ell}$  the Hopkins invariant. Recall from lecture 2 that we can relate  $\text{tmf}^{-\ell}$  with the modular forms  $\text{mf}^{-\ell}$  via the rational isomorphism  $\Phi$ . The composition

$$\Omega_\ell^{\text{BString}} \xrightarrow{\alpha} \text{tmf}^{-\ell} \xrightarrow{\Phi} \text{mf}^{-\ell}$$

is the Witten genus.

The  $\hat{A}$ -genus picks out the torsion free information contained in the Atiyah invariant. Much the same way, the Hopkins invariant can be viewed as a refinement of the Witten genus which includes torsion information.

**Digression on the Dirac Operator.** Let  $M$  be a closed spin manifold of dimension  $n = 4k$ . There exists a  $\mathbb{Z}/2\mathbb{Z}$ -graded complex vector bundle  $S = S^+ \oplus S^-$  called the *spinor bundle* with a first order differential operator  $\not{D}: C^\infty(S) \rightarrow C^\infty(S)$  called the *Dirac operator*. The space of sections  $C^\infty(S)$  is also  $\mathbb{Z}/2\mathbb{Z}$ -graded, and with

respect to the decomposition  $C^\infty(S) = C^\infty(S^+) \oplus C^\infty(S^-)$ , the Dirac operator has the block form

$$\mathcal{D} = \begin{pmatrix} 0 & \mathcal{D}^- \\ \mathcal{D}^+ & 0 \end{pmatrix}$$

where  $\mathcal{D}^+ = \mathcal{D}|_{S^+}$  and  $\mathcal{D}^- = \mathcal{D}|_{S^-}$ . More generally, if  $E$  is another  $\mathbb{Z}/2\mathbb{Z}$ -graded complex vector bundle with connection, then one can form the twisted Dirac operator  $\mathcal{D}_E$ , also denoted  $\mathcal{D} \otimes E$  mapping  $C^\infty(S \otimes E) \rightarrow C^\infty(S \otimes E)$ . If  $E$  is the trivial line bundle ( $E^- = 0$ ) then  $\mathcal{D}_E = \mathcal{D}$ .

The key point is the  $\mathcal{D} \otimes E$  is *elliptic* (this is an analysis notion which we will leave in a black box for the moment) and this implies that the kernel and cokernel of  $\mathcal{D}_E$  are finite-dimensional. Thus one can define

$$\text{index}(\mathcal{D}_E) = \dim(\ker \mathcal{D}_E) - \dim(\text{coker} \mathcal{D}_E).$$

Unfortunately,  $\text{coker} \mathcal{D}_E = \ker \mathcal{D}_E^\dagger = \ker \mathcal{D}_E$  since  $\mathcal{D}_E$  is self-adjoint, so  $\text{index}(\mathcal{D}_E) = 0$ .

Instead, we look at  $\text{index}(\mathcal{D}_E^+)$ . Here  $(\mathcal{D}_E^+)^\dagger = \mathcal{D}_E^-$ , so the index is not automatically zero. In fact,

$$\text{index}(\mathcal{D}_E^+) = \dim(\ker \mathcal{D}_E^+) - \dim(\ker \mathcal{D}_E^-) = \text{sdim}(\ker \mathcal{D}_E)$$

where  $\text{sdim}$  denotes the super dimension.

**Digression on Curvature.** Let  $M$  be a Riemannian manifold of dimension  $n$ . Let  $\mathbb{R}$  denote the trivial rank one bundle. The metric is a bundle map  $g$

$$\begin{array}{ccc} TM \otimes TM & \longrightarrow & \mathbb{R} \\ \downarrow & \swarrow & \\ M & & \end{array}$$

satisfying conditions of symmetry and positive definiteness. The Riemann curvature tensor is a bundle map  $R$

$$\begin{array}{ccc} TM \otimes TM \otimes TM & \longrightarrow & TM \\ \downarrow & \swarrow & \\ M & & \end{array}$$

defined using the Levi-Cevita connection on  $M$ . The Ricci curvature is a bundle map  $\text{Ric}$

$$\begin{array}{ccc} TM \otimes TM & \longrightarrow & \mathbb{R} \\ \downarrow & \swarrow & \\ M & & \end{array}$$

defined by  $\text{Ric}(v, w) = \sum_{j=1}^n g(R(v, e_j)w, e_j)$  where  $\{e_1, \dots, e_n\}$  is an orthonormal basis of  $T_m M$ . Due to the symmetries of the Riemann curvature tensor,  $\text{Ric}$  is a symmetric bilinear form. Finally, the scalar curvature  $s \in C^\infty(M)$  is the smooth function defined by  $s(m) = \sum_{j=1}^n \text{Ric}(e_j, e_j)$  where  $\{e_1, \dots, e_n\}$  is an orthonormal basis for  $T_m M$ .

Having positive scalar curvature means that Riemannian balls in  $M$  have smaller volume than balls of the same radius in Euclidean space. Interpreting the Ricci curvature is more complicated. One could hope that in a normal ball about  $m \in M$ ,

the Riemannian volume form pulls-back via the exponential map to the linear volume form on  $T_m M$ . Of course, this is too much to hope for as there is distortion, but the pull-back is related to the linear volume by a density function. The first interesting term in the Taylor expansion about 0 is quadratic and is equal to the Ricci tensor. In this sense, the Ricci tensor measures the volume distortion of the exponential map.

**Theorem 6.2** (Lichnerowicz). *If  $M$  is a closed spin manifold of dimension  $4k$  with positive scalar curvature, then  $\hat{A}(M) = 0$ .*

*Proof.* By the index theorem,  $\hat{A}(M) = \text{index}(\mathcal{D}_M^+)$ . The Weitzenböck formula shows that  $\mathcal{D}^2 = \Delta + \frac{1}{4}s: C^\infty(S) \rightarrow C^\infty(S)$  where  $\Delta$  is the rough Laplacian (also known as the Bochner Laplacian). The spinor bundle has a natural Hermitian inner product and the rough Laplacian is a self-adjoint non-negative operator. Since  $s > 0$  and the manifold is closed, the spectrum of  $\Delta + \frac{1}{4}s$  is bounded away from zero. Thus  $\ker \mathcal{D}^2 = 0$  which implies  $\ker \mathcal{D} = 0$  and thus  $\text{sdim } \ker \mathcal{D} = \text{index}(\mathcal{D}^+) = 0$ .  $\square$

An interesting consequence of this is the following. The manifold  $\mathbb{C}P^2$  with its standard Kähler metric has positive sectional curvature and thus has positive scalar curvature. However,  $\hat{A}(\mathbb{C}P^2) = -1/8$ , so  $\mathbb{C}P^2$  is *not* spin.

We will finish today with the definition of the Witten genus. Here it is:

**Definition 6.3.** Let  $M$  be a closed spin manifold of dimension  $n = 4k$ . The *Witten genus*  $W(M) \in \mathbb{Z}[[q]]$  is defined as follows

$$(6.1) \quad W(M) := \text{index} \left( \mathcal{D}_M^+ \otimes \bigotimes_{m=1}^{\infty} S_{q^m}(TM_{\mathbb{C}} - \underline{n}) \right).$$

Clearly, we need to unwind the notation here to understand what this even means. Now  $W(M)$  is a power series in  $q$  with integer coefficients, so the right side of (6.1) needs to be interpreted as a power series.

First of all,  $TM_{\mathbb{C}}$  denotes the complexified tangent bundle of  $M$  and the trivial bundle of rank  $n$  over  $M$  is what is meant by  $\underline{n}$ . Thus  $TM_{\mathbb{C}} - \underline{n}$  is a virtual vector bundle. Given a complex vector bundle  $E \rightarrow M$ , one can form the symmetric powers  $S^k E \rightarrow M$  for each  $k$ . The *total symmetric power* is the formal power series

$$S_t(E) := \sum_{k=0}^{\infty} (S^k E) t^k = \underline{\mathbb{C}} + Et + S^2 E t^2 + \dots \in \text{Vect}(M)[[t]]$$

where the trivial complex line bundle is denoted  $\underline{\mathbb{C}}$ . The total symmetric power has the exponential property  $S_t(E \oplus F) = S_t(E) \otimes S_t(F)$ . So we define  $S_t(E - F) := S_t(E) S_t(F)^{-1}$  where  $S_t(F)^{-1}$  is the power series obtained by formally inverting the power series  $S_t(F)$ . All told then, the Witten genus of  $M$  is a power series in  $q$  whose coefficients are indices of twisted Dirac operators. The operators act in the various vector bundles occurring as coefficients in the specified series.

The constant term is  $a_0 = \text{index}(\mathcal{D}_M^+)$  and the linear coefficient is

$$a_1 = \text{index}(\mathcal{D}_M^+ \otimes (TM_{\mathbb{C}} - \underline{n})).$$

The idea is to interpret  $TM_{\mathbb{C}} - \underline{n}$  as  $\mathbb{Z}/2\mathbb{Z}$ -graded vector bundle  $E$  with  $E^+ = TM_{\mathbb{C}}$  and  $E^- = \underline{n}$ . In general,  $a_k$  is the index of some twisted Dirac operator  $\mathcal{D}_M^+ \otimes V_k$  where  $V_k$  is a  $\mathbb{Z}/2\mathbb{Z}$ -graded vector bundle built from the symmetric powers of  $TM_{\mathbb{C}}$  and  $\underline{n}$ .

**Theorem 6.4** (Zagier). *If  $M$  is a string manifold of dimension  $n$  then the Witten genus is the  $q$ -expansion of an integral modular form of weight  $n/2$ .*

This theorem has a remarkable consequence, namely that the coefficients of  $W(M) = a_0 + a_1q + a_2q^2 + \dots$  must be entirely determined by the first few. For example, if the dimension of  $M$  is smaller than 24, then  $W(M) \in M_{n/2} \subset M_* = \mathbb{C}[c_4, c_6]$ , so  $M_{n/2}$  has dimension less than or equal to 1 for  $n/2 < 12$  or, equivalently,  $n < 24$ . Thus  $W(M)$  is entirely determined by  $a_0 \in \mathbb{Z}$ .

## 7. A MOTIVATING CONJECTURE

Last time we discussed the Witten genus. Heuristically, this integral modular form can be thought of as the  $S^1$ -equivariant index of the Dirac operator on the free loop space of a manifold. It is known how to construct a spinor bundle on the free loop space of a manifold but an appropriate notion of the Dirac operator is not available in general ( $\mathcal{D}$  has a representation theoretic construction in the case of the loop space of a homogeneous space). Pushing ahead anyway, the Dirac operator would commute with the circle action on the loop space, so the kernel and cokernel would be representations of  $S^1$  which we could decompose into irreducible components indexed by the natural numbers. The difference of the dimensions of the corresponding components of the kernel and cokernel labeled by  $n$  we put as the  $n^{\text{th}}$  coefficient in a power series in  $q$ . There are heuristic arguments that establish that this  $q$ -series is the Witten genus.

Let us also remark that one can perform the same yoga with the Euler characteristic operator and the signature operator, obtaining similar formulas for the Witten genus but involving twists of the given operator on  $M$  by symmetric and exterior powers.

Today, we would like to compare and contrast the Hopkins invariant with the Atiyah invariant. Recall that the Hopkins invariant is a surjective ring homomorphism from the string bordism category  $\Omega_*^{\text{String}}$  to  $\text{tmf}^{-*}$ . By composing with the rational isomorphism  $\Phi: \text{tmf}^{-*} \rightarrow \text{mf}^{-*}$  we lose the torsion information in the Hopkins invariant yet we obtain an integral modular form. The composition

$$\begin{array}{ccccc} \Omega_*^{\text{String}} & \xrightarrow{\alpha} & \text{tmf}^{-*} & \xrightarrow{\Phi} & \text{mf}^{-*} \\ & \searrow W & & & \downarrow \\ & & & & \mathbb{Z}[[q]] \end{array}$$

is the Witten genus  $W$ .

There is an analogous picture in  $\text{ko}$ -theory. By Bott periodicity, we need only specify the coefficient groups<sup>7</sup> of  $\text{ko}$  for  $-n = 0, 1, \dots, 8$ . Each one is cyclic and the table below shows these groups together with their generators.

$n$	0	1	2	3	4	5	6	7	8
$\text{ko}^{-n}$	$\mathbb{Z}$	$\mathbb{Z}/2\mathbb{Z}$	$\mathbb{Z}/2\mathbb{Z}$	0	$\mathbb{Z}$	0	0	0	$\mathbb{Z}$
gen	1	$\eta$	$\eta^2$		$\omega$				$\mu$

<sup>7</sup>One can interpret the groups  $\text{ko}^{-n}$  as Grothendieck enveloping groups of modules over Clifford algebras.

The element  $\mu$  is the Bott-periodicity element. The generator  $\eta$  corresponds to important class by the same name in the stable homotopy of spheres. As a ring  $\mathrm{ko}^{-*} = \mathbb{Z}[\eta, \omega, \mu]/(2\eta, \eta^3, \omega\eta, \omega^2 - 4\mu)$  and if we consider  $\frac{\omega}{2}$  as a formal symbol, we can define a rational isomorphism  $\Phi: \mathrm{ko}^{-*} \rightarrow \mathbb{Z}[\frac{\omega}{2}]$  by the assignments  $\eta \mapsto 0$ ,  $\omega \mapsto 2(\frac{\omega}{2})$ , and  $\mu \mapsto (\frac{\omega}{2})^2$ . The composition of the Atiyah invariant with this map  $\Phi$  is the  $\hat{A}$ -genus.

$$\Omega_*^{\mathrm{Spin}} \longrightarrow \mathrm{ko}^{-*} = \mathbb{Z}[\eta, \omega, \mu]/(2\eta, \eta^3, \omega\eta, \omega^2 - 4\mu) \longrightarrow \mathbb{Z}[\frac{\omega}{2}]$$

The value of  $\alpha(M)$  is 0 unless  $[M]$  is the bordism class of a manifold of dimension  $4k$ . In that case  $\Phi(\alpha([M])) = \hat{A} \cdot (\frac{\omega}{2})^k$ . When  $k = 2\ell + 1$  this needs some interpretation. By the relations in  $\mathrm{ko}^{-*}$  the element  $(\frac{\omega}{2})^2$  is equivalent to the Bott periodicity element  $\mu$ . Thus  $(\frac{\omega}{2})^k$  can be identified with  $(\frac{\omega}{2})\mu^\ell$ , but this element is not in the image of  $\Phi$ . However,  $2(\frac{\omega}{2})\mu^\ell$  is the image, so we must interpret  $\alpha([M]) = \hat{A}(M)(\frac{\omega}{2})^{2\ell+1}$  as  $\frac{\hat{A}(M)}{2} \cdot 2(\frac{\omega}{2})\mu^\ell$ . Fortunately for us, the  $\hat{A}$ -genus of a spin manifold of dimension congruent to 4 modulo 8 is always divisible by 2. This has to do with the relation between Clifford algebras and the Hamiltonian quaternions  $\mathbb{H}$  in dimensions congruent to 4 modulo 8.

The following conjecture is what motivated our study of this subject.

**Conjecture 7.1** (Höhn, Stolz '94). *If  $M$  is a string manifold of dimension  $4k$  with positive Ricci curvature, then  $W(M) = 0$ .*

Previously we gave an interpretation of positive scalar curvature, namely that the exponential map contracts the volume of a small Euclidean ball about the origin in the tangent space when mapping it to a Riemannian ball in the manifold. Having positive Ricci curvature means that volumes contract under the exponential map for every small shape about the origin, not just a small ball.

Here is some evidence for the conjecture:

- a) This is true for  $n < 24$  because in that case the Witten genus is determined by its constant term  $a_0$ . Having positive Ricci curvature implies that the manifold has positive scalar curvature and the Lichnerowicz argument can be made to show that  $a_0 = 0$ .
- b) It is true for compact semi-simple Lie groups. The bi-invariant metric has positive Ricci curvature and the Witten genus vanishes.
- c) It is also true for homogeneous spaces of such groups.
- d) If  $M$  is a complete intersection in  $\mathbb{C}P^{n/2+k}$ , the conjecture also holds.

The idea was to apply the Lichnerowicz strategy to argue about  $\not{D}_{\mathcal{L}M}$ . Heuristically, the scalar curvature of  $\mathcal{L}M$  might be the integral of the contraction of  $\mathrm{Ric}_M$  with the tangent vector to the loop. Unfortunately, this does not quite work due to analytical difficulties, but it hints as to how the Ricci curvature on  $M$  might be connected with the scalar curvature of  $\mathcal{L}M$ . There does exist a Weitzenböck formula for twisted Dirac operators  $\not{D}_M \otimes E$ . The hope is that one can use positivity of the Ricci curvature on  $M$  to prove that all of the twisted Dirac operators  $\not{D}_M \otimes E_i$  arising in the definition of the Witten genus are invertible using the Lichnerowicz argument.

Unfortunately, if one could argue this way, one would prove too much. The argument would not use the string structure in any way. It is known that the Witten genus of  $\mathbb{H}P^2$  is non-zero, but on the other hand  $\mathbb{H}P^2$  has positive Ricci

curvature and is a homogeneous space of the symplectic group. Thus  $\mathbb{H}P^2$  is not a string manifold. What is needed is a translation of the string condition into a more concrete statement about the manifold  $M$ .

In search of such a condition, our story now turns to quantum field theory. There are at least three ways to think about quantum field theory from a mathematical perspective. We roughly enumerate these as follows:

- (1) Atiyah-Segal axioms
- (2) Constructive/Algebraic Quantum Field Theory (Wightman, Osterwalder-Schrader, Glimm-Jaffe)
- (3) Vertex Operator Algebras (VOAs) (Borchers, Lepowski, Kac)

The first is most closely aligned with algebraic topology. The second is analytical and third is algebraic. The third discussion significantly weakens the required properties but has the advantage of offering many examples from algebra. The second is more broad, but also technically more challenging. The first is in some ways the most general but also the realm in which we are farthest from constructing examples (although there has been some recent work in this direction by Pickrell).

## 8. PRELIMINARY DEFINITION OF FIELD THEORIES

The  $\mathbb{Z}/2\mathbb{Z}$ -graded topological vector spaces form the objects of a category  $\mathcal{TV}$  whose morphisms are continuous linear maps of graded vector spaces. Given  $V \in \mathcal{TV}$ , write  $\epsilon_V: V \rightarrow V$  for the grading involution. The  $+1$  eigenspace of  $\epsilon_V$  is called the *even part of  $V$*  and is denoted  $V^{\text{even}}$  or  $V^+$  interchangeably. Similarly, the  $-1$  eigenspace is called the *odd part of  $V$*  and is denoted  $V^{\text{odd}}$  or  $V^-$ .

The category  $\mathcal{TV}$  is a monoidal category with monoidal structure given by the completed *projective* tensor product  $\otimes$ . Given  $V, W \in \mathcal{TV}$ , the grading involution associated to  $V \otimes W$  is  $\epsilon_V \otimes \epsilon_W$ . The category is also braided with braiding isomorphism  $\tau: V \otimes W \rightarrow W \otimes V$  linearly determined by its value on homogeneous elements by  $v \otimes w \mapsto (-1)^{|v||w|} w \otimes v$  where  $|v| \in \{0, 1\}$  is the degree of the homogeneous element  $v \in V$ , i.e.,  $|v| = 0$  if  $v \in V^{\text{even}}$  and  $|v| = 1$  if  $v \in V^{\text{odd}}$ . With this braiding,  $\mathcal{TV}$  is also a symmetric monoidal category since the diagram

$$\begin{array}{ccc}
 V \otimes W & \xrightarrow{\text{id}} & V \otimes W \\
 & \searrow \tau & \nearrow \tau \\
 & W \otimes V &
 \end{array}$$

commutes.

In general, the monoidal structure  $\otimes$  of a monoidal category  $\mathcal{C}$  is symmetric if there exists an invertible natural transformation  $T$  with  $T^2 = \text{id}$  relating the functors  $\otimes$  and  $\otimes$  precomposed with interchange of arguments.

The forgetful functor from  $\mathcal{TV}$  to the semi-category of topological vector spaces is a symmetric monoidal functor. Those  $\mathbb{Z}/2\mathbb{Z}$ -graded vector spaces which are entirely even also form a full sub-category of  $\mathcal{TV}$ .

Temporarily, we denote by  $d$ -RB the category whose objects are  $d - 1$  dimensional closed oriented manifolds and whose morphisms are  $d$ -dimensional oriented Riemannian bordisms modulo orientation-preserving isometry. Given an object  $Y \in d$ -RB, we write  $\bar{Y}$  for same  $(d - 1)$ -manifold but with the opposite orientation. Disjoint union gives this category a monoidal structure (almost).

Here is a rough definition of field theories.

**Definition 8.1** (Rough). A *Riemannian field theory (RFT)* of dimension  $d$  is a symmetric monoidal functor

$$d\text{-RB} \xrightarrow{E} \text{TV} .$$

Such a functor will be referred to as a  $d$ -RFT.

Here is a picture that we will often draw to keep track of the ingredients involved. We read the bordism from right to left. Note that  $\partial\Sigma = Y_1 \amalg \bar{Y}_0$ , so we think of  $Y_0$  as incoming and  $Y_1$  as outgoing.

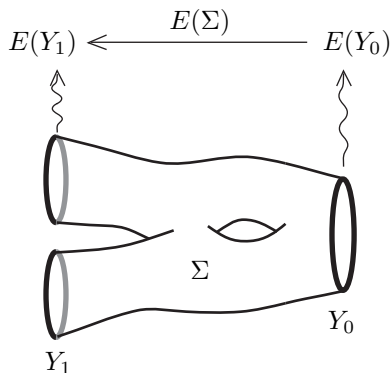

Now, why were we careful to say that the definition above is a “rough” definition? Here are some issues that will need to be resolved later.

- As defined  $d$ -RB does not have identities. So in particular there is no notion of isomorphism and no well-defined monoidal structure of interest.
- Ultimately, we want  $E$  to be a smooth functor, that is to say it will be important to work in families.

There are also a number of variations on this theme that are possible. For example, one could replace Riemannian metrics by other geometric structures.

- If one uses bordisms which are flat Riemannian manifolds, the bordism category is denoted  $d$ -EB, and a symmetric monoidal functor from  $d$ -EB to TV is called a Euclidean field theory (EFT).
- Bordisms with conformal structure gives the category  $d$ -CB and a symmetric monoidal functor to TV is a conformal field theory (CFT).
- If the bordisms are simply oriented smooth manifolds then the bordism category is denoted  $d$ -B and a symmetric monoidal functor to TV is called a topological field theory (TFT).
- If one keeps the Riemannian structure on bordisms but replaces orientation by spin structure, the category is denoted  $d$ -RB<sup>Spin</sup> and a symmetric monoidal functor to TV is called a Riemannian Spin field theory ( $d$ -RFT<sup>Spin</sup>).
- One could also replace the  $(d - 1)$ -manifold  $Y$  with a super manifold of dimension  $(d - 1)|\delta$ , the bordisms  $\Sigma$  by super manifolds of dimension  $d|\delta$ , and the Euclidean structure by a super Euclidean structure.

With this last modification, one obtains a symmetric monoidal bordism category  $d|\delta - \text{EB}$ .

**Definition 8.2** (Rough). A  $d|\delta$ -dimensional (*supersymmetric*) *Euclidean field theory* ( $d|\delta$ -EFT) of dimension  $d|\delta$  is a symmetric monoidal functor  $d|\delta - \text{EB} \rightarrow \text{TV}$ .

Note that  $d|0\text{-EB} = d\text{-EB}$ . We will discuss this later, but let us point out that the requirement that bordisms have a super Euclidean structure constrains the possible values of  $\delta$  to depend on  $d$ . Now it turns out that from a Euclidean spin field theory it is possible to construct a  $d|\delta\text{-EFT}$  through a functorial process called “superfication.” Denoting this functor by  $S$ , we see that pre-composition with  $S$

$$\begin{array}{ccc} d\text{-EB} & \xrightarrow{E \circ S} & \text{TV} \\ & \searrow S & \nearrow E \\ & d|\delta\text{-EB} & \end{array}$$

yields a  $d$ -dimensional Euclidean spin field theory from a  $d|\delta$ -dimensional EFT  $E$ . As another remark, we mention that if one does not want to work in families, this turns out to be an equivalence of categories, but in families this is not the case. This distinction is responsible for the interest in much of our later discussion.

An additional variation is to consider *field theories over  $X$*  where  $X$  is a smooth manifold. We replace the objects  $Y$  by pairs  $(Y, f: Y \rightarrow X)$  where  $f$  is a smooth map to  $X$ , and we replace bordisms  $\Sigma$  with pairs  $(\Sigma, F: \Sigma \rightarrow X)$  where  $F$  restricts on the boundary to the maps there. This bordism category is denoted  $d|\delta\text{-EB}(X)$ .

**Definition 8.3** (Rough). A  $d|\delta$ -dimensional Euclidean field theory over  $X$  ( $d|\delta\text{-EFT over } X$ ) is a symmetric monoidal functor  $d|\delta\text{-EB}(X) \rightarrow \text{TV}$ .

From a mathematical perspective it useful to think of a field theory over  $X$  as a family of Euclidean field theories parameterized by  $X$ .

The nice thing about field theories over  $X$  is that they pull-back. Given a smooth map  $\phi: X_1 \rightarrow X_2$ , post-composition with  $\phi$  gives a symmetric monoidal functor  $\phi_*$  and its composition with an EFT over  $X_2$  gives an EFT  $\phi^*E$  over  $X$ .

$$\begin{array}{ccc} d|\delta\text{-EB}(X) & \xrightarrow{\phi^*E} & \text{TV} \\ & \searrow \phi_* & \nearrow E \\ & d|\delta\text{-EB}(Y) & \end{array}$$

**Definition 8.4** (Rough). By  $d|\delta\text{-EFT}(X)$  we denote the category of all  $d|\delta\text{-EFT's over } X$ . The objects of this category are  $d|\delta\text{-EFT's over } X$  and the morphisms are invertible natural transformations between such functors.

Since our goal in considering these objects was get a hold of topological information, we now need a way to forget the geometric structure while retaining the essential structure. Adopting a similar term from differential topology we make the following definition.

**Definition 8.5.**  $E_0, E_1 \in d|\delta\text{-EFT}(X)$  are *concordant* if there exists  $E \in d|\delta\text{-EFT}(X \times \mathbb{R})$  such that  $\iota_0^*E \simeq E_0$  and  $\iota_1^*E \simeq E_1$  where  $\iota_\ell: X \rightarrow X \times \mathbb{R}$  is given by  $x \mapsto (x, \ell)$  for  $\ell = 0, 1$ .

The set of concordance classes of  $d|\delta\text{-EFT's over } X$  is denoted  $d|\delta\text{-EFT}[X]$ .

## 9. EXAMPLES

Recall that a  $d|\delta\text{-EFT over a manifold } X$  is a symmetric monoidal functor  $E: d|\delta\text{-EB}(X) \rightarrow \text{TV}$ . We think of such an object mathematically as a family of EFT's

parameterized by  $X$ . Given a smooth map  $\phi: X_1 \rightarrow X_2$  we get a symmetric monoidal functor  $\phi^*: d|\delta\text{-EFT}(X_2) \rightarrow d|\delta\text{-EFT}(X_1)$ . In particular, given a point  $x \in X$ , we have the inclusion map  $\text{pt} \rightarrow X$  so  $E \in d|\delta\text{-EFT}(X)$  pulls back to  $x^*E \in d|\delta\text{-EFT}(\text{pt})$ . This later category we denote more briefly by simply  $d|\delta\text{-EFT}$ .

There is a further generalization which we may discuss later, namely  $d|\delta\text{-EFT}'s$  over  $X$  of degree  $n$ . These form a category denoted  $d|\delta\text{-EFT}^n(X)$  which is also well behaved under pull-back. By  $d|\delta\text{-EFT}^n[X]$  we denote the set of concordance classes of  $d|\delta\text{-EFT}'s$  over  $X$  of degree  $n$ .

There is a functor  $d|\delta\text{-EFT}^n(X) \rightarrow d\text{-EFT}^n(X)^{\text{Spin}}$ . For now, we will describe this only in degree  $n = 0$ . In this context it is merely the pre-composition with the appropriate superification functor  $d\text{-EB}(X)^{\text{Spin}} \rightarrow d|\delta\text{-EB}(X)$ . The result is to basically forget about the super symmetry.

Let us consider some examples.

*Example 9.1.* Let  $M$  be a closed Riemannian manifold of dimension  $n$ . Here is an example of a 1-EFT cooked up from  $M$ . The objects of 1-EB are  $\text{pt}$  and  $\overline{\text{pt}}$ . To  $\text{pt}$  we associated the vector space  $C^\infty(M)$  equipped with the Frechet topology. To the interval  $I_t = [0, t]$  we associate the heat operator  $e^{-t\Delta}$  where  $\Delta$  denotes the non-negative Laplace-Beltrami operator on  $M$ . From the physics point of view this EFT is the (Wick rotated) quantization of a point particle moving in  $M$ .

*Example 9.2.* Now suppose that  $\dim(M) = 4k$  and that  $M$  is also a spin manifold so that we have a Dirac operator  $\mathcal{D}_M$ . By  $\overline{E}_M$  we will denote the following EFT. To  $\text{pt}$  we associate the space of spinors on  $M$  and to the interval  $I_t$  we assign the operator  $e^{-t\mathcal{D}_M^2}$ .

Many modifications of both of these examples are possible. For example, one could replace  $\mathcal{D}_M^2$  by that plus a potential, or replace  $\Delta$  by  $\Delta$  plus a potential.

The reason the second example is of sufficient interest to warrant its own notation is that it can be extended to a supersymmetric EFT denoted  $E_M \in 1|1\text{-EFT}$ . This is due to the fact that  $\mathcal{D}_M^2$  is the square of an odd operator. The field theory  $E_M$  is the quantization of a super particle moving in  $M$ . With this, the 1-EFT obtained by forgetting the super symmetry is  $\overline{E}_M$ . It is also possible to use the Clifford linear Dirac operator to construct  $E_M \in 1|1\text{-EFT}^{-n}$ .

*Example 9.3 (Family version).* Now suppose that  $M$  is a fiber bundle over  $X$  with spin fibers, i.e. the vertical bundle over  $M$  is spin. We will now define  $\overline{E}_M: 1\text{-EB}(X) \rightarrow \text{TV}$  as follows. To  $\text{pt}$  together with a map  $x: \text{pt} \rightarrow X$  we assign the space of spinors on the fiber  $M_x$ . To the interval  $I_t$  together with a *constant* map to  $X$  we associate the operator  $e^{-t\mathcal{D}_{M_x}^2}$  acting in the space of spinors over the fiber  $M_x$ . This operation can be represented as integration against a kernel function and via the work of Bruce Driver and this kernel can be represented by a path integral. For the interval together with a more general map to  $X$ , we use a path integral representation to define the operator, but more on that later.

Again, by using the Clifford linear Dirac operator instead one can construct  $E_M \in 1|1\text{-EFT}^n(X)$ . The following table lists what we know about these theories, their geometric realizations, and their concordance classes in low dimensions.

$d \delta$	$d \delta\text{-EFT}^n(X)$	$d \delta\text{-EFT}^n[X]$
0 0	$C^\infty(X)$	0
0 1	$\Omega_{\text{closed}}^{\text{even}}(X)$ for $n$ even $\Omega_{\text{closed}}^{\text{odd}}(X)$ for $n$ odd	$H_{\text{dR}}^{\text{even}}(X)$ $H_{\text{dR}}^{\text{odd}}(X)$
1 1	$n = 0$ contains category of V.B.'s with connection.	$K^n(X)$
2 1	?	Conjecture: $\text{TMF}^n(X)$

The second row is the result of work of Hohnhold-Kreck-Stolz-Teichner. That concordance classes of 1|1-EFT's of degree  $n$  over  $X$  gives  $K^n$  of  $X$  is a theorem of Stolz-Teichner. One can obtain real or complex  $K$ -theory here depending on the base field taken in TV. The partial geometric characterization of 1|1-EFT's of degree 0 as being like vector bundles with connection is work of Florin Dumitrescu.

The right hand column of this table is a natural progression in topology. The notion of complex orientable cohomology theories are related to formal groups. The additive formal group law corresponds to the de Rham cohomology theory. The next level of complexity is the multiplicative formal group law and that corresponds to  $K$ -theory. After that is the formal group of elliptic curves which corresponds to TMF.

As one final comment for today, we would like to mention that, in a certain sense, field theories give a conceptual explanation of the Chern character which relates  $K$ -theory with the  $H_{\text{dR}}^{\text{even}}(X)$ . From a 1|1-EFT over  $X$ ,  $E: 1|1\text{-EB}(X) \rightarrow \text{TV}$ , we can produce a 0|1-EFT over  $X$  by taking the product with  $S^1$ . More precisely, we define a map  $\times S^1: 0|1\text{-EB}(X) \rightarrow 1|1\text{-EB}(X)$  by sending  $\Sigma^{0|1} \rightarrow X$  to the composition  $\Sigma^{0|1} \times S^1 \rightarrow \Sigma \rightarrow X$  where in the first step we project on the first factor.

This gives a diagram

$$\begin{array}{ccc}
 K^0(X) & \xrightarrow{Ch} & H^{\text{even}}(X) \\
 \downarrow & & \downarrow \\
 1|1\text{-EFT}[X] & \xrightarrow{\times S^1} & 0|1\text{-EFT}[X]
 \end{array}$$

where the vertical arrows are isomorphisms. Matthias Kreck conjectured that this diagram commutes and this was proven in the affirmative by Fei-Han.

## 10. PARTITION FUNCTIONS AND PHYSICS MOTIVATIONS

Recall from last time our main conjecture.

**Conjecture 10.1.**  $2|1\text{-EFT}^n[X] \simeq \text{TMF}^n(X)$ .

To prove this conjecture, we would like to establish that concordance classes of 2|1 dimensional Euclidean field theories give a generalized cohomology theory, in the sense that they satisfy the Eilenberg-Steenrod axioms. Then, one would need only to compare the coefficients of the theory with those of TMF, but this has so far proved difficult.

Our goal today is to offer some evidence for this conjecture. To do that we will need to discuss partition functions. Recall that there is a reduction process by which one obtains  $\bar{E} \in 2\text{-EFT}$  from  $E \in 2|1\text{-EFT}$  by forgetting the super symmetry. We defined the partition function of  $E$  to be the partition function of  $\bar{E}$ .

**Definition 10.2.** The *partition function* of  $\bar{E} \in 2\text{-EFT}$  is the function  $Z_{\bar{E}}: \mathfrak{h} \rightarrow \mathbb{C}$  whose value on  $\tau \in \mathfrak{h}$  is the value of  $\bar{E}$  on the torus  $\mathbb{C}/(\mathbb{Z} + \tau\mathbb{Z})$ .

Perhaps that requires some brief explanation. Since the torus is a closed manifold, we are to regard it as a bordism of the empty set with itself. The functor  $\bar{E}$  thus assigns to such a bordism an endomorphism of the vector space assigned to the empty set. But since the empty set is a monoidal unit and  $\bar{E}$  is a monoidal functor, the vector space is canonically  $\mathbb{C}$  and such an operator is multiplication by a particular number. This number is the value of  $Z_{\bar{E}}(\mathbb{C}/(\mathbb{Z} + \tau\mathbb{Z}))$ . Since we built into the definition that  $\bar{E}$  is a smooth functor this turns out to imply that  $Z_{\bar{E}}$  is a smooth function on  $\mathfrak{h}$ , but not necessarily holomorphic.

In two dimensions, the only flat closed manifolds are tori. The moduli space of flat tori (up to isometry) is larger than  $\mathfrak{h}$ , strictly speaking  $\mathfrak{h} \times \mathbb{R}_{>0}$ . So we are ignoring some information here. What are the modularity properties of  $Z_{\bar{E}}$ ? Suppose

$$\tau' = \frac{a\tau + b}{c\tau + d} \text{ for some } \begin{pmatrix} a & b \\ c & d \end{pmatrix} \in \text{SL}(2, \mathbb{Z})$$

then it is a good exercise to check that the map

$$\begin{aligned} \mathbb{C}/(\mathbb{Z} + \tau'\mathbb{Z}) &\rightarrow \mathbb{C}/(\mathbb{Z} + \tau\mathbb{Z}) \\ [\zeta] &\mapsto [(c\tau + d)\zeta] \end{aligned}$$

is a diffeomorphism and a conformal equivalence. It is an isometry if and only if  $|c\tau + d| = 1$ .

If  $\bar{E}$  were a CFT then we would have automatically that  $\bar{E}(\mathbb{C}/(\mathbb{Z} + \tau'\mathbb{Z})) = \bar{E}(\mathbb{C}/(\mathbb{Z} + \tau\mathbb{Z}))$  but for an EFT we do not expect  $\text{SL}(2, \mathbb{Z})$ -invariance. However we do have the following very interesting result.

**Theorem 10.3** (Stolz-Teichner). *If  $\bar{E}$  is the reduction of  $E \in 2|1\text{-EFT}^n$  then  $Z_E$  is a weakly holomorphic integral modular form of degree  $n$ .*

The following diagram shows how the mathematical and physical viewpoints on these subjects line up.

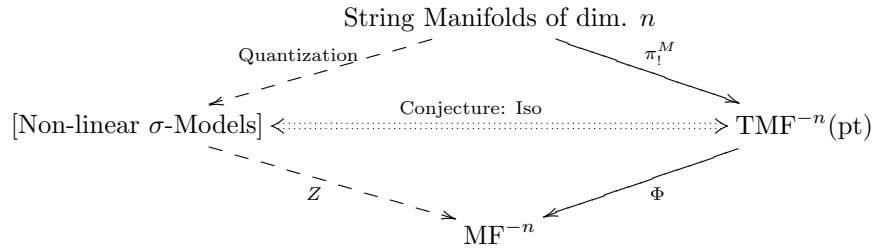

The right hand side lives in the mathematical realm. Given a closed string manifold of dimension  $n$  we can use the push-forward map  $\pi_1^M$  associated to the projection  $\pi: M \rightarrow \text{pt}$  to compute the Hopkins invariant  $\alpha(M) = \pi_1^M(1) \in \text{TMF}^{-n}(\text{pt})$ . Using the map  $\Phi$ , which is a rational isomorphism, we can eliminate the torsion information and obtain the modular form of degree  $-n$ , the Witten genus  $W(M)$ . The way Witten came to his definition of this genus however was through the left hand side of the diagram. Given a closed string manifold of dimension  $n$ , one should quantize 1|1-dimensional super strings moving in  $M$  to obtain the super symmetric non-linear sigma model of  $M$ . Let us denote this by  $\sigma_2(M)$ . As yet,

this is not well-defined as a mathematical object, but we believe that it gives a 2|1-EFT of degree  $-n$ . By computing the partition function  $Z_{\sigma_2(M)}$  (a path integral) one obtains a modular form of degree  $-n$ , which is again the Witten genus, i.e.,  $Z_{\sigma_2(M)} = \Phi(\pi_1^M(1))$ . If non-linear sigma models can be constructed as 2|1-EFT's, then we can understand the partition function in our previous sense, making that leg of the diagram well-defined. Our conjecture states that  $2|1\text{-EFT}^{-n}[\text{pt}]$  is isomorphic to  $\text{TMF}^{-n}(\text{pt})$  and this can be implemented by an isomorphism which makes this diagram commute.

Here is a generalized version of this diagram to the family setting.

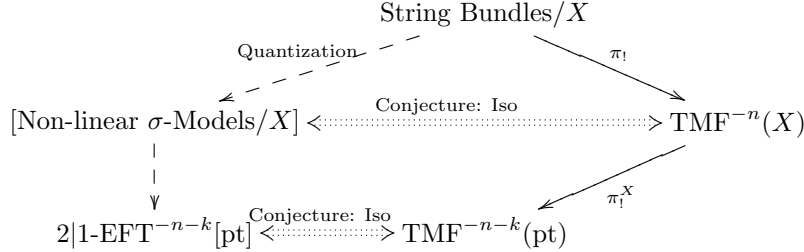

Suppose that  $F \rightarrow M \xrightarrow{\pi} X$  is a fiber bundle of dimension  $n+k$  with  $n$ -dimensional string manifold fibers modeled on  $F$ . In particular,  $M$  is then a string manifold of dimension  $n+k$ . Mathematically, we can construct  $\pi_1(1) \in \text{TMF}^{-n}(X)$ . Since the push-forward map from  $M$  factors as  $\pi_1^M = \pi_1^X \circ \pi_1$ , we can then apply  $\pi_1^X$  to obtain the element  $\pi_1^M(1) \in \text{TMF}^{-n-k}(\text{pt})$ . On the other hand, via physics one writes down a non-linear sigma model over  $X$ , which we denote  $\sigma_2(M/X)$ . This should be a 2|1-EFT $^{-n}$  over  $X$ , and physically one should think of the base space  $X$  as the space of parameters of the model. By some process, one should be able to obtain a 2|1-EFT $^{-n}$  over a point. The family version of our conjecture is that there is an isomorphism between concordance classes of 2|1-EFT $^{-n}$  over  $X$  and  $\text{TMF}^{-n}(X)$ .

Now let's discuss one dimensional EFT's. The functor  $\bar{E} \in 1\text{-EFT}$  assigns to a point a  $\mathbb{Z}/2\mathbb{Z}$ -graded vector space  $\bar{E}(\text{pt})$  and to the interval  $I_t = [0, t]$  and operator  $\bar{E}(I_t): \bar{E}(\text{pt}) \rightarrow \bar{E}(\text{pt})$ . Due to the fact that the bordisms  $I_t$  form a semi-group with respect to the monoidal structure in the bordism category 1-EB, operators assigned to the intervals  $I_t$  must form a continuous semi-group of operators on  $\bar{E}(\text{pt})$ . Furthermore they must be trace class and so must be of the form  $e^{-tA}$  for some operator  $A$ . The trace class condition puts restrictions on the spectral properties of this operator, but we will ignore this for now.

Now if  $\bar{E}$  is the reduction of  $E \in 1|1\text{-EFT}$ , then  $A$  is necessarily the square of an odd operator  $D$  acting in  $\bar{E}(\text{pt})$ . It turns out that the functor  $E$  is completely determined by the data  $E(\text{super-pt}) = \bar{E}(\text{pt})$  and  $D$ .

*Example 10.4.* If  $M$  is a Riemannian spin manifold, then we get  $E \in 1|1\text{-EFT}$  by setting  $E(\text{pt})$  to the smooth spinors on  $M$  and using the Dirac operator  $\not{D}_M$  for  $D$ . The reduced field theory  $\bar{E}$  has the same vector space, but one considers the operator  $\not{D}_M^2$  for the operator  $A$ .

It is important to remark that in our discussion in the previous two paragraphs we have only been discussing the data which determines the EFT. There are theorems which we have not discussed which connect this data with the definition.

Now, an  $E \in 1|1\text{-EFT}^{-n}$  determines

- (1) a  $\mathbb{Z}/2\mathbb{Z}$ -graded right  $C_n$ -module  $E(\text{pt})$ . (Here  $C_n$  denotes the Clifford algebra of  $\mathbb{R}^n$ .)
- (2) an odd Clifford linear operator  $D: E(\text{pt}) \rightarrow E(\text{pt})$  with certain properties...

and conversely  $E$  is determined by this data. Our goal for the rest of this lecture is to make progress towards showing that if  $M$  is a closed spin manifold of dimension  $n$ , then the Clifford linear Dirac operator on  $M$  determines a 1|1-EFT of degree  $-n$ . We will call this EFT the one dimensional non-linear  $\sigma$ -model of  $M$  and write  $\sigma_1(M)$ .

**Definition 10.5.** A *spin structure* on a Riemannian manifold  $M$  is a double covering

$$\begin{array}{ccc} \text{Spin}(M) & \longrightarrow & \text{SO}(M) \\ & \searrow & \downarrow \\ & & M \end{array}$$

where  $\text{SO}(M)$  is the oriented orthonormal frame bundle of  $M$ .

Automatically then, if  $\dim M = n$ , then  $\text{Spin}(M) \rightarrow M$  is a principal  $\text{Spin}(n)$ -bundle.

**Definition 10.6.** Let  $(V, \langle \cdot, \cdot \rangle)$  be a real inner product space and denote by  $\mathcal{T}(V)$  the tensor algebra over  $V$ . The *Clifford algebra* of  $V$  is defined as the quotient

$$\text{Cl}(V) := \mathcal{T}(V) / (v \otimes v + |v|^2 \cdot 1 : v \in V).$$

Note that  $\mathcal{T}(V)$  is a  $\mathbb{Z}$ -graded algebra and therefore also a  $\mathbb{Z}/2\mathbb{Z}$ -graded algebra as well. The ideal of relations in the Clifford algebra is not homogeneous, so the Clifford algebra of  $V$  is not  $\mathbb{Z}$ -graded, however it is  $\mathbb{Z}/2\mathbb{Z}$ -graded. Furthermore, there is an important consequence of the relations concerning products of differing elements of  $V$ . By the relation

$$\begin{aligned} (v + w) \cdot (v + w) &= -\|v + w\|^2 \cdot 1 \\ v \cdot v + w \cdot w + v \cdot w + w \cdot v &= -(|v|^2 + |w|^2 + 2\langle v, w \rangle) \end{aligned}$$

and thus  $v \cdot w + w \cdot v = -2\langle v, w \rangle \cdot 1$ . As a corollary, we see that perpendicular vectors in  $V$  anti-commute as elements of the Clifford algebra.

## 11. THE 1|1-CASE.

Last time we discussed how topology and physics fit together in our discussion of Euclidean field theories of dimension 2|1. One of the most encouraging rigorous results toward completing that diagram is the following.

**Theorem 11.1.** *The partition function of a 2|1-EFT of degree  $n$  is a weakly holomorphic integral modular form.*

Let us remark that we would like to have a stronger version of this diagram, a connective version of Euclidean field theories which can be related to  $\text{tmf}$  and thus to honest integral modular forms  $\text{mf}$ .

Here is an analogous diagram in dimension 1|1 in which all arrows are rigorously defined.

$$\begin{array}{ccc}
 & \text{Riemannian Spin Manifolds} & \\
 \swarrow & & \searrow \\
 1|1\text{-EFT}^{-n}[\text{pt}] & \xleftrightarrow{\text{Iso}} & \text{KO}^{-*} \\
 \searrow & & \swarrow \\
 & \mathbb{Z}[\frac{\omega}{2}, (\frac{\omega}{2})^{-1}] &
 \end{array}$$

$\xrightarrow{Z}$  (from  $1|1\text{-EFT}^{-n}[\text{pt}]$  to  $\mathbb{Z}[\frac{\omega}{2}, (\frac{\omega}{2})^{-1}]$ )  
 $\xrightarrow{\Phi \simeq \mathbb{Q}}$  (from  $\text{KO}^{-*}$  to  $\mathbb{Z}[\frac{\omega}{2}, (\frac{\omega}{2})^{-1}]$ )

As a graded ring  $\text{KO}^{-*}$  is isomorphic to  $\mathbb{Z}[\eta, \omega, \mu, \mu^{-1}]/(2\eta, \eta^3, \eta\omega, \omega^2 - 4\mu)$  where the generators  $\eta$ ,  $\omega$ , and  $\mu$  are in degrees  $-1$ ,  $-4$ , and  $-8$ , respectively. Given a Riemannian spin manifold  $M$ , we can construct the Atiyah invariant  $\alpha(M) \in \text{KO}^{-*}$ . The rational isomorphism  $\Phi$  determined by  $\omega \mapsto \frac{\omega}{2}$  (interpreted as a formal generator) sends  $\alpha(M)$  to  $\hat{A}(M)(\frac{\omega}{2})^{\dim M/4}$  where we interpret the exponent as zero when  $\dim M$  is not divisible by four. On the other hand we can construct a 1|1-EFT of degree equal to  $\dim M$ , the quantization of a super particle moving in  $M$ , which we call the one dimensional non-linear  $\sigma$ -model of  $M$ ,  $\sigma_1(M)$ . The partition function depends only on the concordance class of this theory and yields the  $\hat{A}$ -genus of  $M$ . There is an isomorphism relating  $1|1\text{-EFT}^{-*}[\text{pt}]$  and  $\text{KO}^{-*}$  making the diagram commute.

Recall that 1|1-EFT of degree  $-n$  is determined by the pair  $(V, D)$  where  $V$  is a  $\mathbb{Z}/2\mathbb{Z}$ -graded topological vector space and a right  $C_n$ -module ( $C_n$  denotes the Clifford algebra of  $\mathbb{R}^n$ ) and  $D$  is an odd linear operator such that  $e^{-tD^2}$  is trace class for each  $t > 0$ . The  $\sigma$ -model  $\sigma_1(M)$  comes from  $(V, D)$  where  $V$  is the space of Clifford linear spinors on  $M$  and  $D$  is the Clifford linear Dirac operator on  $M$ .

Let's recall the construction of the group  $\text{Spin}(n)$ . Let  $\text{Pin}(n)$  denote the subgroup of the units in  $C_n$  generated by the unit vectors in  $\mathbb{R}^n$ . Given a generator  $v$ , the assignment of  $v$  to the reflection in  $\mathbb{R}^n$  through the hyperplane normal to  $v$  determines a homomorphism  $\text{Pin}(n) \rightarrow \text{O}(n)$  which is a  $2 : 1$  cover. The intersection  $\text{Pin}(n) \cap C_n^{\text{even}}$  is the group  $\text{Spin}(n)$  and the previous map restricts to a double covering of  $\text{SO}(n)$ .

Suppose  $M$  is a Riemannian spin manifold of dimension  $n$ . Let  $\Delta$  be a  $\mathbb{Z}/2\mathbb{Z}$ -graded representation of  $\text{Spin}(n)$ . The choice of this representation gives rise to a spinor bundle  $S = \text{Spin}(M) \times_{\text{Spin}(n)} \Delta \rightarrow M$ . Of course  $S$  decomposes as  $S^+ \oplus S^-$  into even and odd parts where  $S^\pm = \text{Spin}(M) \times_{\text{Spin}(n)} \Delta^\pm$ . Note that the factors  $\Delta^\pm$  are representations of  $\text{Spin}(n)$ , but not of  $\text{Pin}(n)$  since the latter group has odd elements.

The Levi-Cevita connection in  $TM$  induces a connection in the principal  $\text{SO}(n)$ -bundle  $\text{SO}(M)$  which lifts to a connection in  $\text{Spin}(M)$ . This, in turn, induces a connection in the associated bundle  $S$  and a covariant derivative  $\nabla: C^\infty(S) \rightarrow C^\infty(T^*M \otimes S)$ . The metric gives an isomorphism  $T^*M \rightarrow TM$  and allows us to define a fiberwise action of the Clifford algebra generated by  $T_m^*M$  on  $S_m$ . We denote this Clifford multiplication bundle map by  $c: T^*M \otimes S \rightarrow S$ . The Dirac operator acting in  $S$  is defined by the composition of these two maps.

$$\mathcal{D}_M: C^\infty(S) \xrightarrow{\nabla} C^\infty(T^*M \otimes S) \xrightarrow{c} C^\infty(S)$$

The Clifford linear Dirac operator is that obtained by choosing the representation  $\Delta$  of  $\text{Spin}(n)$  to be the Clifford algebra  $C_n$  itself. The corresponding spinor bundle  $S = \text{Spin}(M) \times_{\text{Spin}(n)} C_n$  then has the additional structure of a right  $C_n$  action on its fibers. As a result,  $C^\infty(S)$  is a  $\mathbb{Z}/2\mathbb{Z}$ -graded topological vector space over  $\mathbb{R}$  (Fréchet topology) and a right  $C_n$ -module. (Note that usual spinor representation taken has roughly dimension  $2^{n/2}$ , whereas this representation has dimension  $2^n$  and so is much larger.) The upshot is that the corresponding Dirac operator  $\mathcal{D}_M: C^\infty(S) \rightarrow C^\infty(S)$  for this spinor bundle  $S$  is right  $C_n$ -linear. In particular, the eigenspaces of  $\mathcal{D}_M$  are finite dimensional modules over  $C_n$ .

Let  $S$  denote the Clifford linear spinor bundle of  $M$  and write  $S_\Delta$  for the bundle of spinors that depends on the choice of representation  $\Delta$ . Note that no information is lost by considering the Clifford linear Dirac operator, since we can always recover  $S_\Delta$  from  $S$  by tensoring with  $\Delta$  over  $C_n$  on the right.

$$(\text{Spin}(M) \times_{\text{Spin}(n)} C_n) \otimes_{C_n} \Delta = \text{Spin}(M) \times_{\text{Spin}(n)} \Delta$$

Via this process the Clifford linear Dirac operator is converted to the corresponding Dirac operator by  $\mathcal{D}_M \mapsto \mathcal{D}_M \otimes 1 = D_M$ .

To finish today, let us just record the Clifford algebras up to isomorphism for the first few  $n$ . By  $\mathbb{R}$ ,  $\mathbb{C}$ , and  $\mathbb{H}$ , we mean the real numbers, complex numbers, and Hamiltonian quaternions, respectively. If  $R$  is a ring (algebra) then we denote by  $R(n)$  the ring (algebra) of  $n \times n$  matrices with entries in  $R$ .

$n$	0	1	2	3	4	5	6	7	8	9
$C_n$	$\mathbb{R}$	$\mathbb{C}$	$\mathbb{H}$	$\mathbb{H} \oplus \mathbb{H}$	$\mathbb{H}(2)$	$\mathbb{C}(4)$	$\mathbb{R}(8)$	$\mathbb{R}(8) \oplus \mathbb{R}(8)$	$\mathbb{R}(16)$	$\mathbb{C}(16)$

Given an orthonormal basis  $e_1, \dots, e_n$  for  $\mathbb{R}^n$  the set  $\{e_{i_1} \dots e_{i_k} \mid i_1 < \dots < i_k\}$  forms a basis of  $C_n$  over  $\mathbb{R}$ , so  $\dim_{\mathbb{R}} C_n = 2^n$ . These algebras exhibit a type of 8-fold periodicity, namely  $C_{n+8} \simeq C_n(16)$  for each  $n$ , and this is linked to the 8-fold periodicity in KO-theory.

## 12. THE 1|1-NONLINEAR SIGMA MODEL AND KO

Let  $M$  be a Riemannian spin manifold of dimension  $n$ . Our goal today is to describe the one dimensional supersymmetric non-linear  $\sigma$ -model of  $M$ ,  $\sigma_1(M)$ , in terms of the data which determines it as a 1|1-EFT of degree  $-n$  and show how it is related to  $\text{KO}^{-n}$ .

The functor  $\sigma_1(M)$  is determined by the pair  $(V, D)$  where  $V$  is the space of Clifford linear spinors on  $M$  and  $D$  is the  $C_n$ -linear Dirac operator on  $M$ . Let  $S$  denote the  $C_n$ -linear spinor bundle over  $M$ .

Let's discuss these data for the case where  $M$  is a circle of length  $\ell$ . Since  $\text{SO}(1)$  is the trivial group the bundle  $\text{SO}(M) \rightarrow M$  is the trivial covering of  $S^1$  by itself. The spin group is  $\text{Spin}(1) = \{\pm 1\}$  and there are two possible spin structures, one is the trivial covering of  $S^1$  by itself and the other is the Möbius covering. We call the former the *periodic spin structure* and the latter the *anti-periodic spin structure*. The Clifford algebra  $C_1$  is  $\mathbb{C}$  as an algebra over  $\mathbb{R}$ , so the Clifford linear spinor bundle is  $S = \text{Spin}(M) \times_{\pm 1} \mathbb{C}$ . As a bundle over  $\mathbb{C}$ , this is a trivial bundle in both cases, but as a direct sum of  $\mathbb{R}$  sub-bundles it is trivial in the periodic case but

non-trivial in the anti-periodic case. We have the following identifications.

$$C^\infty(S) = \begin{cases} \{\text{smooth } f: \mathbb{R} \rightarrow \mathbb{C}: f(t + \ell) = f(t)\} & \text{periodic case} \\ \{\text{smooth } f: \mathbb{R} \rightarrow \mathbb{C}: f(t + \ell) = -f(t)\} & \text{anti-periodic case} \end{cases}$$

For the Dirac operator, we need to compute the covariant derivative. The Levi-Cevita connection on  $M$  is identified with the ordinary derivative with respect to the coordinate  $t$ . The induced covariant derivative in  $S$  is also simply differentiation with respect to  $t$  since the structure group of  $S$  in this case is discrete. In our identifications,  $t$  is the arc-length coordinate on  $M$ , so  $dt$  is a unit vector in the cotangent space at each point. Under Clifford multiplication, this is equivalent to multiplication by  $i$  in  $\mathbb{C}$ , so  $Df = i \frac{df}{dt}$ .

The eigenspinors on  $M$  are of the form

$$e^{2\pi i k t / \ell} \text{ for } k \in \begin{cases} \mathbb{Z} & \text{periodic case} \\ \mathbb{Z} + \frac{1}{2} & \text{anti-periodic case} \end{cases}$$

with corresponding eigenvalue  $2\pi k / \ell$ . So we see that the spectrum is discrete and symmetric about zero in  $\mathbb{R}$ . Furthermore,  $\ker D = \mathbb{C}$  in the periodic case and  $\ker D = \{0\}$  in the anti-periodic case.

Recall that  $\text{KO}^0(X)$  denotes the Grothendieck group of isomorphism classes of real vector bundles over  $X$ , technically a set of isomorphism classes of pairs  $(E, F)$  where  $E$  and  $F$  are vector bundles over  $X$ , modulo an equivalence relation. Similarly,  $\text{KO}_c^0(X)$  denotes the real  $K$ -theory with compact support and is a Grothendieck group formed from a set of triples  $(E, F, \alpha)$  where  $E$  and  $F$  are as before, but  $\alpha: E \rightarrow F$  is vector bundle map with compact support.<sup>8</sup> This turns out to be equivalent to  $\text{KO}^0(X_+)$ .

Recall that  $C_n$  denotes the Clifford algebra of  $\mathbb{R}^n$ . Let  $\mathcal{M}(C_n)$  denote the Grothendieck group of isomorphism classes of  $\mathbb{Z}/2\mathbb{Z}$ -graded  $C_n$ -modules. Via the inclusion  $\iota: C_n \rightarrow C_{n+1}$  there is an induced map  $\iota^*: \mathcal{M}(C_{n+1}) \rightarrow \mathcal{M}(C_n)$ . The following theorem is a beautiful result and the paper [ABS] is a classic work in the subject of  $K$ -theory.

**Theorem 12.1** (Atiyah-Bott-Shapiro).  $\mathcal{M}(C_n) / \iota^* \mathcal{M}(C_{n+1}) \simeq \text{KO}^{-n}$

Recall that  $\text{KO}^{-n} \simeq \widetilde{\text{KO}}(S^n) = \text{KO}_c^0(\mathbb{R}^n)$  via the suspension isomorphism. Atiyah, Bott, and Shapiro defined a map  $\mathcal{M}(C_n) \rightarrow \text{KO}_c^0(\mathbb{R}^n)$  by sending a  $C_n$ -module  $\Delta$  to the triple  $(\mathbb{R}^n \times \Delta^{\text{even}}, \mathbb{R}^n \times \Delta^{\text{odd}}, \alpha: \mathbb{R}^n \times \Delta^{\text{ev}} \rightarrow \mathbb{R}^n \times \Delta^{\text{odd}})$ , where the first two factors are the trivial bundles over  $\mathbb{R}^n$  and the bundle map  $\alpha$  is defined by  $(v, \lambda) \mapsto (v, v \cdot \lambda)$  using Clifford multiplication. Note that  $v \cdot v \cdot \lambda = \|v\|^2 \lambda$ , so  $\alpha$  fails to be an isomorphism only at  $v = 0 \in \mathbb{R}^n$ . This map is a homomorphism of abelian groups.

It is a fact, which we will state without proof, that the ABS map is compatible with multiplication given by tensor products in  $\text{KO}$ -theory. The *graded* tensor product  $C_n \otimes C_m$  is isomorphic to  $C_{m+n}$ . In fact, all finite dimensional Clifford algebras are isomorphic to *graded* tensor powers of  $C_1$ . Given  $M \in \mathcal{M}(C_m)$  and  $N \in \mathcal{M}(C_n)$  one can form  $N \otimes_{\mathbb{R}} M$  and obtain a  $C_{m+n}$ -module.<sup>9</sup>

<sup>8</sup>The support of a vector bundle map  $\alpha: E \rightarrow F$  is the closure of the set of all  $x \in X$  where  $\alpha$  fails to be an isomorphism on the fiber.

<sup>9</sup>N.B. The action of  $C_n \otimes C_m$  on  $N \otimes M$  is described by the map  $(C_n \otimes C_m) \otimes (N \otimes M) \rightarrow (N \otimes M)$ ,  $(c \otimes d) \otimes (n \otimes m) \mapsto (-1)^{|d||n|} cn \otimes dm$ .

Recall that as a ring

$$\mathrm{KO}^{-*} \simeq \mathbb{Z}[\eta, \omega, \mu, \mu^{-1}] / (2\eta, \eta^3, \eta\omega, \omega^2 - 4\mu)$$

where the generators  $\eta$ ,  $\omega$ , and  $\mu$  have degrees  $-1$ ,  $-4$ , and  $-8$  respectively. Recall that  $C_1 = \mathbb{C}$ ,  $C_4 = \mathbb{H}(2)$ , and  $C_8 = \mathbb{R}(16)$ . Let us note that the  $\mathbb{Z}/2\mathbb{Z}$ -decomposition of both  $C_4 = \mathbb{H}(2)$  and  $C_8 = \mathbb{R}(16)$  into even and odd parts is the decomposition into two by two block-diagonal and block-off-diagonal matrices. Corresponding to each of the generators of  $\mathrm{KO}^{-*}$  is then an equivalence class of modules over  $C_n$ . The table below gives representatives for these classes associated to the generators via the ABS map.

$\mathrm{KO}^{-n}$ generator	$\mathcal{M}(C_n)/\iota^*\mathcal{M}(C_{n+1})$
$\eta$	$\mathbb{C} = \mathbb{R} \oplus i\mathbb{R}$
$\omega$	$\mathbb{H}^2 = \mathbb{H} \oplus \mathbb{H}$
$\mu$	$\mathbb{R}^{16} = \mathbb{R}^8 \oplus \mathbb{R}^8$

The relations in  $\mathrm{KO}^{-*}$  can be seen algebraically. For example,  $2\eta$  corresponds to  $\mathbb{C} \oplus \mathbb{C}$  which can be identified as a  $\mathbb{Z}/2\mathbb{Z}$ -graded algebra with  $\mathbb{H}$ . So it certainly extends over  $C_2 = \mathbb{H}$ . Thus  $2\eta$  corresponds to 0.

Now, let us define a map  $\psi: 1|1\text{-EFT}^{-n}[\mathrm{pt}] \rightarrow \mathcal{M}(C_n)/\iota^*\mathcal{M}(C_{n+1})$ . Recall the assertion that a  $1|1\text{-EFT}$  of degree  $-n$  is determined the data of a right  $C_n$ -module  $V$  together with a  $C_n$ -linear odd operator  $D$ . To this pair we will associate the  $C_n$ -module  $\ker(D)$ . Of course, we now need to check that this assignment descends to concordance classes in the domain and to equivalence classes of modules in the range.

**Proposition 12.2.**  *$\psi$  is well-defined.*

*Proof.* Let  $\mathrm{spec}(D)$  denote the spectrum of  $D$ . Recall that this is assumed to be discrete in  $\mathbb{C}$ . Given an eigenvalue  $\lambda \in \mathrm{spec}(D)$ , let  $E_\lambda$  denote the eigenspace in  $V$  associated to  $\lambda$ . To prove the proposition, we will first establish the following claims.

- i)  $E_\lambda$  is a  $C_n$ -module (but not a graded  $C_n$ -module unless  $\lambda = 0$ ).
- ii)  $E_\lambda \oplus E_{-\lambda}$  is a  $\mathbb{Z}/2\mathbb{Z}$ -graded  $C_n$ -module.
- iii) For  $\lambda \neq 0$ , the  $C_n$ -module structure on  $E_\lambda \oplus E_{-\lambda}$  extends to a  $C_{n+1}$ -module structure.

Claim i) is clear. To establish ii), we need to show that  $E_\lambda \oplus E_{-\lambda}$  is invariant under the grading involution  $\epsilon$ . Let  $v \in E_\lambda$ , then  $D\epsilon v = -\epsilon Dv = -\lambda\epsilon v$  since  $D$  is an odd operator. Thus  $\epsilon v \in E_{-\lambda}$ .

Claim iii) is a bit more subtle. To show that the  $C_n$ -module structure extends, it suffices to show how to define the Clifford action of the basis element  $e_{n+1}$  of  $\mathbb{R}^{n+1}$ . Set

$$e_{n+1}.v = \frac{\epsilon D}{|\lambda|}v.$$

Then

$$e_{n+1}^2 = \frac{\epsilon D \epsilon D}{|\lambda|^2} = \frac{-\epsilon^2 D^2}{|\lambda|^2} = -\frac{|\lambda|^2}{|\lambda|^2} = -1$$

on  $E_\lambda$  and

$$e_{n+1}\epsilon = \frac{\epsilon D}{|\lambda|^2}\epsilon = \frac{-\epsilon^2 D}{|\lambda|} = -\epsilon e_{n+1}.$$

Finally, since  $D$  is right Clifford linear, we have

$$e_{n+1}e_i = \frac{\epsilon D \cdot e_i}{|\lambda|} = \frac{\epsilon e_i D}{|\lambda|} = -e_i e_{n+1}.$$

So we have extracted an element of  $\mathcal{M}(C_n)/\iota^*\mathcal{M}(C_{n+1})$  from our 1|1-EFT of degree  $-n$ . Note that it was essential that  $D$  was an odd operator.

Next we ask the question: what happens when we deform the operator  $D$ ? Recall that one can think of concordant 1|1-EFT's as being connected by a one parameter family of 1|1-EFT's and each element of the family is determined by a pair  $(V, D)$  where  $D$  is an odd operator. Tracking the movement of the eigenvalues of  $D$  as we move through the family, we see that  $\ker D$  is not invariant under deformation, since some eigenvalues may go to zero. But, the spectrum of  $D$  is symmetric about the origin so  $E_0$  can only be replaced by  $E_0 \oplus E_\lambda \oplus E_{-\lambda}$  where  $\lambda \rightarrow 0$ . But by claim iii) above,  $E_\lambda \oplus E_{-\lambda}$  is a module over  $C_{n+1}$ , so this change is accounted for by  $\iota^*\mathcal{M}(C_{n+1})$ . Hence deformation does not change  $[\ker D]$ .  $\square$

### 13. THE $\hat{A}$ -GENUS AS A PARTITION FUNCTION

$$\begin{array}{ccc}
 & \text{Riemannian Spin Manifolds} & \\
 \swarrow \sigma_1 & & \searrow \alpha \\
 1|1\text{-EFT}^{-n}[\text{pt}] & \xrightarrow{\psi} \mathcal{M}(C_n)/\iota^*\mathcal{M}(C_{n+1}) & \xleftarrow{\text{ABS}} \text{KO}^{-n}
 \end{array}$$

Last time we constructed a map  $\psi$  from concordance classes of 1|1-EFT's of degree  $-n$  to  $\text{KO}^{-n}$  using the Atiyah-Bott-Shapiro description of  $\text{KO}^{-*}$ . This map is, in fact, an isomorphism but since we have not yet properly defined a 1|1-EFT of degree  $-n$ , we cannot yet discuss the proof.

Given a Riemannian spin manifold of dimension  $n$ , we can construct the 1|1-dimensional non-linear sigma model of  $M$ , the quantum mechanics of a super particle moving in  $M$ , and obtain a 1|1-EFT of degree  $-n$ . On the other hand, we can compute the Atiyah invariant  $\alpha(M)$  and obtain an element of  $\text{KO}^{-n}$ . The above diagram commutes by the Clifford linear version of the Atiyah-Singer-Index theorem. Let us remark that the middle line of the diagram can be interpreted for all  $n \in \mathbb{Z}$ , not just for  $n \geq 0$ . The Atiyah invariant is surjective for  $n \geq 0$ .

As an example, let's consider again the circle  $M = S^1$  with length  $\ell$ . Let  $V$  denote the Clifford linear spinors on  $M$  and let  $D$  be the Clifford linear Dirac operator. Recall that there are two possible spin structures, the periodic case and the anti-periodic case, and  $\ker D$  is trivial in the anti-periodic case and equal to  $\mathbb{C} = C_1$  in the periodic case. The map  $\psi$  associates to the pair  $(V, D)$  the class  $[\ker D] \in \text{KO}^{-1} = \mathbb{Z}/2\mathbb{Z}$ . This class is trivial in the anti-periodic case and hits the generator  $\eta$  in the periodic case.

Note that in this example everything is multiplicative. If  $M = S^1 \times S^1$ , with the period spin structure on each factor, then  $\psi(\sigma_1(M))$  goes to  $\eta^2$  as does the Atiyah invariant. The generator  $\omega$  is hit by the K3 surface since its  $\hat{A}$ -genus is 2. Dominic Joyce constructed an example of a Spin(7)-manifold with  $\hat{A}(M) = 1$  and its Atiyah invariant is the generator  $\mu$ .

Now we would like to consider the information retained by the partition function. We will define the partition function of a 1|1-EFT of degree  $n$  by first showing how to reduce to a 1|1-EFT of degree 0 and then evaluating this reduction on circles.

To reduce to a degree 0 EFT, we make a choice of a graded  $C_n$  module  $\Delta$  and then tensor over  $C_n$ .

$$\begin{array}{ccc} [V, D] & \xrightarrow{\psi} & [\ker D] \in \mathrm{KO}^{-n} \\ \otimes_{C_n} \downarrow & & \downarrow \otimes_{C_n} \\ [V \otimes_{C_n} \Delta, D \otimes \mathrm{id}] & \longrightarrow & \mathcal{M}(C_0)/\iota^* \mathcal{M}(C_1) = \mathrm{KO}^0 = \mathbb{Z} \end{array}$$

Recall also that given  $E \in 1|1\text{-EFT}$ , we can obtain  $\overline{E} \in 1\text{-EFT}$ .

**Definition 13.1.** The partition function of  $E \in 1|1\text{-EFT}$  is the function  $Z_E: \mathbb{R}_{>0} \rightarrow \mathbb{C}$  obtained by evaluating  $\overline{E}$  on the circle of length  $\ell \in \mathbb{R}_{>0}$ , viewed as a morphism from the empty set to itself in the Euclidean bordism category.

If  $E$  is determined by the pair  $(V, D)$ , the  $\overline{E}(S_\ell^1)$  is multiplication on  $\mathbb{C}$  by the number  $\mathrm{str}(e^{-\ell D^2}) = \overline{E}(S_\ell^1) =: Z_E(\ell)$ .

**Proposition 13.2.** For a given  $E \in 1|1\text{-EFT}$ , the partition function  $Z_E$  is a constant integer valued function on  $\mathbb{R}_{>0}$ .

*Proof.* Let  $\mathrm{spec}(D^2)$  denote the set of eigenvalues  $\lambda$  of  $D^2$  and for each eigenvalue  $\lambda$ , let  $E_\lambda$  denote the corresponding eigenspace. Then

$$\mathrm{str}(e^{-\ell D^2}) = \sum_{\lambda \in \mathrm{spec}(D^2)} e^{-\ell \lambda} \mathrm{sdim}(E_\lambda)$$

where  $\mathrm{sdim}(E_\lambda) = \dim(E_\lambda^{\mathrm{ev}}) - \dim(E_\lambda^{\mathrm{odd}})$  is the super dimension of the  $\mathbb{Z}/2\mathbb{Z}$ -graded vector space  $E_\lambda$ . The operator  $D$  interchanges  $E_\lambda^{\mathrm{ev}}$  and  $E_\lambda^{\mathrm{odd}}$  because it is an odd operator and furthermore, it is an isomorphism if  $\lambda \neq 0$ . This implies that  $\mathrm{sdim}(E_\lambda) = 0$  unless  $\lambda = 0$ . Hence  $\mathrm{str}(e^{-\ell D^2}) = \mathrm{sdim}(\ker(D^2)) = \mathrm{sdim}(\ker D) \in \mathbb{Z}$  independent of  $\ell$ .  $\square$

The point is that the partition function  $Z_E$  forgets the torsion information in the concordance classes of  $1|1\text{-EFT}$ 's and produces an integer, much the same way that the  $\hat{A}$ -genus forgets the torsion information in the Atiyah invariant.

Now we would like to switch gears a little bit and head back in the direction of topological modular forms. First we will discuss modular forms and partition functions of field theories.

Let  $E$  be a 2-CFT (recall that when we do not specify the degree, we mean degree zero). Then  $E$  is a functor  $E: 2\text{-CB} \rightarrow \mathrm{TV}$ . Viewing a closed 2 surface  $\Sigma$  with a conformal structure as a conformal bordism from the empty set to itself,  $E(\Sigma) \in \mathrm{Hom}(E(\emptyset), E(\emptyset)) = \mathrm{Hom}(\mathbb{C}, \mathbb{C}) = \mathbb{C}$  is multiplication by a complex number.

Recall that we defined the partition function  $Z_E: \mathfrak{h} \rightarrow \mathbb{C}$  by assigning to  $\tau \in \mathfrak{h}$  the complex number  $E(\mathbb{C}/\Lambda_\tau)$  where  $\Lambda_\tau$  is the lattice  $\mathbb{Z} + \tau\mathbb{Z}$  in  $\mathbb{C}$ . Two such tori  $\mathbb{C}/\Lambda_\tau$  and  $\mathbb{C}/\Lambda_{\tau'}$  are conformally equivalent if  $\tau$  and  $\tau'$  belong to the same orbit under the action of  $\mathrm{SL}(2, \mathbb{Z})$  on  $\mathfrak{h}$  by linear fractional transformations. This implies that  $Z_E$  for  $E \in 2\text{-CFT}$  is a modular function, i.e., it is a function on  $\mathfrak{h}$  which transforms under the action of  $\mathrm{SL}(2, \mathbb{Z})$  as a modular form of weight zero.

It is important to note that we considered only genus 1 bordisms from the empty set to itself when considering the partition function. More generally, one could produce a function on Teichmüller space which is invariant under the action of the mapping class group. We restrict our attention to genus one surfaces because we are interested in topological modular forms which have to do with elliptic curves.

## 14. FUNCTIONS TRANSFORMING AS MODULAR FORMS

Recall that  $E \in 2\text{-CFT}$  is a functor  $E: 2\text{-CB} \rightarrow \text{TV}$  from the conformal bordism category to  $\text{TV}$ . If  $\Sigma$  is a closed 2-manifold with orientation and conformal structure (equivalently,  $\Sigma$  is a Riemann surface) then  $\Sigma$  can be viewed as a conformal bordism from the empty set to itself and thus  $E(\Sigma)$  is a complex number. The partition function  $Z_E: \mathfrak{h} \rightarrow \mathbb{C}$  is defined by the values of  $E$  on  $\Sigma = \mathbb{C}/\Lambda_\tau$  where  $\Lambda_\tau = \mathbb{Z} + \tau\mathbb{Z}$  for  $\tau \in \mathfrak{h}$  and is a modular invariant function.

We have not yet defined field theories of non-zero degree, but for  $E \in 2\text{-CFT}^{2k}$ ,  $E(\Sigma) \in \text{Det}_\Sigma^{\otimes k}$  for each  $k \in \mathbb{Z}$ , where  $\text{Det}_\Sigma$  is a certain complex line depending on  $\Sigma$  which we will now define. Let  $\Sigma$  be a complex curve. The complex structure on  $\Sigma$  induces an almost complex structure in  $T^*\Sigma$ , i.e., a bundle endomorphism which squares to minus  $-1$ . The complexified bundle  $T^*\Sigma \otimes_{\mathbb{R}} \mathbb{C}$  splits as a direct sum of holomorphic line bundles  $T^{*1,0}\Sigma$  and  $T^{*0,1}\Sigma$ , the eigenbundles of the almost complex structure corresponding to  $i$  and  $-i$  respectively. We denote by  $\Omega_{\text{hol}}^1$  the holomorphic sections of  $T^{*1,0}\Sigma$ , and refer to the elements as holomorphic 1-forms on  $\Sigma$ .

For  $\Sigma = \mathbb{C}/\Lambda_\tau$ , we can identify the elements of  $\Omega_{\text{hol}}^1(\Sigma)$  with holomorphic 1-forms on  $\mathbb{C}$  of the form  $f(z)dz$  where  $f$  is holomorphic on  $\mathbb{C}$  and periodic with respect to the lattice  $\Lambda_\tau$ . Since any such function is bounded, we obtain by Liouville's theorem that  $f$  is necessarily constant and hence  $\Omega_{\text{hol}}^1(\mathbb{C}/\Lambda_\tau) = \mathbb{C}$ . In general  $\Omega_{\text{hol}}^1(\Sigma)$  is a finite dimensional vector space over  $\mathbb{C}$ .

**Definition 14.1.** Let  $\Sigma$  be a closed Riemann surface. The complex line

$$\text{Det}_\Sigma := \bigwedge^{\text{top}} (\Omega_{\text{hol}}^1(\Sigma)^\vee)$$

is called the *determinant line* of  $\Sigma$ .

If  $k = -n$  is a negative integer, then we define  $\text{Det}_\Sigma^{\otimes k} := (\text{Det}_\Sigma^\vee)^{\otimes n}$ .

**Proposition 14.2.** *If  $F: \Sigma \rightarrow \Sigma'$  is a conformal equivalence, then we obtain induced isomorphisms*

$$\Omega_{\text{hol}}^1(\Sigma) \xleftarrow{F^*} \Omega_{\text{hol}}^1(\Sigma') \quad \text{and} \quad \text{Det}_\Sigma^{\otimes k} \xrightarrow{F_*} \text{Det}_{\Sigma'}^{\otimes k}.$$

We will require the following property of our functors  $E$ :

(14.1)

$\Sigma \rightarrow \Sigma'$  a conformal equivalence  $\Rightarrow E(\Sigma) \mapsto E(\Sigma')$  under this isomorphism.

*Remark 14.3.*

- i) The determinant lines  $\text{Det}_\Sigma$  for  $\Sigma = \mathbb{C}/\Lambda_\tau$  stitch together to form a holomorphic line bundle  $\text{Det}$  over  $\mathfrak{h}$  with  $\text{Det}_\tau = \text{Det}_{\mathbb{C}/\Lambda_\tau}$ . It is equivariant with respect to the action of  $\text{SL}(2, \mathbb{Z})$ . Unfortunately the moduli space  $\mathfrak{h}/\text{SL}(2, \mathbb{Z})$  is not a manifold since there are two values of  $\tau$  with non-trivial finite stabilizers, so there is no vector bundle over the moduli space. Instead we work equivariantly.
- ii) There is a generalization of the determinant line to the Teichmüller space of genus  $g$  curves. The mapping class group  $\pi_0(\text{Diff}(\Sigma_g))$  acts on Teichmüller space and the quotient is the moduli space of genus  $g$  curves.
- iii) If  $E$  is an assignment from genus one curves  $\Sigma$  to  $E(\Sigma) \in \text{Det}^{\otimes k}$  such that property (14.1) holds, then we get a section  $\text{Det}^{\otimes k} \rightarrow \mathfrak{h}$  by setting

$s(\tau) = E(\mathbb{C}/\Lambda_\tau)$ . To get a *smooth* or *holomorphic* section we will need further assumptions on  $E$ . We would like to classify all such assignments.

**Proposition 14.4.** *The assignments  $\Sigma \rightarrow E(\Sigma) \in \text{Det}^{\otimes k}$  such that (14.1) holds are in bijection with the set of functions  $f: \mathfrak{h} \rightarrow \mathbb{C}$  which transform as a modular form of weight  $-k$ .*

*Idea of proof.* Let's trivialize  $\text{Det}$  over  $\mathfrak{h}$  to read a section as a function of  $\tau$ . We define a map  $H_1(\mathbb{C}/\Lambda_\tau, \mathbb{Z}) \rightarrow \text{Det}|_{\mathbb{C}/\Lambda_\tau} = \Omega_{\text{hol}}^1(\mathbb{C}/\Lambda_\tau)^\vee$  as follows. Note first that  $H_1(\mathbb{C}/\Lambda_\tau, \mathbb{Z}) = \pi_1(\mathbb{C}/\Lambda_\tau) = \Lambda_\tau$ . Given a loop  $\gamma \in \pi_1(\mathbb{C}/\Lambda_\tau)$  we define a linear functional on holomorphic 1-forms  $\omega$  by  $\omega \mapsto \int_{S^1} \gamma^* \omega$ . Under this map,  $1 \in \Lambda_\tau = \pi_1(\mathbb{C}/\Lambda_\tau)$  maps to  $\xi_\tau$  which is the functional sending  $dz \rightarrow \int_{S^1} \gamma^* dz = 1$ .

Let  $\tau \in \mathfrak{h}$  and

$$A = \begin{pmatrix} a & b \\ c & d \end{pmatrix} \in \text{SL}(2, \mathbb{Z})$$

and set  $\tau' = \frac{a\tau+b}{c\tau+d}$ . Define a diffeomorphism  $F_A: \mathbb{C}/\Lambda_{\tau'} \rightarrow \mathbb{C}/\Lambda_\tau$  by the assignment  $[z] \mapsto [(c\tau+d)z]$ . Then  $(F_A)_*: \text{Det}_{\mathbb{C}/\Lambda_{\tau'}} \rightarrow \text{Det}_{\mathbb{C}/\Lambda_\tau}$  sends  $\xi_{\tau'} \rightarrow (c\tau+d)\xi_\tau$ . To see this, note that  $(F_A)^*$  maps  $dz$  to  $(c\tau+d)dz$ . By dualizing, the claim is established.

Now  $E(\mathbb{C}/\Lambda_\tau) = \hat{E}(\tau)\xi_\tau^{\otimes k} \in \text{Det}_{\mathbb{C}/\Lambda_\tau}^{\otimes k}$ . Assuming property (14.1), we want to show that  $\hat{E}(\tau') = (c\tau+d)^{-k}\hat{E}(\tau)$  when  $\tau' = A\tau$ . We compute

$$\begin{aligned} (F_A)_*(E(\mathbb{C}/\Lambda_{\tau'})) &= (F_A)_*(\hat{E}(\tau')\xi_{\tau'}^{\otimes k}) \\ E(\mathbb{C}/\Lambda_\tau) &= \hat{E}(\tau')(F_A)_*(\xi_{\tau'}^{\otimes k}) \\ \hat{E}(\tau)\xi_\tau^{\otimes k} &= \hat{E}(\tau')(c\tau+d)^k \xi_\tau^{\otimes k} \end{aligned}$$

from which the claim follows. The left hand side of the first two lines are equivalent by assumption of property (14.1). The equality of the right hand sides of the last two lines follows from the previous claim and the rest of the equalities are straightforward.

It is clear that each such an assignment determines such a function and also that the construction can be easily reversed. Hence the correspondence is a bijection.  $\square$

## 15. FUNCTIONS TRANSFORMING AS MODULAR FORMS: REVISITED

Let  $\Sigma$  be a smooth complex projective curve of genus 1.

**Theorem 15.1.**  *$\Sigma$  is complex analytically isomorphic to  $\mathbb{C}/\Lambda_\tau$  where  $\Lambda_\tau = \mathbb{Z} + \tau\mathbb{Z}$  for some  $\tau \in \mathfrak{h}$ .*

Thus, as a smooth manifold  $\Sigma$  is a two-dimensional torus. It is also an abelian group and therefore a homogeneous space. The presentation as  $\mathbb{C}/\Lambda_\tau$  corresponds to choosing a base point  $e \in \Sigma$  which corresponds to the unit element.

In this case, the determinant line is  $\text{Det}_\Sigma = \Omega_{\text{hol}}^1(\Sigma)^\vee$ . We will write  $\omega_\Sigma$  for  $\text{Det}_\Sigma^\vee$ . The line  $\omega_\Sigma$  can be viewed in several useful ways, either as  $\Omega_{\text{hol}}^1(\Sigma)$ , or as the holomorphic differentials on  $\mathbb{C}$  which are invariant under translation by elements of  $\Lambda_\tau$ , or as the holomorphic cotangent space at the unit element  $e$ .

We are interested in assignments of the form  $\Sigma \mapsto \varphi(\Sigma) \in \omega_\Sigma^{\otimes k}$ . These assignments should be functorial, i.e., given a base point preserving complex analytic isomorphism  $g: \Sigma' \rightarrow \Sigma$  (an isogeny in algebraic geometry language) the induced map  $g_*: \omega_{\Sigma'}^{\otimes k} \rightarrow \omega_\Sigma^{\otimes k}$  should send  $\varphi(\Sigma')$  to  $\varphi(\Sigma)$ . Recall from our previous discussions that assignments of this type are in bijection with functions  $f: \mathfrak{h} \rightarrow \mathbb{C}$

which transform as modular forms of weight  $k$ . These maps are not necessarily holomorphic, smooth, or even continuous. How do we build in analytic properties of  $f$ ?

Now is a good time for a short digression on natural transformations. If  $\mathcal{C}$  is a category and  $C, C' \in \mathcal{C}$ , write  $\mathcal{C}(C, C')$  for the set of morphisms from  $C$  to  $C'$ .

**Definition 15.2.** Let  $\mathcal{C}$  and  $\mathcal{D}$  be categories and suppose  $F: \mathcal{C} \rightarrow \mathcal{D}$  and  $G: \mathcal{C} \rightarrow \mathcal{D}$  are functors. A natural transformation  $T$ , depicted

$$\mathcal{C} \begin{array}{c} \xrightarrow{F} \\ \Downarrow T \\ \xrightarrow{G} \end{array} \mathcal{D}$$

is the assignment to each  $C \in \mathcal{C}$  of a morphism in  $T_C \in \mathcal{D}(F(C), G(C))$  such that for each morphism  $f \in \mathcal{C}(C, C')$  the following diagram commutes

$$\begin{array}{ccc} F(C) & \xrightarrow{T_C} & G(C) \\ F(f) \downarrow & & G(f) \downarrow \\ F(C') & \xrightarrow{T_{C'}} & G(C'). \end{array}$$

With this notion, we can discuss the category  $\text{Fun}(\mathcal{C}, \mathcal{D})$  whose objects are functors and whose morphisms are natural transformations between them.

**Definition 15.3.** Two categories  $\mathcal{C}$  and  $\mathcal{D}$  are equivalent if and only if there exists  $F \in \text{Fun}(\mathcal{C}, \mathcal{D})$  and  $H \in \text{Fun}(\mathcal{D}, \mathcal{C})$  such that  $F \circ H$  and  $H \circ F$  are objects in  $\text{Fun}(\mathcal{D}, \mathcal{D})$  and  $\text{Fun}(\mathcal{C}, \mathcal{C})$  which are isomorphic to the identity, respectively.

**Proposition 15.4.**  $F \in \text{Fun}(\mathcal{C}, \mathcal{D})$  is a equivalence of categories if and only if

- (1)  $F$  induces a bijection between isomorphism classes of objects in  $\mathcal{C}$  and  $\mathcal{D}$ ,  
and
- (2) for each  $C, C' \in \mathcal{C}$ ,  $F: \mathcal{C}(C, C') \rightarrow \mathcal{D}(F(C), F(C'))$  is a bijection.

There is a close relationship between this language of functors, natural transformations, and equivalences of categories, and that of maps, homotopies, and homotopy equivalences. The correspondence is obtained by taking the classifying space of a category.

Let  $\text{Tori}$  denote the groupoid whose objects are pointed complex tori and whose morphisms are base point preserving complex analytic isomorphisms. Let  $\text{Vect}_{\mathbb{C}}$  denote the category whose objects are complex vector spaces and whose morphisms are  $\mathbb{C}$ -linear maps. We will define  $\omega^{\otimes k} \in \text{Fun}(\text{Tori}, \text{Vect}_{\mathbb{C}})$  by the assignment  $\Sigma \mapsto \omega_{\Sigma}^{\otimes k}$ . Finally, let  $C \in \text{Fun}(\text{Tori}, \text{Vect}_{\mathbb{C}})$  denote the constant functor which assigns to every object  $\mathbb{C}$  and to every isomorphism the identity map on  $\mathbb{C}$ . Then the maps  $\varphi$  in which we are interested are the natural transformations

$$(15.1) \quad \text{Tori} \begin{array}{c} \xrightarrow{C} \\ \Downarrow \varphi \\ \xrightarrow{\omega^{\otimes k}} \end{array} \text{Vect}_{\mathbb{C}}.$$

Note that if  $G: \Sigma' \rightarrow \Sigma$  is an isomorphism of curves then  $G_*: \omega_{\Sigma'}^{\otimes k} \rightarrow \omega_{\Sigma}^{\otimes k}$  is an isomorphism.

Suppose  $\varphi$  is such a natural transformation, then for each  $\Sigma \in \text{Tori}$  we get a linear map  $\varphi(\Sigma): c(\Sigma) \rightarrow \omega_{\Sigma}^{\otimes k}$ . Since this map is determined by the image of

$1 \in \mathbb{C}$ , this corresponds to selecting an element of the line  $\omega_{\Sigma}^{\otimes k}$ . Furthermore, if  $G: \Sigma' \rightarrow \Sigma$  is an isomorphism of curves then the isomorphism  $G_*: \omega_{\Sigma'}^{\otimes k} \rightarrow \omega_{\Sigma}^{\otimes k}$  carries  $\varphi(\Sigma')$  to  $\varphi(\Sigma)$ .

**Corollary 15.5.** *We have a bijection between the set of natural transformations  $\varphi$  in (15.1) and functions  $f: \mathfrak{h} \rightarrow \mathbb{C}$  satisfying the transformation rule of a modular form of weight  $-k$ .*

How is the category  $\text{Tori}$  related to  $\mathfrak{h}$  and the action of  $\text{SL}(2, \mathbb{Z})$ ? There is a general construction which allows one to view a set with a group action, such as  $\mathfrak{h}$  with the action of  $\text{SL}(2, \mathbb{Z})$ , as a groupoid called the *transport groupoid*. Given a set  $X$  with an action  $G \times X \rightarrow X$  by a group  $G$ , we define a groupoid  $X/G$  by declaring the objects to be the elements of  $X$  and given  $x, y \in X$  we define the set of morphisms as  $X/G(x, y) = \{g \in G | gx = y\}$ . Composition of morphisms is then given by multiplication in  $G$ .

**Lemma 15.6.** *The transport groupoid  $\mathfrak{h}/\text{SL}(2, \mathbb{Z})$  is equivalent as a category to  $\text{Tori}$ .*

*Proof.* An object in  $\mathfrak{h}/\text{SL}(2, \mathbb{Z})$  is a point  $\tau$  in the upper half-plane. We define a functor  $\mathfrak{h}/\text{SL}(2, \mathbb{Z}) \rightarrow \text{Tori}$  by the assignment  $\tau \mapsto \mathbb{C}/\Lambda_{\tau}$  on objects and, given a  $A \in \text{SL}(2, \mathbb{Z})$  determining the morphism  $\tau \mapsto \tau' = A\tau$  in the transport groupoid, we assign the isomorphism of curves  $A_*: \mathbb{C}/\Lambda_{\tau} \rightarrow \mathbb{C}/\Lambda_{\tau'}$  given by  $[z] \mapsto [(c\tau + d)^{-1}z]$ . This functor is bijective on isomorphism classes of objects and gives an equivalence of categories.  $\square$

The real question at hand is how we will build in the analytic properties of these natural transformations. The idea, which will appear frequently in these lectures, is to work in families.

Let  $\text{Tori}^{\text{hol fam}}$  denote the category of holomorphic families of tori, i.e., the objects of this category are holomorphic fiber bundles whose fibers are tori, together with a holomorphic section of this bundle which selects a base point in each fiber. A morphism in this category is a commutative diagram

$$\begin{array}{ccc} \Sigma' & \xrightarrow{\hat{f}} & \Sigma \\ \left( \begin{array}{c} \uparrow \\ p' \\ \downarrow \end{array} \right)_{s'} & & \left( \begin{array}{c} \uparrow \\ p \\ \downarrow \end{array} \right)_s \\ S' & \xrightarrow{f} & S \end{array}$$

where  $\hat{f}$  is a fiberwise isomorphism of  $\text{Tori}$ . Analogously, we let  $\text{Vect}_{\mathbb{C}}^{\text{hol fam}}$  denote the category of holomorphic vector bundles.

*Remark 15.7.* Restricting to fiber bundles throws out the possibility of degeneration of the fibers to singular curves. Perhaps it is better to work in the world of algebraic geometry with flat morphisms.

With these family versions, we now want to systematically enhance our previous discussion. We define the constant functor  $C: \text{Tori}^{\text{hol fam}} \rightarrow \text{Vect}_{\mathbb{C}}^{\text{hol fam}}$  which assigns to the holomorphic torus bundle over  $S$  the trivial line bundle over  $S$ . By  $\omega^{\otimes k}$  we now denote the functor

$$\left( \Sigma \begin{array}{c} \xleftarrow{s} \\ \xrightarrow{p} \end{array} S \right) \quad \mapsto \quad s^*(T(\Sigma/S)) \longrightarrow S$$

where  $T(\Sigma/S)$  denotes the *complex tangent space of  $\Sigma$  over  $S$* , i.e.,  $\ker p_*$  over  $\mathbb{C}$ , the vertical part of  $T\Sigma \otimes \mathbb{C}$ .

**Proposition 15.8.** *There is a bijection between natural transformations*

$$\text{Tori}^{\text{hol fam}} \begin{array}{c} \xrightarrow{\quad \mathbb{C} \quad} \\ \Downarrow \varphi \\ \xrightarrow{\quad \omega^{\otimes k} \quad} \end{array} \text{Vect}_{\mathbb{C}}^{\text{hol fam}}$$

and holomorphic functions  $f: \mathfrak{h} \rightarrow \mathbb{C}$  which transform as modular functions of weight  $k$ .

*Proof.* Suppose  $\varphi$  is a natural transformation. Consider the “universal torus family over  $\mathfrak{h}$ ,”  $\Sigma = (\mathfrak{h} \times \mathbb{C})/\mathbb{Z}^2 \rightarrow \mathfrak{h}$ , the torus bundle over  $\mathfrak{h}$  whose fiber above  $\tau$  is  $\mathbb{C}/\Lambda_\tau$ . The group  $\mathbb{Z}^2$  acts on  $\mathfrak{h} \times \mathbb{C}$  in the obvious way,  $(\tau, z) \cdot (m, n) \mapsto (\tau, z + m \cdot 1 + n\tau)$ .

For this object  $\Sigma \in \text{Tori}^{\text{hol fam}}$ , the bundle  $\omega^{\otimes k}(\Sigma)$  is trivialized as  $\mathfrak{h} \times \mathbb{C}$  by  $(\tau, 1) \mapsto (dz)^{\otimes k}$ . Thus

$$\begin{array}{ccc} c(\Sigma) = \mathfrak{h} \times \mathbb{C} & \xrightarrow{\varphi(\Sigma)} & \omega^{\otimes k}(\Sigma) = \mathfrak{h} \times \mathbb{C} \\ & \searrow & \swarrow \\ & \mathfrak{h} & \end{array}$$

$\varphi(\Sigma)$  is a bundle map  $\mathfrak{h} \times \mathbb{C} \rightarrow \mathfrak{h} \times \mathbb{C}$  and thus can be identified with a holomorphic function on  $\mathfrak{h}$ . This assignment turns out to be bijective.  $\square$

A final question to ask is whether or not we can pin down the behavior at  $i\infty$ . This is for the moment unclear. What about integrality of the modular functions? More on this later.

## 16. VECTOR BUNDLES OVER CATEGORIES

The goal for today is to develop some language that we will need to pin down the properties of the natural transformations which correspond to integral modular forms.

Let  $\text{Man}_{\mathbb{C}}$  denote the category of complex manifolds and holomorphic maps between them. The first thing to note is that there are forgetful functors

$$\begin{array}{ccc} \text{Tori}^{\text{hol fam}} & & \text{Vect}_{\mathbb{C}}^{\text{hol fam}} \\ & \searrow & \swarrow \\ & \text{Man}_{\mathbb{C}} & \end{array}$$

which return the base space of the corresponding bundle. What properties do these functors have?

**Definition 16.1.** Let  $\rho: \mathcal{C} \rightarrow \mathcal{S}$  be a functor, then  $f \in \mathcal{C}(c, d)$  is said to be *cartesian* if for each  $b \in \mathcal{C}$  and morphisms  $h \in \mathcal{C}(b, d)$ ,  $\bar{g} \in \mathcal{S}(\rho(b), \rho(d))$  making the diagram

$$\begin{array}{ccccc}
 b & & & & \\
 \rho \downarrow & \nearrow \exists! g & h & & \\
 \rho(b) & & c & \xrightarrow{f} & d \\
 & \searrow \bar{g} & \rho \downarrow & & \rho \downarrow \\
 & & \rho(c) & \xrightarrow{\bar{f}} & \rho(d)
 \end{array}$$

commute, there exists a unique  $g \in \mathcal{C}(b, c)$  making the diagram commute.

It is important to note that the definition of cartesian morphism depends strongly on the functor  $\rho$ . For example, let  $\mathcal{C}$  be the category of vector bundles and let  $\mathcal{S}$  be the category of topological spaces. Let  $\rho$  be the forgetful functor from  $\mathcal{C}$  to  $\mathcal{S}$  which returns the base space of the given bundle. A morphism in  $\mathcal{C}$  is a commutative diagram

$$\begin{array}{ccc}
 E & \xrightarrow{f} & E' \\
 \downarrow & & \downarrow \\
 S & \xrightarrow{\bar{f}} & S'
 \end{array}$$

where  $\bar{f}$  is linear on the fibers. If  $f$  is a fiber-wise isomorphism, then we have the following universal property: Given such a commutative diagram and a bundle  $F \rightarrow R$  with a map  $\bar{g}: R \rightarrow S$  and a fiber-wise isomorphism  $h: F \rightarrow E'$  covering  $\bar{f} \circ \bar{g}$ , there exists a unique fiber-wise isomorphism  $g: F \rightarrow E$  making the diagram

$$\begin{array}{ccccc}
 F & & & & \\
 \downarrow & \nearrow \exists! g & h & & \\
 R & & E & \xrightarrow{f} & E' \\
 & \searrow \bar{g} & \downarrow & & \downarrow \\
 & & S & \xrightarrow{\bar{f}} & S'
 \end{array}$$

commute. So the cartesian morphisms in the category of vector bundles with respect to the functor  $\rho$  are the fiber-wise isomorphisms. Similarly, the cartesian morphisms in  $\text{Tori}^{\text{hol fam}}$  are the bundle maps which are fiber-wise biholomorphisms of tori.

**Definition 16.2.** A functor  $\rho: \mathcal{C} \rightarrow \mathcal{S}$  is a Grothendieck fibration if and only if for each  $\bar{f} \in \mathcal{S}(S, S')$  and  $E' \in \mathcal{C}$  with  $\rho(E') = S'$  there exists a cartesian morphism  $f \in \mathcal{C}(E, E')$  making the diagram

$$\begin{array}{ccc}
 E & \xrightarrow{f} & E' \\
 \rho \downarrow & & \downarrow \rho \\
 S & \xrightarrow{\bar{f}} & S'
 \end{array}$$

commute.

An idea to remember is that Grothendieck fibrations encode pull-backs. Some examples are the forgetful functors from vector bundles to topological spaces, holomorphic vector bundles to complex manifolds,  $\text{Tori}^{\text{hol fam}}$  to  $\text{Man}_{\mathbb{C}}$ .

Roughly speaking, a Grothendieck fibration  $\mathcal{C} \rightarrow \mathcal{S}$  is called a stack if you can “glue objects in  $\mathcal{C}$ .” For example, the category of vector bundles over topological spaces is a stack. To develop this further one needs a categorical generalization of open covers. This is the data in a Grothendieck topology.

**Definition 16.3.** A vector bundle over  $\text{Tori}^{\text{hol fam}}$  is a functor  $F: \text{Tori}^{\text{hol fam}} \rightarrow \text{Vect}_{\mathbb{C}}^{\text{hol fam}}$  such that

- i)  $F$  commutes with the forgetful functors to  $\text{Man}_{\mathbb{C}}$ ,

$$\begin{array}{ccc} \text{Tori}^{\text{hol fam}} & \xrightarrow{F} & \text{Vect}_{\mathbb{C}}^{\text{hol fam}} \\ & \searrow & \swarrow \\ & \text{Man}_{\mathbb{C}} & \end{array}$$

and

- ii)  $F$  carries cartesian morphisms to cartesian morphisms.

Another way to think about this definition is that  $F$  gives a functorial way to make a holomorphic vector bundle over  $S$  out of a holomorphic family of tori over  $S$ . Let  $C: \text{Tori}^{\text{hol fam}} \rightarrow \text{Vect}_{\mathbb{C}}^{\text{hol fam}}$  denote the constant functor which assigns to each holomorphic torus bundle over  $S$ , the trivial line bundle over  $S$ .

**Definition 16.4.** A *section*  $\varphi$  of a vector bundle  $F$  over  $\text{Tori}^{\text{hol fam}}$  is a natural transformation  $\varphi: C \Rightarrow F$ ,

$$\text{Tori}^{\text{hol fam}} \begin{array}{c} \xrightarrow{C} \\ \Downarrow \varphi \\ \xrightarrow{F} \end{array} \text{Vect}_{\mathbb{C}}^{\text{hol fam}}.$$

In order to head towards a geometric viewpoint on integral modular forms, we now systematically replace analytic categories with arithmetic categories. The category  $\text{Man}_{\mathbb{C}}$  is replaced with the category of schemes over  $\text{Spec } \mathbb{Z}$ . The category  $\text{Tori}^{\text{hol fam}}$  is replaced by the category whose objects are flat families of elliptic curves over schemes over  $\text{Spec } \mathbb{Z}$ . And  $\text{Vect}_{\mathbb{C}}^{\text{hol fam}}$  is replaced with the category of locally free coherent sheaves of  $\mathcal{O}_S$ -modules where  $S$  is a scheme over  $\text{Spec } \mathbb{Z}$ .

Briefly, here is what we need to know about schemes. Let  $R$  be a commutative ring<sup>10</sup>. By  $\text{Spec } R$  we denote the set of prime ideals in  $R$  equipped with the Zariski topology. A basis of open sets for this topology are the sets  $D_t = \{\text{prime ideals } \mathfrak{p} : t \notin \mathfrak{p}\}$  for each  $t \in R$ . Over this topological space is a sheaf  $\mathcal{O}_{\text{Spec } R}$  whose value on the open set  $D_t$  the localization of  $R$  at  $t$ . The data  $(\text{Spec } R, \mathcal{O}_{\text{Spec } R})$  is called an *affine scheme*.

**Definition 16.5.** A *scheme* is a pair  $(X, \mathcal{O}_X)$  where  $X$  is a topological space and  $\mathcal{O}_X$  is a sheaf such that  $(X, \mathcal{O}_X)$  is locally isomorphic to  $(\text{Spec } R, \mathcal{O}_{\text{Spec } (R)})$  for some  $R$ .

**Definition 16.6.** An *elliptic curve* over a base scheme  $S$  is a morphism of schemes  $\rho: E \rightarrow S$ , smooth and proper, having genus 1 curves as fibers, together with a section  $s: S \rightarrow E$  of  $\rho$ .

<sup>10</sup>We will always assume that rings have 1.

As discussed in [KM] and [D], one can form a category  $Ell$  of elliptic curves over schemes  $S$  along with two functors  $\rho: Ell \rightarrow Schemes$  and  $e: Schemes \rightarrow Ell$ , the first being the forgetful functor which returns the base scheme and the second a section of  $\rho$ , generalizing the base point selection section. The functor  $\rho$  is a Grothendieck fibration. When  $Schemes$  is equipped with the étale topology, then

$$Ell \xrightarrow{\rho} Schemes$$

can be interpreted as a stack.

Over this stack, we will consider a line bundle  $\omega$  and its tensor powers. Of course, this needs a categorical definition. Here  $\omega$  is a functor making the diagram

$$\begin{array}{ccc} Ell & \xrightarrow{\omega} & LFSheaves \\ & \searrow \rho & \swarrow \\ & Schemes & \end{array}$$

commute. Given  $E \rightarrow S$ , an elliptic curve over  $S$ , we define  $\omega(E \rightarrow S)$  by  $e^*(T^*(E/S))$  where  $T^*(E/S)$  is our notation for the cotangent space of  $E$  over  $S$ . Each point in the image of  $e$  is smooth, so there is a notion of tangent space and its dual at that point.

Next time we will define sections of  $\omega^{\otimes k}$  as natural transformations between certain functors and try to indicate why there is a correspondence between sections of  $\omega^{\otimes k}$  and integral modular forms. The fact that the moduli space of elliptic curves has a compactification which includes only nodal curves (Deligne-Mumford compactification) is what leads to the  $q$ -series of the modular form having no pole at zero. The integrality enters through the fact that we are considering all schemes. Since  $\mathbb{Z}$  maps to every ring, considering only results that work over all rings after base change is where the integrality of the  $q$ -series enters in.

## 17. WEIERSTRASS CURVES AND THE MODULI STACK $\overline{\mathcal{M}}$

Today's goal is to give a geometric description of integral modular forms so that later we can extend to the description of topological modular forms. Recall that we established a bijection between holomorphic functions  $f: \mathfrak{h} \rightarrow \mathbb{C}$  which transform as modular form of weight  $k$  and natural transformations  $\varphi$  between the constant functor  $C$  and the functor  $\omega^{\otimes k}$  between  $\text{Tori}^{\text{hol fam}}$  and  $\text{Vect}_{\mathbb{C}}^{\text{hol fam}}$ .

Since we are heading in the direction of algebraic geometry, we now adopt the usual practice of intentionally confusing vector bundles with their sheaf of sections. Recall that an object in  $\text{Tori}^{\text{hol fam}}$  is a holomorphic fiber bundle  $\rho: E \rightarrow S$  whose fibers are complex elliptic curves together with a section  $e: S \rightarrow E$  selecting a base point in each fiber. The functor  $\omega$  assigns to such an object a certain complex line bundle over  $S$ ,  $\omega(E)$ , whose fiber over  $s \in S$  is the sheaf of invariant differentials on  $E|_s$ , i.e.,  $\omega(E) = e^*(\Omega_{E/S}^1)$ .

Given a lattice  $\Lambda \subset \mathbb{C}$ , how can we describe  $\mathbb{C}/\Lambda$  as a curve in  $\mathbb{CP}^2$ ? It is the zero locus of a homogeneous polynomial. What is its degree? This question is answered by the degree-genus formula. Here is a topologist's version of the proof.

**Proposition 17.1** (Degree-Genus Formula). *Let  $f \in \mathbb{C}[z_0, z_1, z_2]$  be homogeneous of degree  $d$ , set*

$$X_d = \{[z_0 : z_1 : z_2] : f(z_0, z_1, z_2) = 0\},$$

and assume that  $X_d$  is a smooth irreducible subvariety of  $\mathbb{CP}^2$ . Then  $X_d$  is a smooth curve of genus

$$g = \frac{(d-1)(d-2)}{2}.$$

*Proof.* The Euler characteristic  $\chi(X_d) = 2 - 2g$ , where  $g$  is the genus, can be computed by evaluating the first Chern class  $c_1(TX_d)$  on the fundamental class  $[X_d]$ .

Over  $\mathbb{CP}^2$  there is a natural line bundle

$$H = \{(L, v) : L \in \mathbb{CP}^2, v \in L\} \subset \mathbb{CP}^2 \times \mathbb{C}^3 = \underline{\mathbb{C}}^3.$$

In topology, this is referred to as the Hopf line bundle over projective space. In algebraic geometry it is referred to as the tautological line bundle over projective space. Let  $H^\perp$  denote the orthogonal complement of  $H$  in  $\underline{\mathbb{C}}^3$ , then  $T\mathbb{CP}^2 \simeq \text{Hom}(H, H^\perp)$ .<sup>11</sup> Note that the first Chern class remains unchanged if we add a trivial bundle. Fortunately,

$$\begin{aligned} T\mathbb{CP}^2 \oplus \underline{\mathbb{C}} &\simeq \text{Hom}(H, H^\perp) \oplus \text{Hom}(H, H) \\ &\simeq \text{Hom}(H, H^\perp \oplus H) \\ &\simeq \text{Hom}(H, \underline{\mathbb{C}}^3) \\ &\simeq 3H^\vee \end{aligned}$$

so we can express the total Chern class of  $T\mathbb{CP}^2$  easily in terms of the generator  $x = c_1(H^\vee)$  for  $H^\bullet(\mathbb{CP}^2) \simeq \mathbb{Z}[x]/(x^3)$ .

Now, the homogeneous polynomial  $f$  determines a global section  $\hat{f}: \mathbb{CP}^2 \rightarrow (H^\vee)^{\otimes d} \simeq \text{Hom}(H^{\otimes d}, \mathbb{C})$  by sending  $[z_0 : z_1 : z_2]$  to the form  $(z_0, z_1, z_2)^{\otimes d} \mapsto f(z_0, z_1, z_2)$ . The curve  $X_d$  is then the zero locus of this section in  $\mathbb{CP}^2$ . Our assumption that  $X_d$  is smooth implies that  $\hat{f}$  is transverse to the zero section which implies that the normal bundle  $\nu(X_d, \mathbb{CP}^2) = (H^\vee)^{\otimes d}|_{X_d}$ .

Recall that the total Chern class is exponential. Hence,  $c(TX_d)$  equals

$$\begin{aligned} c(T\mathbb{CP}^2|_{X_d} - \nu) &= c(T\mathbb{CP}^2)c(\nu)^{-1} \\ &= c(3H^\vee)c((H^\vee)^{\otimes d})^{-1}. \end{aligned}$$

In terms of the generator  $x$ , we have

$$\begin{aligned} c(TX_d) &= (1+x)^3(1+dx)^{-1} \\ &= 1+3x-dx+\mathcal{O}(x^2) \\ &= 1+(3-d)x \end{aligned}$$

where the terms of order higher order terms vanish because  $X_d$  has dimension 1.

The class  $[X_d]$  in  $H^\bullet(\mathbb{CP}^2)$  is  $d[\mathbb{CP}^1]$ . Thus

$$\begin{aligned} \chi(X_d) &= \langle c_1(TX_d), [X_d] \rangle \\ &= \langle (3-d)x, d[\mathbb{CP}^1] \rangle \\ 2-2g &= (3-d)d \end{aligned}$$

and thus  $2g = d^2 - 3d + 2 = (d-1)(d-2)$ . The degree-genus formula is then obtained by dividing both sides by 2.  $\square$

<sup>11</sup>This is a general fact about Grassmann manifolds which one can learn from [MS] for example.

It follows from the degree-genus formula that the degree of a genus one curve can only be 3. So, given our manifold  $\mathbb{C}/\Lambda_\tau$ , we need a method of producing a cubic equation. This was worked out by Weierstrass and involves the following function.

Given a lattice  $\Lambda \subset \mathbb{C}$ , we define the *Weierstrass p-function*  $\wp: \mathbb{C} \rightarrow \mathbb{C}$  by the series

$$\wp(z) = \frac{1}{z^2} + \sum_{\omega \in \Lambda \setminus \{0\}} \left( \frac{1}{(z-\omega)^2} - \frac{1}{\omega^2} \right).$$

The function  $\wp(z)$  is a meromorphic function with poles at the points of  $\Lambda$  and is periodic with respect to  $\Lambda$ . The following theorem gives us the relationship between the tori  $\mathbb{C}/\Lambda_\tau$  and genus one curves in  $\mathbb{CP}^2$ .

**Theorem 17.2** (Weierstrass). *The map  $\mathbb{C}/\Lambda \rightarrow \mathbb{CP}^2$  defined by  $[z] \mapsto [\wp(z) : \wp'(z) : 1]$  for  $[z] \neq 0$  and  $[0] \mapsto [0 : 1 : 0]$  is a holomorphic embedding of  $\mathbb{C}/\Lambda$  into  $\mathbb{CP}^2$ . The image of this embedding is a curve given by the equation*

$$y^2 = 4x^3 - g_2(\Lambda)x - g_3(\Lambda)$$

where  $x = z_0/z_2$  and  $y = z_1/z_2$  where  $z_2 \neq 0$  and

$$g_2(\Lambda) = 60 \sum_{\omega \in \Lambda \setminus \{0\}} \omega^{-4} \text{ and } g_3(\Lambda) = 140 \sum_{\omega \in \Lambda \setminus \{0\}} \omega^{-6}.$$

Let  $R$  be a commutative ring.

**Definition 17.3.** A *Weierstrass curve* over  $R$  is the curve in  $\mathbb{P}_R^2$  given by the equation

$$(17.1) \quad y^2 + a_1xy + a_3y = x^3 + a_2x^2 + a_4x + a_6$$

where  $a_1, a_2, a_3, a_4, a_6 \in R$ .

The curve is smooth if the *discriminant*  $\Delta(a_1, a_2, a_3, a_4, a_6) \in R^\times$ . For a given ring  $R$ , the Weierstrass equation can be simplified to look like the form over  $\mathbb{C}$  if  $2, 3 \in R^\times$ . The equation in (17.1) is the most general equation of a cubic curve in  $\mathbb{P}_R^2$  up to an automorphism of  $\mathbb{P}_R^2$ .

Isomorphisms between Weierstrass curves are given by projective linear transformations of  $\mathbb{P}_R^2$  mapping one Weierstrass curve to another. Explicitly, such transformations have the form

$$x \mapsto \lambda^{-2}x + r, \quad y \mapsto \lambda^{-1}y + \lambda^{-1}sx + t$$

for  $\lambda \in \mathbb{R}^\times$  and  $r, s, t \in R$ .

Our goal now is to describe an analog  $\mathcal{M} \rightarrow \text{Aff}$  of the Grothendieck fibration  $\text{Tori}^{\text{hol fam}} \rightarrow \text{Man}_{\mathbb{C}}$ . The objects of the category  $\mathcal{M}$  are pairs  $(R, C)$  where  $R$  is a commutative ring and  $C$  is a Weierstrass curve over  $R$ . By forgetting the curve and remembering  $R$ , or equivalently, the affine scheme  $\text{Spec}(R)$  we obtain a map on objects between  $\mathcal{M}$  and the category of affine schemes  $\text{Aff}$ . The morphisms of  $\mathcal{M}$  are generated by the isomorphisms of Weierstrass curves and base-change morphisms. The Grothendieck fibration  $\mathcal{M} \rightarrow \text{Aff}$  is called the moduli stack of elliptic curves because it has the stack property with respect to the Grothendieck topology on  $\text{Aff}$ . We will not establish this here.

A morphism  $\text{Spec}(R') \rightarrow \text{Spec}(R)$  is equivalent to a ring homomorphism  $f: R \rightarrow R'$ . Using fiber products, we can pull-back a Weierstrass curve  $C$  over  $R$  to a Weierstrass curve  $C'$  over  $R'$ . In terms of equations, this amounts to replacing the coefficients in  $R$  of the equation for  $C$  with their images under  $f: R \rightarrow R'$ .

Geometrically, we can think of an object in  $\mathcal{M}$  also as a sheaf of Weierstrass curves. Suppose  $(R, C)$  is an object of  $\mathcal{M}$ . Over the open set  $D_t = \{\text{prime ideals } \mathfrak{p} \mid t \notin \mathfrak{p}\}$ ,  $t \in R$ , we obtain a curve  $E(D_t)$  over  $R[t^{-1}]$  by changing coefficients under the map  $R \rightarrow R[1/t]$ .

### 18. INTEGRAL MODULAR FORMS AS SECTIONS OVER $\overline{\mathcal{M}}$

Last time we discussed the stack  $\mathcal{M} \rightarrow \text{Aff}$  of generalized smooth elliptic curves. By  $\overline{\mathcal{M}} \rightarrow \text{Aff}$  we mean the same thing including singular degenerations of smooth curves. The base of this Grothendieck fibration is the category of affine schemes, or equivalently, the opposite of the category of commutative rings (with 1). Other flavors of this construction are possible, allowing only certain kinds of singular curves for example, or considering generalized elliptic curves over general schemes instead of just affine schemes.

One should think of  $\overline{\mathcal{M}} \rightarrow \text{Aff}$  as analogous to  $\text{Tor}^{\text{hol fam}} \rightarrow \text{Cman}$ . What do we mean by a vector bundle over  $\overline{\mathcal{M}}$ ? How do we think of a section of such a bundle?

Let  $\text{Mod}$  denote the category whose objects are pairs  $(R, M)$  where  $R$  is a commutative ring and  $M$  is an  $R$ -module. Then there is a forgetful functor  $\text{Mod} \rightarrow \text{Aff}$  which sends  $(R, M)$  to  $\text{Spec } R$ . From the algebraic geometry perspective, vector bundles over manifolds correspond to locally free coherent sheaves of modules over the structure sheaf of the base scheme.

**Definition 18.1.** A *sheaf*  $E$  over  $\overline{\mathcal{M}}$  is a functor

$$\begin{array}{ccc} \overline{\mathcal{M}} & \xrightarrow{E} & \text{Mod} \\ & \searrow & \swarrow \\ & \text{Aff} & \end{array}$$

making the above diagram commute, which carries cartesian morphisms to cartesian morphisms. If  $E$  maps to free modules, then we say that that  $E$  is a vector bundle.

Let  $C: \overline{\mathcal{M}} \rightarrow \text{Mod}$  denote the constant functor which assigns to every object  $(R, C)$  in  $\overline{\mathcal{M}}$  the object  $(R, R)$  where the  $R$  in the second slot the ring viewed as a module over itself.

**Definition 18.2.** A *section* of a vector bundle  $E: \overline{\mathcal{M}} \rightarrow \text{Mod}$  is a natural transformation

$$\begin{array}{ccc} \overline{\mathcal{M}} & \begin{array}{c} \xrightarrow{C} \\ \Downarrow \varphi \\ \xrightarrow{E} \end{array} & \text{Mod}. \end{array}$$

Now we can describe the construction of a line bundle  $\omega$  over  $\overline{\mathcal{M}}$  analogous to that with the same name over  $\text{Tor}^{\text{hol fam}}$ . To an object  $X = (R, C)$  in  $\overline{\mathcal{M}}$  we associate the rank one free  $R$ -module

$$\omega_X = R \left[ \frac{dx}{2y + a_1x + a_3} \right].$$

The key point is that isomorphisms of Weierstrass curves preserve the form of the differential up to a multiplication by an invertible element of  $R$ . So an isomorphism of curves  $X \rightarrow X'$  gives rise to an interesting morphism  $\omega_X \rightarrow \omega_{X'}$ . Since the morphisms of  $\overline{\mathcal{M}}$  are generated by isomorphisms of Weierstrass curves and base-change morphisms, this indicates that  $\omega: \overline{\mathcal{M}} \rightarrow \text{Mod}$  is a non-trivial line bundle

over  $M$ . Its  $k^{\text{th}}$  tensor power  $\omega^{\otimes k}$  is defined by assigning to  $X$  the free rank one module  $\omega_X^{\otimes k}$ .

**Proposition 18.3.** *The sections of  $\omega^{\otimes k}$  over  $\overline{\mathcal{M}}$  are in bijection with the integral modular forms of weight  $k$ .*

Before, we considered only smooth curves and thus could not account for the analytic behavior of the associated modular form at  $i\infty$ . But here, we work with a compactification  $\overline{\mathcal{M}}$  of the moduli space which contains this point, and since a section has a definite value there, it implies that the associated modular form has no pole there. This is the idea anyway.

**Topological Modular Forms.** The slogan of the subject is “There exists a sheaf  $\mathcal{O}_{\text{tmf}}$  of  $E^\infty$ -ring spectra over  $\overline{\mathcal{M}}$  such that a)  $\pi_{2k}\mathcal{O}_{\text{tmf}} \simeq \omega^{\otimes k}$  as a sheaf and b)  $\text{tmf} = \Gamma(\overline{\mathcal{M}}, \mathcal{O}_{\text{tmf}})$  as a spectrum.” Perhaps next time, we will describe how a ring spectrum determines a multiplicative generalized cohomology theory and vice versa.

The homotopy groups of the spectrum are  $\pi_{2k}\text{tmf} = \pi_{2k}\Gamma(\overline{\mathcal{M}}, \mathcal{O}_{\text{tmf}})$ . If the global section functor was exact, one could commute the functors  $\pi_{2k}$  and  $\Gamma$  and obtain the sheaf of groups  $\Gamma(\overline{\mathcal{M}}, \pi_{2k}\mathcal{O}_{\text{tmf}}) = \Gamma(\overline{\mathcal{M}}, \omega^{\otimes k})$  which is the abelian group of integral modular forms of weight  $k$ . But, this is not quite the case since interesting torsion information is lost in the process and so  $\pi_{2k}\text{tmf}$ , which gives the coefficients of the corresponding generalized cohomology theory, contains more than just the integral modular forms of weight  $k$ . The deviation from exactness of  $\Gamma$  is measured by sheaf cohomology. There exists a spectral sequence whose  $E_2$ -term is  $H^s(\overline{\mathcal{M}}, \omega^{\otimes k})$  which converges to  $\pi_{2k-s}\text{tmf}$ .

Of course, we now have a number of new terms to define and make sense of and we will do this mostly next time. Let us first recall the wedge and smash product of pointed topological spaces. Let  $X$  and  $Y$  be pointed topological spaces with base points  $x$  and  $y$ , respectively. Then, the wedge product is defined by

$$X \vee Y = (X \amalg Y)/x \sim y$$

and the usual example is that the wedge of two circles is the figure 8. The smash product is defined by

$$X \wedge Y = (X \times Y)/(x \times Y \cup X \times y)$$

and the typical example is  $S^n \wedge S^m \simeq S^{n+m}$ .

**Definition 18.4 (Naïve Version).** A *spectrum*  $E$  is a sequence  $E_n$  of pointed topological spaces and continuous maps of pointed spaces  $\epsilon_m: S^1 \wedge E_n \rightarrow E_{n+1}$ .

The maps  $\epsilon_m$  are alternatively defined as continuous pointed maps  $E_n \rightarrow \Omega E_{n+1}$  where the target is the based loop space of  $E_{n+1}$ . The space  $S^1 \wedge E_n$  for each  $n$  is also called the reduced suspension of  $E_n$ .

## 19. THE ROAD TO tmf: SPECTRA AND GCT'S

**Theorem 19.1 (Hopkins-Miller, Lurie (Rough Version)).** *There exists a sheaf of  $E^\infty$ -ring spectra  $\mathcal{O}_{\text{tmf}}$  over the stack  $\overline{\mathcal{M}}$  of (generalized) elliptic curves such that*

- a)  $\pi_{2k}\mathcal{O}_{\text{tmf}} = \omega^{\otimes k}$  (as sheaves of abelian groups)
- b)  $\pi_{2k+1}\mathcal{O}_{\text{tmf}} = 0$

and other properties...

Okay, what does all of that mean? Recall that an object of  $\overline{\mathcal{M}}$  is a pair  $(R, C)$  where  $R$  is a commutative ring and  $C$  is a Weierstrass curve over  $\text{Spec } R$  together with the forgetful map to  $\text{Spec } R$ . The sheaf  $\mathcal{O}_{\text{tmf}}$  assigns to this object a sheaf of  $E^\infty$ -ring spectra over  $\text{Spec } R$ . By taking global sections of this sheaf, one obtains an  $E^\infty$ -ring spectrum  $E_C$ . The homotopy groups of this spectrum are  $\pi_{2k} E_C = \omega^{\otimes k}$ , where  $\omega$  is a free rank one  $R$ -module, and  $\pi_{2k+1} E_C = 0$ .

Last time we discussed a naïve definition of a spectrum as a sequence of pointed spaces  $E_k$  and pointed maps  $\epsilon_k: S^1 \wedge E_k \rightarrow E_{k+1}$ . Every spectrum determines a generalized homology theory

$$\begin{aligned} \text{Top} &\rightarrow \text{AbGroups} \\ X &\mapsto E_n(X) \end{aligned}$$

for finite  $CW$ -complexes (e.g. compact manifolds), and a generalized cohomology theory

$$\begin{aligned} \text{Top}^{\text{op}} &\rightarrow \text{AbGroups} \\ X &\mapsto E^n(X) \end{aligned}$$

defined by  $E_n(X) = \pi_n(E \wedge X_+)$  and  $E^n(X) = [X_+, S^n \wedge E]$ , respectively. Of course, this notation also needs some explanation.

**Definition 19.2.** If  $E$  is a spectrum and  $X$  is a topological space then  $E \wedge X_+$  is again a spectrum with  $(E \wedge X_+)_k = E_k \wedge X_+$  and maps  $\epsilon_k \wedge \text{id}$ .

There is a natural map induced between the homotopy groups  $\pi_{n+k}(E_k)$  and  $\pi_{n+k+1}(E_{n+1})$  for each  $k$  and  $n$  through the composition

$$\pi_{n+k}(E_k) \xrightarrow{\Sigma} \pi_{n+k+1}(S^1 \wedge E_k) \xrightarrow{(\epsilon_k)_*} \pi_{n+k+1}(E_{k+1})$$

of the suspension map followed by the map on homotopy induced by  $\epsilon_k$ .

**Definition 19.3.** If  $E$  is a spectrum, then the homotopy groups of  $E$  are defined by the direct limits

$$\pi_n(E) = \varinjlim (\cdots \rightarrow \pi_{n+k}(E_k) \rightarrow \pi_{n+k+1}(E_{k+1}) \rightarrow \cdots)$$

for each  $n$ .

As bizarre as this looks, the computation of these limits is usually simpler than straight homotopy. The taking of these limits is also essential to ensure that you get a homology theory.

**Definition 19.4.** If  $E$  is spectrum and  $X$  is a pointed space, then the homotopy classes of maps  $X \rightarrow E$  is defined by

$$[X, E] := \varinjlim (\cdots \rightarrow [S^k \wedge X, E_k] \rightarrow [S^{k+1} \wedge X, E_k] \rightarrow \cdots)$$

where in the sequence we consider homotopy classes of maps between pointed spaces.

This also needs some explanation. From a map  $f: S^k \wedge X \rightarrow E_k$  we obtain a map  $\text{id} \wedge f: S^1 \wedge S^k \wedge X \rightarrow S^1 \wedge E_k$ . Now  $S^1 \wedge S^k = S^{k+1}$  and thus by post-composition with  $\epsilon_k$  we obtain a map  $S^{k+1} \wedge X \rightarrow E_k$ . Note that, in the world of spectra, the Freudenthal map  $[X, E] \rightarrow [S^1 \wedge X, S^1 \wedge E]$  is an isomorphism.

Eilenberg-MacLane spaces can be put together in a spectrum and the associated cohomology theory is ordinary cohomology. Using the spectrum  $\cdots \rightarrow BU \rightarrow U \rightarrow$

$BU \rightarrow U \rightarrow \dots$  involving the infinite unitary group and its classifying space, one obtains  $K$ -theory.

**Theorem 19.5** (Brown's Representation Theorem). *Every generalized cohomology theory satisfying the Eilenberg-Steenrod axioms comes from a spectrum and this spectrum is unique up to homotopy equivalence of spectra.*

Given this result, it is easy in topology to not distinguish between spectra and the GCT they determine or vice versa.

What properties does a spectrum  $E$  need to have in order that the associated generalized cohomology theory  $E^*$  has a (graded commutative) cup product? Well, not surprisingly, such spectra are called *ring spectra* or, more commonly,  $E_\infty$ -ring spectra.

To discuss these objects we will need a notion of maps between spectra  $\mu: E \wedge E \rightarrow E$  which should be associative and induce a graded commutative product in cohomology. Of course, to do that, we would need to define the smash product of spectra  $E \wedge E$ , but this is quite subtle and is best described using categorical language which would take more time to develop than we have available here. The common term is old terminology from before the invention of a suitable category of spectra and smash products. In the new language, spectra form symmetric monoidal category with respect to the smash product of spectra and an  $E_\infty$ -ring spectrum is commutative monoidal object in that category. The old version was quite a mess but was in some ways more concrete. The new version organizes the details in a nicer way and hides the difficulties away in category theory. Using the new version is like driving a well designed car whereas the old version was like operating a jalopy.

Here is how one defines the cup product  $\cup: E^m(X) \otimes E^n(X) \rightarrow E^{n+m}(X)$  knowing the multiplication map  $\mu$  on  $E$ . A homogeneous element of the tensor product is represented by a tensor product of classes represented by maps  $f: X_+ \rightarrow S^m \wedge E$  and  $g: X_+ \rightarrow S^n \wedge E$ , respectively. The following diagram commutes.

$$\begin{array}{ccc} X_+ \wedge X_+ & \xrightarrow{f \wedge g} & S^m \wedge E \wedge S^n \wedge E \\ \Delta \uparrow & & \downarrow \text{id} \wedge \mu \\ X_+ & \longrightarrow & S^{m+n} \wedge E \end{array}$$

We define the cup product of the classes of the maps  $f$  and  $g$  to be the class of the map at the base of this diagram.

We mention this cup product structure because this is where the data of the elliptic curve enters in tmf. Recall the general fact that  $E^{-n}(\text{pt}) = \pi_n(E) = E_n(\text{pt})$  for the generalized cohomology theory coming from a spectrum  $E$ . In tmf, we obtain one spectrum  $E_C$  for each pair  $(R, C)$  where  $R$  is a commutative ring and  $C$  is a Weierstrass curve over  $R$ . The associated GCT has  $E_C^{-2k+1}(\text{pt}) = 0$  and  $E_C^{-2k}(\text{pt}) = \omega_C^{\otimes k}$  for each  $k \in \mathbb{Z}$ . Since  $\omega_C$  is a free  $R$ -module of rank one, we can choose a generator  $u_C \in \omega_C^{-1} \simeq E^2(\text{pt})$  and with this choice there is an isomorphism of graded rings  $E_C^*(\text{pt}) \simeq R[u_C, u_C^{-1}]$ .

It is a fact that

$$E_C^*(\mathbb{C}P^\infty) \simeq E_C^*[[x]]$$

where  $x \in E_C^0(\mathbb{C}P^\infty)$ . The element  $x$  is the usual generator of the cohomology of  $\mathbb{C}P^\infty$  in degree 2, but multiplied by  $u_C^{-1}$  so as to be in degree 0. (Note, the

coefficient ring  $E_C^*$  is graded which is why the generator of the power series ring  $E_C[[x]]$  can be taken in any degree.) A second fact that we will state is that

$$E_C^*(\mathbb{C}P^\infty \times \mathbb{C}P^\infty) \simeq E_C^*[[x, y]].$$

Both of these facts can be proven using the Atiyah-Hirzebruch spectral sequence. The second isomorphism will help us to describe the cup product, but we will do this next time.

## 20. tmf AND ELLIPTIC COHOMOLOGY

Recall that  $\mathcal{O}_{\text{tmf}}$  is a sheaf of  $E_\infty$ -ring spectra over  $\overline{\mathcal{M}}$ , the stack of (generalized) elliptic curves. In more concrete terms, given a pair  $(R, C)$  where  $R$  is a commutative ring and  $C$  is a Weierstrass curve over  $R$ , one can associate an  $E_\infty$ -ring spectrum  $E_C$  such that  $\pi_{2k+1}E_C = 0$  and  $\pi_{2k}E_C = \omega^{\otimes k}$  for each  $k \in \mathbb{Z}$ . So

$$\pi_*E_C \simeq \bigoplus_{k \in \mathbb{Z}} \omega^{\otimes k} \simeq R[u_C, u_C^{-1}]$$

where  $u_C \in \omega = \pi_2E_C$ . The isomorphisms above are ring isomorphisms where  $k \in \mathbb{Z}$  in the direct sum corresponds to  $2k$  in the argument of the homotopy functor. (If you are unaccustomed to looking at expressions of this type, you might be thrown by the fact that the left hand side contains  $\pi_{-17}E_C$  for example. Recall that the homotopy groups of a spectrum are defined by limits so that while  $\pi_{-17}$  has no definition for a topological space, it does for spectra.)

The key point we would like to make is that the dependence of this information on the pair  $(R, C)$  is functorial. And, since we have a functorial way of producing a multiplicative generalized cohomology theory from a ring spectrum, we have by composition a functorial assignment  $(R, C) \mapsto E_C \mapsto E_C^*(\cdot)$ . The fundamental properties of these GCT's are

- i)  $E_C^*(\text{pt}) \simeq R[u_C, u_C^{-1}]$  where the degree of  $u_C$  is -2.
- ii) The formal group law (FGL) of the GCT  $E_C^*(\cdot)$  agrees with the FGL associated to the elliptic curve  $C$ .

Multiplicative GCT's satisfying these two properties are called *elliptic cohomology theories*. In the subject of elliptic cohomology, there is a construction due to Landweber which shows how to build a multiplicative generalized cohomology theory  $E_C^*(\cdot)$  associated to a pair  $(R, C)$ . Associated to any GCT is a spectrum defined up to homotopy. The hard work of Hopkins, et al, was to show that the assignment from pairs  $(R, C)$  to spectra is indeed a functor (i.e., relevant diagrams commute on the nose, rather than just up to homotopy) if one only allows isogenies and base-changes as morphisms in the category of pairs  $(R, C)$ .

Over  $\mathbb{C}$ , all  $E_C^*(\cdot)$ 's are direct sums of ordinary cohomology with a funny multiplication defined by the elliptic curve. Over other rings  $R$ , it is more complicated.

Now, property ii) of elliptic cohomology theories requires some explanation. Let  $C$  be a Weierstrass curve over a commutative ring  $R$  and let  $E_C^*(\cdot)$  be the associated generalized cohomology theory. It is a fact that  $E_C^*(\mathbb{C}P^\infty) \simeq E_C^*[[x]]$  where  $x$  is a chosen element in  $E_C^0(\mathbb{C}P^\infty)$ . (Recall that because  $E_C^* = E_C^*(\text{pt})$  is graded, we can choose the generator  $x$  in degree zero.)

Let us say that  $x' \in E_C^0(\mathbb{C}P^\infty)$  is a *generator*<sup>12</sup> if  $E_C^*[[x']] \rightarrow E_C^*(\mathbb{C}P^\infty)$  is an isomorphism. If  $x$  and  $x'$  are generators, then  $x' = \sum_{i=0}^{\infty} a_i x^i \in R[[x]]$  and this

<sup>12</sup>This is ad hoc terminology.

is an invertible expression *with respect to substitution*. In other words, the set of generators is a torsor for  $(R[[x]], \cdot)^\times$ .

Given a generator  $x$ , we get classes  $x_1, x_2 \in E_C^*(\mathbb{C}P^\infty \times \mathbb{C}P^\infty)$  by pulling  $x$  back to each factor. Via the Atiyah-Hirzebruch spectral sequence one obtains the isomorphism  $E_C^*(\mathbb{C}P^\infty \times \mathbb{C}P^\infty) = E_C^*[[x_1, x_2]]$ . Now, there is a multiplication map  $\mu: \mathbb{C}P^\infty \times \mathbb{C}P^\infty \rightarrow \mathbb{C}P^\infty$ , defined up to homotopy, which is commutative, associative, and has a unit, all defined up to homotopy. If one thinks of points in  $\mathbb{C}P^\infty$  as homogeneous polynomials then this corresponds to multiplication of polynomials. Via homotopy theory one can think of the classifying map products of the tensor powers of the Hopf line bundle. In any case, there is an induced map in cohomology

$$\begin{array}{ccc} E_C^*(\mathbb{C}P^\infty \times \mathbb{C}P^\infty) & \longleftarrow & E_C^*(\mathbb{C}P^\infty) \\ \updownarrow & & \updownarrow \\ E_C^*[[x_1, x_2]] & \longleftarrow & E_C^*[[x]] \end{array}$$

where the last map sends  $x$  to  $F(x_1, x_2) = \sum_{i,j} a_{ij} x_1^i x_2^j$  where  $a_{ij} \in R$  since the degrees of  $x$ ,  $x_1$ , and  $x_2$  are all zero. In other words,  $F$  is a formal power series in the variables  $x_1$  and  $x_2$  (which thus depends on the choice of generator  $x$ ).

**Definition 20.1.** A *formal group law* over a ring  $R$  is a formal power series  $F(x, y) \in R[[x, y]]$  such that

- (1)  $F(x, 0) = x = F(0, x)$  (unit property)
- (2)  $F(x, y) = F(y, x)$  (commutativity)
- (3)  $F(F(x, y), z) = F(x, F(y, z))$ . (associativity)

Properties 1,2,3 are satisfied by the power series  $F(x_1, x_2)$  determined by  $E_C^*(\cdot)$ . Thus  $E_C^*(\cdot)$  determines a formal group law over  $R$ .

It turns out that elliptic curves determine a formal group law as well. It is a fact that if  $C$  is a Weierstrass curve over  $R$  then the *smooth* points of  $C$  as a subset of  $\mathbb{P}_R^2$  have the structure of an abelian group. The group law can be given a simple geometric description when the base ring is algebraically closed field  $k$ . Given two points  $P$  and  $Q$  on  $C$  form the projective line  $L$  in  $\mathbb{P}_k^2$  passing through  $P$  and  $Q$ . Any line in the projective plane must meet a cubic curve three times by Bezout's theorem, so the line  $L$  determines a third point  $R$  on the curve  $C$ . Then one forms the line through this point and the marked point at infinity to get a third point on the curve which is defined to be  $P + Q$ . This is depicted Figure 1.

The group determined by the smooth points of an elliptic curve is one of three types depending on the type of singularity the curve has.

- a) Cusp curve: e.g.  $y^2 = x^3$ . The smooth points form the additive group  $\mathbb{G}_a = (R, +)$ .
- b) Nodal curve: e.g.  $y^2 = x^2(x+1)$ . The smooth points form the multiplicative group  $\mathbb{G}_m = (R, \times)$ .
- c) Smooth curve: e.g.  $y^2 = x(x^2 - 1)$ . The smooth points form a group as described geometrically above.

One can express these group laws in terms of a local parameter  $z$  about the marked point (the unit in the group). Expanding as a power series, one obtains a formal group law associated to an elliptic curve. Of course, there are different choices of local parameter, which lead to different power series representing the

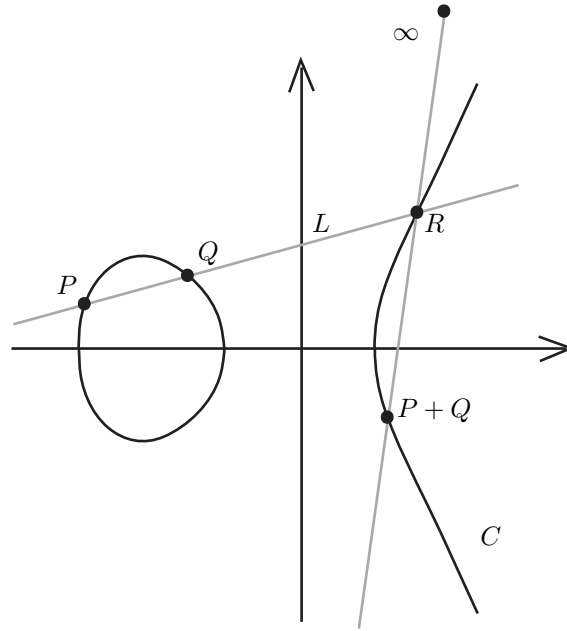

FIGURE 1. The law of addition on a smooth elliptic curve. The figure shows the real points of the curve  $y^2 = x(x^2 - 1)$  in an affine chart for  $\mathbb{C}P^2$  and the lines used to determine the sum  $P + Q$  of the points  $P$  and  $Q$ .

formal group law. However, given two such parameters  $z, z'$  there is a formal relation  $z' = f(z)$  for some  $f \in R[[z]]$ . In kind, the ambiguity in the power series representing the formal group law obtained from  $C$  is the same as the ambiguity in the power series representing the formal group law obtained from  $E_C^*$ .

*Remark 20.2* (Notetaker's comment). One can see the geometry of the groups in the case  $R = \mathbb{C}$  quite nicely. In the smooth case, the curve is a Riemann surface of genus 1. Let's consider the curve which is given in affine coordinates by the equation  $y^2 = x(x - \mu)(x + \lambda)$  where  $\lambda = \mu = 1$ , i.e.,  $y^2 = x(x^2 - 1)$ . We consider  $x \mapsto x(x^2 - 1)$  as a map of the Riemann sphere and we attempt to compute  $y$  in terms of  $x$  by taking the square root  $y = \exp(\frac{1}{2} \log(x(x^2 - 1)))$ . This involves choosing a branch for the logarithm on the range of  $x(x^2 - 1)$ . If we choose to cut along the non-negative real axis in the range, then we must remove the real intervals  $[-1, 0] \cup [1, \infty]$  along the meridians in the Riemann sphere connecting 0 and  $\infty$ . Making these cuts we obtain an annulus. The Riemann surface for  $y$  is obtained by gluing two copies of this annulus to form a torus. The corresponding group is  $\mathbb{C}/\Lambda_\tau$ .

Letting  $\mu \rightarrow 0$  gives a nodal curve and this corresponds to contracting one of the generating cycles in the torus to a point. Topologically, we obtain a sphere with two points identified. Removing this singular point we see the multiplicative group  $\mathbb{C}^* = \mathbb{G}_m(\mathbb{C})$ .

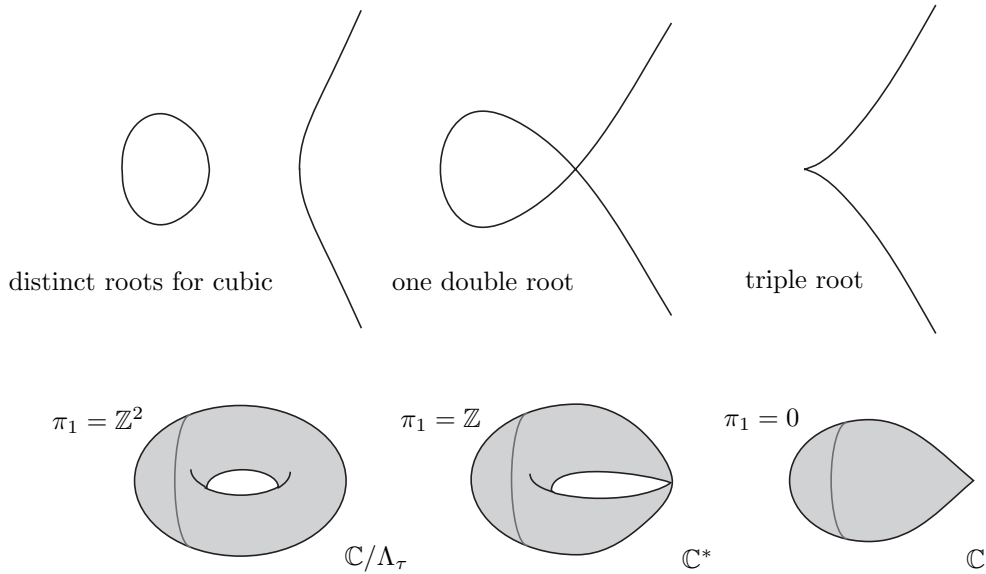

FIGURE 2. Real points of some elliptic curves over  $\mathbb{C}$ ,  $y^2 = f(x)$  where  $f(x)$  is a cubic polynomial. Also shown is the Riemann surface associated to the smooth curve and its corresponding topological degenerations, and the associated groups of smooth points.

Letting  $\lambda \rightarrow 0$  next contracts the remaining generator in homology to a point and gives us the cusp curve. Topologically, we obtain a sphere. But, it is not a smooth sphere, it is the tear-drop orbifold. Removing the lone singular point we see the additive group  $\mathbb{C} = \mathbb{G}_a$ . See Figure 2.

Next time we will go on to the realm of field theories, but let's make one final remark. Brown and Petersen have illustrated the range of generalized cohomology theories. At one end is ordinary cohomology which is the easiest to compute and calculate with. At the other end is the very difficult world of stable cohomotopy. In passing from one extreme to the other, one goes from ordinary cohomology to  $K$ -theory to elliptic cohomology and onward. This has much the same feel as increasing the bordism category dimension in field theories. Note that there as well, the difficulty in construction climbs rapidly with with dimension of the morphisms in the bordism category.

### 21. MONOIDAL CATEGORIES AND 2-CATEGORIES

Let's return to now to field theories. Earlier, we gave a rough definition of field theories of various flavors TFT, CFT, and RFT.

**Definition 21.1.** (Rough) A  $d$ -dimensional Riemannian field theory (a  $d$ -RFT) is a symmetric monoidal functor

$$E: d\text{-RB} \rightarrow \text{TV}$$

where the objects of  $d$ -RB are  $(d - 1)$ -dimensional closed manifolds and the morphisms are Riemannian bordisms modulo isometries inducing the identity on each end.

Today, we will review some terminology from category theory that we will need in order to sharpen this definition. The first important notion is that of a symmetric monoidal category. Familiar examples abound. In the category of topological spaces, the disjoint union provides a monoidal structure and the empty set is the monoidal unit, i.e.,  $(\text{Top}, \amalg, \emptyset)$  is a symmetric monoidal category. Alternatively,  $(\text{Top}, \times, \text{pt})$  is a symmetric monoidal structure on the category  $\text{Top}$ . Similarly the category of vector spaces over a field  $k$  is a symmetric monoidal category with monoidal structure given by the tensor product and scalar field  $k$  as the monoidal unit. If the monoidal structure was given by the direct sum, then the zero vector space would be the monoidal unit.

The formal definition appears somewhat involved, but with the right point of view, can seem quite natural. One needs a functor  $\otimes: \mathcal{C} \times \mathcal{C} \rightarrow \mathcal{C}$  and a unit object  $1 \in \mathcal{C}$  satisfying various properties which are categorical analogs of associativity and identity properties. But in category theory, it is better to demand isomorphism rather than equality in these properties and as such, the isomorphisms become part of the data the definition.

**Definition 21.2.** A *monoidal category* is a triple  $(\mathcal{C}, \otimes, 1)$  where  $\mathcal{C}$  is a category,  $\otimes: \mathcal{C} \times \mathcal{C} \rightarrow \mathcal{C}$  is a functor (*the monoidal product*),  $1$  is an object of  $\mathcal{C}$  (*the monoidal unit*) together with natural isomorphisms  $\alpha_{X,Y,Z}: (X \otimes Y) \otimes Z \simeq X \otimes (Y \otimes Z)$  (called *associators*), and natural isomorphisms  $\rho_X: X \otimes 1 \simeq X$  and  $\lambda_X: 1 \otimes X \rightarrow X$  (*left and right inverses, respectively*) for each  $X, Y, Z \in \mathcal{C}$  satisfying the following coherence conditions.

- i) For each  $W, X, Y, Z \in \mathcal{C}$  the following pentagon diagram commutes. (Note that we have abbreviated the object  $X \otimes Y$  of  $\mathcal{C}$  by  $(XY)$ .)

$$(21.1) \quad \begin{array}{ccc} ((WX)Y) \otimes Z & \xrightarrow{\alpha_{W,X,Y} \otimes \text{id}_Z} & (W(XY)) \otimes Z \xrightarrow{\alpha_{W,(XY),Z}} W \otimes ((XY)Z) \\ \alpha_{(WX),Y,Z} \downarrow & & \downarrow \text{id}_W \otimes \alpha_{X,Y,Z} \\ (WX) \otimes (YZ) & \xrightarrow{\alpha_{W,X,(YZ)}} & W \otimes (X(YZ)) \end{array}$$

- ii) For each  $X, Y \in \mathcal{C}$ , the following diagram commutes.

$$(21.2) \quad \begin{array}{ccc} (X \otimes 1) \otimes Y & \xrightarrow{\alpha_{X,1,Y}} & X \otimes (1 \otimes Y) \\ \rho_X \otimes Y \searrow & & \swarrow X \otimes \lambda_Y \\ & X \otimes Y & \end{array}$$

Thanks to foundational work of Mac Lane, these coherence conditions guarantee that any diagram whose morphisms are built from  $\alpha$ ,  $\lambda$ ,  $\rho$ , identities, and tensor products will commute.

<sup>13</sup>The cartesian product of two categories  $\mathcal{C}$  and  $\mathcal{D}$  has objects which are pairs of objects, one from  $\mathcal{C}$  and one from  $\mathcal{D}$ , and morphisms which are pairs of morphisms.

**Definition 21.3.** Let  $(\mathcal{C}, \otimes, 1)$  be a monoidal category. A *braiding* on  $\mathcal{C}$  is a collection of natural isomorphisms

$$\sigma_{X,Y}: X \otimes Y \rightarrow Y \otimes X$$

one for each  $X, Y \in \mathcal{C}$ , such that the following two diagrams commute for all  $X, Y, Z \in \mathcal{C}$ . (Note, again, that we have abbreviated the object  $X \otimes Y$  of  $\mathcal{C}$  by  $(XY)$ .)

(21.3)

$$\begin{array}{ccc}
 X \otimes (YZ) \xrightarrow{\sigma_{X,(YZ)}} (XY) \otimes Z & & (XY) \otimes Z \xrightarrow{\sigma_{(XY),Z}} Z \otimes (XY) \\
 \alpha_{X,Y,Z} \uparrow & & \alpha_{X,Y,Z} \downarrow \\
 (XY) \otimes Z & & Y \otimes (ZX) \\
 \sigma_{X,Y} \otimes \text{id}_Z \downarrow & & \text{id}_Y \otimes \sigma_{X,Z} \uparrow \\
 (YX) \otimes Z \xrightarrow{\alpha_{Y,X,Z}} Y \otimes (XZ) & & X \otimes (YZ) & & (ZX) \otimes Y \\
 & & \text{id}_X \otimes \sigma_{Y,Z} \downarrow & & \sigma_{X,Z} \otimes \text{id}_Y \uparrow \\
 & & X \otimes (ZY) \xleftarrow{\alpha_{X,Z,Y}} (XZ) \otimes Y & & 
 \end{array}$$

A monoidal category together with a braiding is a *braided category*.

For example, on the category of  $\mathbb{Z}/2\mathbb{Z}$ -graded vector spaces over a field we define a braiding via the isomorphisms  $\sigma_{X,Y}: X \otimes Y \rightarrow Y \otimes X$  determined by the assignments  $x \otimes y \mapsto (-1)^{|x||y|} y \otimes x$  where  $|x| \in \{0, 1\}$  denotes the degree of a homogeneous element  $x$ .

The next notion we need to discuss is that of an internal category which will provide the right language for discussing bordism categories. This is a slightly more sophisticated notion.

**Definition 21.4.** A (small) category (without units) consists of sets  $C_0$  (objects) and  $C_1$  (morphisms) and maps  $s: C_1 \rightarrow C_0$  (source map) and  $t: C_1 \rightarrow C_0$  (target map),  $c: C_1 \times_{C_0} C_1 \rightarrow C_1$  (law of composition)<sup>14</sup> such that the following diagrams commute.

i) (One can specify the source and target of a composition)

$$(21.4) \quad \begin{array}{ccccc}
 C_1 & \xleftarrow{\pi_2} & C_1 \times_{C_0} C_1 & \xrightarrow{\pi_1} & C_1 \\
 \downarrow s & & \downarrow c & & \downarrow t \\
 C_0 & \xleftarrow{s} & C_1 & \xrightarrow{t} & C_0
 \end{array}$$

ii) (Associativity)

$$(21.5) \quad \begin{array}{ccc}
 C_1 \times_{C_0} C_1 \times_{C_0} C_1 & \xrightarrow{c \times \text{id}} & C_1 \times_{C_0} C_1 \\
 \text{id} \times c \downarrow & & \downarrow c \\
 C_1 \times_{C_0} C_1 & \xrightarrow{c} & C_1
 \end{array}$$

To formulate a definition of a category with units in this way involves another pair of diagrams that are easy to write down. Now, one can easily generalize this

<sup>14</sup>The use of the fiber product in the domain ensures that the source of the second map is the target of the first.

framework using the formal properties of these diagrams. Of course, that requires being able to make sense of  $C_1 \times_{C_0} C_1$  in a general category.

Suppose that  $\mathcal{A}$  is a *category with pull-backs*, i.e., for each diagram of the type on the left

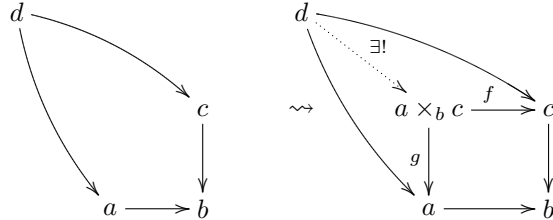

there exists an object which we denote  $a \times_b c$  and morphisms  $f$ , and  $g$  such that there exists a unique morphism  $d \rightarrow a \times_b c$  making the diagram on the right commute.

**Definition 21.5.** A category  $\mathcal{C}$  internal to  $\mathcal{A}$  consists of objects  $C_0, C_1 \in \mathcal{A}$  and morphisms  $s, t: C_1 \rightarrow C_0$  and  $c: C_1 \times_{C_0} C_1 \rightarrow C_1$  such that the diagrams in (21.4) and (21.5) commute.

A category with pull-backs is  $\text{Cat}$ , the category of categories. The objects of this category are categories and the morphisms are functors between categories. (Note: this is certainly not a small category!)

Let us consider the following objects of  $\text{Cat}$ . Let  $C_0$  be the category whose objects are  $(d - 1)$ -dimensional closed manifolds (equipped with a Riemannian bi-collar) which has, as morphisms, diffeomorphisms of  $(d - 1)$ -dimensional manifolds (which extend to an isometry of the bi-collar.) (To be more careful, we will want to think in terms of germs, i.e., identify when equivalent on a sub-collar.) Let  $C_1$  be the category of  $d$ -dimensional Riemannian bordisms extending the bi-collars. The objects of this category are triples, the source and target manifolds with bi-collars, and the bordism itself.

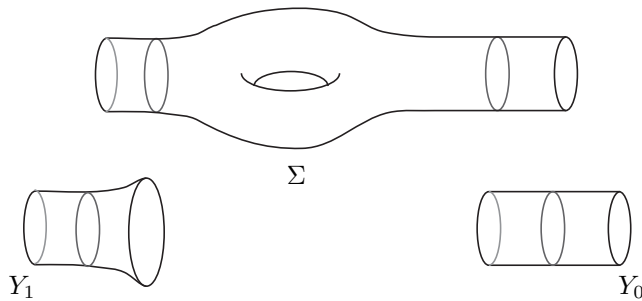

This is a stronger notion of bordism because of extra data of the two bi-collars. This is still not quite good enough, but we will deal with that later.

Now we must ask the question, do  $C_0$  and  $C_1$  form a category internal to  $\text{Cat}$ ? We define the source and target map on the triples making up the objects of  $C_1$  as follows:  $s(Y_1 \xleftarrow{\Sigma} Y_0) = Y_0$  and  $t(Y_1 \xleftarrow{\Sigma} Y_0) = Y_1$ . Composition

$$c: C_1 \times_{C_0} C_1 \rightarrow C_1$$

is defined by gluing along the common part.

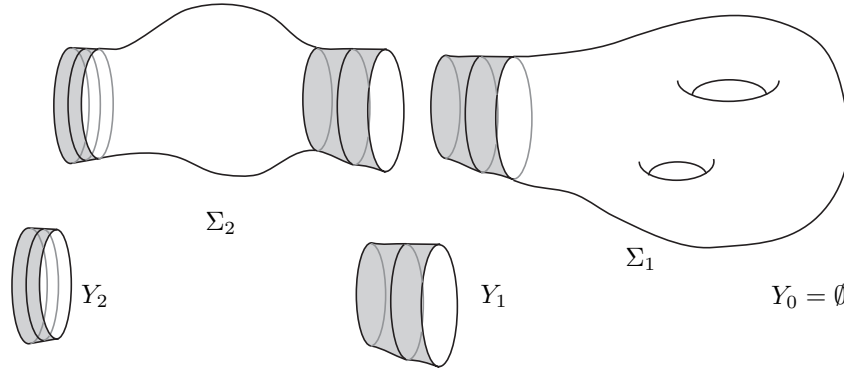

With these definitions, diagram (21.4) commutes on the nose, but diagram (21.5) is only commutative up to a natural isomorphism. This gives rise to a natural transformation  $T$  which is an isomorphism.

$$\begin{array}{ccc}
 C_1 \times_{C_0} C_1 \times_{C_0} C_1 & \xrightarrow{c \times \text{id}} & C_1 \times_{C_0} C_1 \\
 \text{id} \times c \downarrow & \nearrow T & \downarrow \\
 C_1 \times_{C_0} C_1 & \longrightarrow & C_1
 \end{array}$$

Thus, the answer to the question is, unfortunately, no. We need to be able to include the data of this natural transformation. Thus, we need to look at 2-categories.

**Definition 21.6.** A (strict) 2-category  $\mathcal{A}$  consists of

- a) a class of objects  $X, Y, Z, \dots$ ,
- b) for each pair of objects  $X, Y \in \mathcal{A}$ , a *category* of morphisms  $\mathcal{A}(X, Y)$ , and
- c) functors

$$\mathcal{A}(X, Y) \times \mathcal{A}(W, X) \rightarrow \mathcal{A}(W, Y)$$

which are associative (on the nose).

For example,  $\text{Cat}$  can also be regarded as a strict 2-category. The objects are categories and the morphisms between objects are functors. But  $\text{Fun}(\mathcal{C}, \mathcal{D})$  forms a category whose objects are functors and whose morphisms are natural transformations between functors. Moreover, composition of functors is associative on the nose, rather than just up to natural isomorphism.

## 22. INTERNAL CATEGORIES

There is a nice pictorial way of working with 2-categories. Recall that in a 2-category, for each pair of objects, the morphisms between those objects form a category. We will depict objects by capital Roman letters, morphisms between objects by arrows labeled by lower case Roman letters, and morphisms between morphisms by double arrows labeled with Greek letters.

$$X \begin{array}{c} \xrightarrow{f} \\ \Downarrow \alpha \\ \xrightarrow{g} \end{array} Y$$

Here  $\alpha$  is referred to as a 2-morphism.

It is important to note that in a 2-category there are now two types of compositions. First of all, given two objects  $X, Y \in \mathcal{A}$  there is the composition in  $\mathcal{A}(X, Y)$ , which we will call *vertical composition*.

$$X \begin{array}{c} \xrightarrow{\quad} \\ \Downarrow \alpha \\ \xrightarrow{\quad} \\ \Downarrow \beta \\ \xrightarrow{\quad} \end{array} Y$$

The second type of composition is that in the category  $\mathcal{A}$  itself, which we will call *horizontal composition*. This is a functor which acts on objects in the obvious way.

$$Z \xleftarrow{g} Y \quad Y \xleftarrow{f} X \quad \rightsquigarrow \quad Z \xleftarrow{g \circ f} X$$

On morphisms, composition is defined by concatenation.

$$Z \begin{array}{c} \xleftarrow{g'} \\ \Downarrow \beta \\ \xleftarrow{g} \end{array} Y \quad Y \begin{array}{c} \xleftarrow{f'} \\ \Downarrow \alpha \\ \xleftarrow{f} \end{array} X \quad \rightsquigarrow \quad Z \begin{array}{c} \xleftarrow{g' \circ f'} \\ \Downarrow \beta \circ \alpha \\ \xleftarrow{g \circ f} \end{array} X$$

The vertical and horizontal compositions are compatible and the adjective *strict* here means that horizontal composition is associative on the nose. (If it were only associative up to 2-morphism, this would be a bi-category or weak 2-category).

**Definition 22.1.** A *internal category*  $\mathcal{C}$  (without units) in a strict 2-category  $\mathcal{A}$  (which has pull-backs) consists of objects  $C_0, C_1 \in \mathcal{A}$  (the objects and morphisms of  $\mathcal{C}$ ), morphisms  $s, t: C_1 \rightarrow C_0$ ,  $c: C_1 \times_{C_0} C_1 \rightarrow C_1$  (source, target, and composition) and a 2-morphism  $\alpha$  (associator) such that:

i) the diagram

$$\begin{array}{ccccc} C_1 & \xleftarrow{\pi_1} & C_1 \times_{C_0} C_1 & \xrightarrow{\pi_2} & C_1 \\ \downarrow t & & \downarrow c & & \downarrow s \\ C_0 & \xleftarrow{t} & C_1 & \xrightarrow{s} & C_0 \end{array}$$

commutes and where *alpha* is a natural transformation

$$\begin{array}{ccc} C_1 \times_{C_0} C_1 \times_{C_0} C_1 & \xrightarrow{c \times 1} & C_1 \times_{C_0} C_1 \\ \downarrow 1 \times c & \nearrow \alpha & \downarrow c \\ C_1 \times_{C_0} C_1 & \xrightarrow{c} & C_1 \end{array}$$

ii) the pentagon identity holds for associators.

The point is that in the bordism category we can only guarantee that bordisms glued in different orders are diffeomorphic rather than “the same.”

**Definition 22.2.** If  $\mathcal{C}$  and  $\mathcal{D}$  are categories internal to a strict 2-category  $\mathcal{A}$ , then a functor  $f: \mathcal{C} \rightarrow \mathcal{D}$  is a triple  $f = (f_0, f_1, f_2)$  which:

- i) on objects is a morphism  $f: C_0 \rightarrow D_0$  in  $\mathcal{A}$  “functor on objects,”
- ii) on morphisms  $f_1: C_1 \rightarrow D_1$  is a “functor on morphisms” and
- iii) a 2-morphism  $f_2$  in  $\mathcal{A}$

subject to the following requirements. It is compatible with source and target maps, i.e., this diagram

$$\begin{array}{ccccc} C_0 & \xleftarrow{s} & C_1 & \xrightarrow{t} & C_0 \\ f_0 \downarrow & & \downarrow f & & \downarrow f_0 \\ D_0 & \xleftarrow{s} & D_1 & \xrightarrow{t} & D_0 \end{array}$$

commutes. It is compatible with composition,

$$\begin{array}{ccccc} C_1 \times_{C_0} C_1 & \xrightarrow{c} & C_1 & & \\ f_1 \times f_1 \downarrow & \searrow f_2 & \downarrow f_1 & & \\ D_1 \times_{D_0} D_1 & \xrightarrow{c} & D_1 & & \end{array}$$

(plus a diagram expressing compatibility of  $f_2$  with associators in  $\mathcal{C}$  and  $\mathcal{D}$ ).

Finally, we are ready to give a first definition of a  $d$ -RFT. Let  $\text{SymCat}$  denote the strict 2-category of symmetric monoidal categories.

**Definition 22.3.** A  $d$ -dimensional Riemannian field theory is a functor  $d\text{-RB} \rightarrow \text{TV}$  of categories internal to the strict 2-category  $\text{SymCat}$ .

This is still a rough definition because we will need to think in families so we will look internal to a more complicated 2-category involving categories Grothendieck fibered over supermanifolds.

**Definition 22.4.** By  $\text{TV}$  we denote the category of  $\mathbb{Z}/2\mathbb{Z}$ -graded topological vector spaces (locally convex and complete). By  $\text{TV}_0$  we denote the category whose objects are  $\mathbb{Z}/2\mathbb{Z}$ -graded topological vector spaces over  $\mathbb{C}$ , whose morphisms are linear continuous isomorphisms, and which is equipped with the monoidal structure of the graded tensor product with the projective topology. By  $\text{TV}_1$  we denote the category whose objects are continuous linear maps  $T: V \rightarrow W$  and whose morphisms are commutative squares

$$\begin{array}{ccc} V & \xrightarrow{T} & W \\ \downarrow & & \downarrow \\ V' & \xrightarrow{T'} & W' \end{array}$$

whose vertical maps are isomorphisms. The symmetric monoidal structure is given by the tensor product of maps.

$$V \xrightarrow{T} W \quad V' \xrightarrow{T'} W' \quad \rightsquigarrow \quad V \otimes V' \xrightarrow{T \otimes T'} W \otimes W'$$

The source map  $s: \text{TV}_1 \rightarrow \text{TV}_0$  is a symmetric monoidal functor

$$s(V \xrightarrow{T} W) = V.$$

The target map is also a symmetric monoidal functor

$$t(V \xrightarrow{T} W) = W.$$

The composition map is  $c: \text{TV}_1 \times_{\text{TV}_0} \text{TV}_1 \rightarrow \text{TV}_1$  is simply composition of linear maps.

It is important to note that there is an asymmetry present in TV which we will want to reflect in the domain bordism category. This is due to the fact that on the dual of a topological vector space, one has many choices of topology and no natural choice. There is an evaluation map  $\text{ev}: V' \otimes V \rightarrow \mathbb{C}$  but there does not exist a co-evaluation map  $\mathbb{C} \rightarrow V' \otimes V$  for every  $V \in \text{TV}$  unless we restrict our attention to finite dimensional vector spaces. It is imperative that we do not make such a restriction, so we must live with this asymmetry. The domain category  $d\text{-RB}$  should be defined in such a way as to reflect this. “Bordisms need to be read one way in order to allow infinite dimensional vector spaces.”

### 23. $d\text{-RB}$ AS A CATEGORY INTERNAL TO $\text{SymCat}$

Last time we described how to view TV as a category internal to  $\text{SymCat}$ , the strict 2-category of symmetric monoidal categories. By  $\text{TV}_0$  we mean the symmetric monoidal category whose objects are  $\mathbb{Z}/2\mathbb{Z}$ -graded topological vector spaces with the projective tensor product, and whose morphisms are isomorphisms of such spaces. By  $\text{TV}_1$  we mean the symmetric monoidal category of continuous linear maps between objects of  $\text{TV}_0$  together with the tensor product of such maps. As a category internal to the strict 2-category  $\text{SymCat}$ , TV consists of  $\text{TV}_0$ ,  $\text{TV}_1$ , plus source and target functors and the composition functor.

Our rough definition of a Riemannian field theory was that of a functor  $d\text{-RB} \rightarrow \text{TV}$ . We will now make sense of  $d\text{-RB}$  as a category internal to  $\text{SymCat}$ . This, unfortunately, will involve some gory details. So the reader should be warned that pain is ahead.

**Definition of  $d\text{-RB}$ .** By  $d\text{-RB}$  we denote the category internal to  $\text{SymCat}$  defined by the following data.

$d\text{-RB}_0$  is a symmetric monoidal category defined as follows.

- **Objects:** The objects of  $d\text{-RB}_0$  are  $d$ -dimensional Riemannian manifolds  $Y$  (called *bi-collars*) equipped with a decomposition  $Y = Y^- \amalg Y^c \amalg Y^+$  as sets where  $Y^\pm$  are open sub-manifolds of  $Y$ ,  $Y^c$  is a closed  $(d-1)$ -dimensional topological submanifold of  $Y$  (called *the core of  $Y$* ) with  $Y^c \subset \text{closure}(Y^\pm)$ .
- **Morphisms:** Given two objects  $Y_0$  and  $Y_1$ , a morphism of  $d\text{-RB}_0$  from  $Y_0$  to  $Y_1$  is a germ of an isometric embedding  $f: V_0 \rightarrow Y_1$  of an open tubular neighborhood  $V_0$  of  $Y_0^c$  into  $Y_1$  such that  $f(Y_0^c) = Y_1^c$  and  $f(V_0^\pm) \subset Y_1^\pm$  where  $V_0^\pm = V_0 \cap Y_0^\pm$ .
- **Symmetric Monoidal Structure:** Disjoint Union.
- **Monoidal unit:** Empty set.

Here is a picture of an object  $Y = Y_1 \amalg Y_2 \amalg Y_3$  in  $2\text{-RB}_0$ .

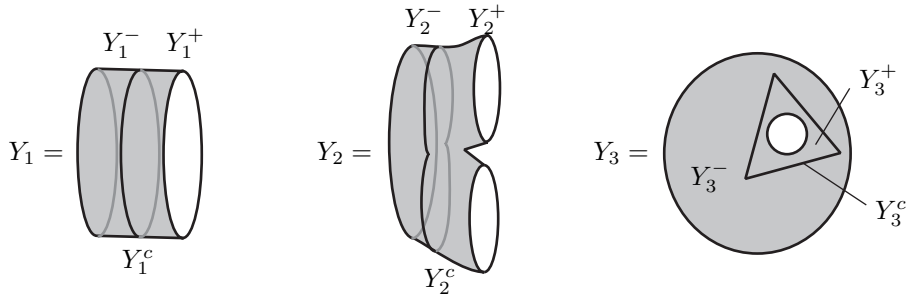

The pictures are meant to suggest the metric structure on each bi-collar by its depicted embedding. Note that the core of  $Y_1$  is a smooth submanifold while the cores of  $Y_2$  and  $Y_3$  are merely topological submanifolds. This is allowed. Also, we do not require the bi-collar to have the topology of  $Y^c \times [0, 1]$  as is evident in the case of  $Y_2$ .

This category has an involution  $Y \mapsto Y^*$ . Given  $Y \in d\text{-RB}_0$ , we define an object  $Y^* \in d\text{-RB}_1$  by switching the labels of the plus and minus parts.

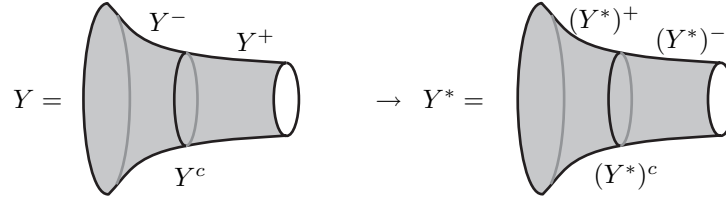

$d\text{-RB}_1$  is a symmetric monoidal category defined as follows.

- Objects: The objects of  $d\text{-RB}_1$  are triples  $(Y_1 \xleftarrow{\Sigma} Y_0)$  (called a *Riemannian bordism from  $Y_0$  to  $Y_1$* ) consisting of the information: a Riemannian manifold  $\Sigma$ , and smooth maps  $i_k: W_k \subset Y_k \rightarrow \Sigma$  from an open neighborhood  $W_k$  of  $Y_k^c$ , for each  $k = 0, 1$ . These data satisfy the conditions:
  - i) the *core of  $\Sigma$* ,  $\Sigma^c := \Sigma \setminus (i_1(W_1^-) \cup i_0(W_0^+))$  is compact,
  - ii)  $i_1: W_1 \subset Y_1 \rightarrow \Sigma$  is an isometric embedding,
  - iii)  $i_0|_{W_0^+}: W_0^+ \rightarrow \Sigma$  is an isometric embedding,
  - iv)  $i_0(W_0^+) \cap i_1(W_1^-) = \emptyset$ .
- Morphisms: isometries of  $\Sigma$  preserving the given data.
- Symmetric Monoidal Structure: Disjoint Union.
- Monoidal unit: Empty set.

Here is a picture of an object  $Y_2 \xleftarrow{\Sigma} Y_1$  describing a bordism between the objects  $Y_1$  and  $Y_2$  in  $d\text{-RB}_1$ .

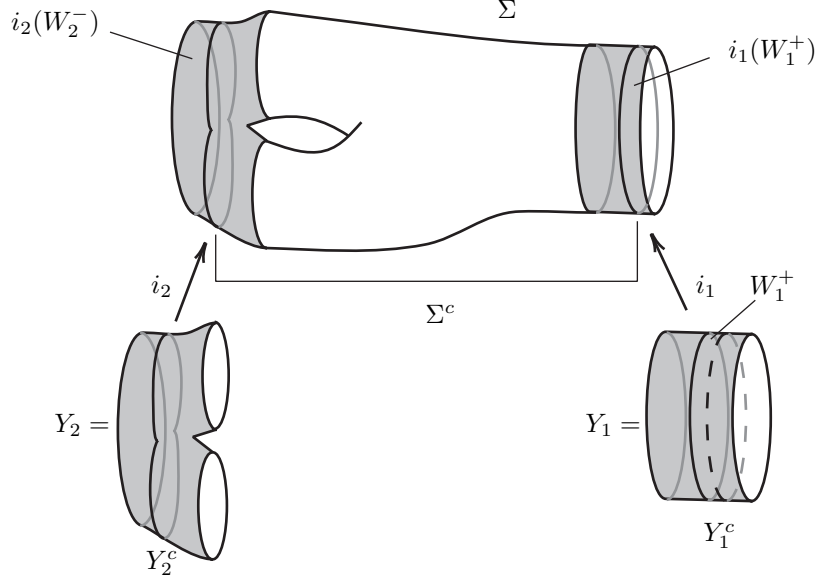

The difference between requirements ii) and iii) in the definition of the objects of  $d\text{-RB}_1$  builds in an intrinsic asymmetry in  $d\text{-RB}$ . This is to reflect the inherent defect in the category of vector spaces in that it does not admit a co-evaluation.

Note that the bordisms could be small enough that the bi-collars overlap. In fact, the infinitely thin bordism gives an identity with respect to the law of composition.

The composition functor

$$d\text{-RB}_1 \times_{d\text{-RB}_0} d\text{-RB}_1 \xrightarrow{c} d\text{-RB}_1$$

is defined in a straightforward manner. To glue two bordisms

$$Y_2 \xleftarrow{\Sigma'} Y_1 \quad Y_1 \xleftarrow{\Sigma} Y_0$$

one forms the bordism  $\Sigma''$  by first restricting so that  $i_1$  and  $i'_1$  have the same domain. Then one forms

$$\Sigma'' := \Sigma' \amalg (\Sigma \setminus i_1(W_1^- \cup Y_1^c)) / \sim$$

where  $i'_1(W_1^+)$  is identified with  $i_1(W_1^+)$ .

*Example 23.1.* Here are two interesting bordisms present in  $d\text{-RB}_1$ .

i) The identity bordism from  $Y$  to itself.

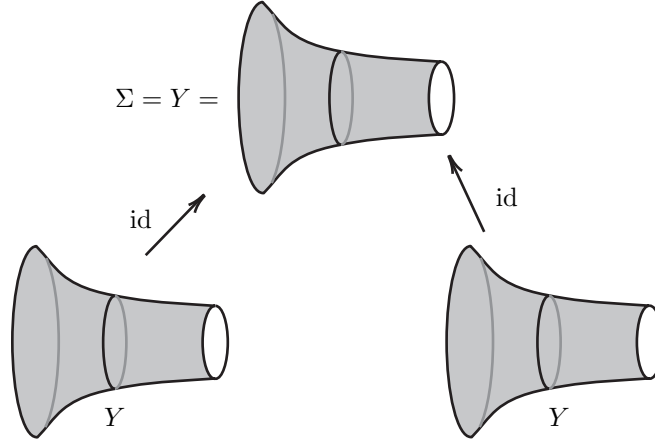

ii) The Evaluation bordism  $\emptyset \xleftarrow{\text{ev}_Y} Y^* \amalg Y$ .

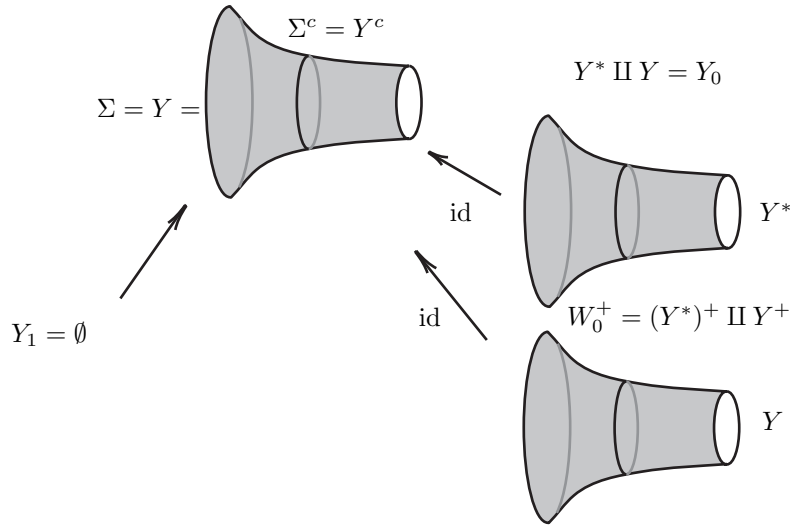

#### 24. THE DEFINITION OF FIELD THEORIES

Last time we carefully defined the symmetric monoidal category  $d\text{-RB}_1$  and saw two examples of interesting elements, the identity bordism  $Y \xleftarrow{\text{id}} Y$  and the evaluation bordism  $\emptyset \xleftarrow{\text{ev}_Y} Y^* \amalg Y$ . Let us now see that there is no co-evaluation  $Y^* \amalg Y \leftarrow \emptyset$ . The map  $i_1$  must be a restriction of  $\text{id}_Y \amalg \text{id}_Y$  to a tubular neighborhood of the core of  $Y_1 = Y^* \amalg Y$ . But such a map cannot possibly be an isometric embedding as required.

In unitary field theories, the evaluation bordism in the bordism category is the origin of the sesquilinear form on the vector spaces in the linear target category. A natural question to ask is: how can we geometrically guarantee that this form is positive definite? Presently, the answer is unknown.

We are now ready to state the final version of the definition of Riemannian field theories. Let  $\text{SymCat}/\text{Man}$  denote the strict 2-category of symmetric monoidal categories Grothendieck fibered over  $\text{Man}$ , the category of smooth manifolds.

**Definition of  $\text{TV}^{fam}$ .** By  $\text{TV}^{fam}$  we denote the category internal to the strict 2-category  $\text{SymCat}/\text{Man}$  defined by the following data. (It is the “family version” of the internal category  $\text{TV}$  considered previously.)

$\text{TV}_0^{fam}$  is the symmetric monoidal category of sheaves of topological vector spaces over smooth manifolds defined as follows.

- Objects: Pairs  $(S, \mathcal{V})$  where  $S$  is a smooth manifold and  $\mathcal{V}$  is a sheaf of objects of  $\text{TV}_0$ .
- Morphisms: Commutative diagrams of sheaf maps

$$\begin{array}{ccc} \mathcal{V} & \xrightarrow{\hat{f}} & \mathcal{V}' \\ \downarrow & & \downarrow \\ S & \xrightarrow{f} & S' \end{array}$$

such that  $\hat{f}$  induces an isomorphism on stalks.

- Symmetric Monoidal Structure: Outer tensor product of sheaves.
- Monoidal Unit: The sheaf  $\mathbb{C} \rightarrow \text{pt}$ .

$\text{TV}_1^{fam}$  is the symmetric monoidal category Grothendieck fibered over  $\text{Man}$  defined as follows.

- Objects: Maps of sheaves of topological vector spaces over the same parameter space.

$$\begin{array}{ccc} \mathcal{V}_0 & \xrightarrow{T} & \mathcal{V}_1 \\ \downarrow & & \downarrow \\ S & \xlongequal{\quad} & S \end{array}$$

- Morphisms: Pairs of cartesian morphisms  $\hat{f}_0$  and  $\hat{f}_1$  making diagrams of the following type commute.

$$\begin{array}{ccccc} \mathcal{V}_0 & \xrightarrow{\hat{f}_0} & \mathcal{V}'_0 & & \\ \downarrow & \searrow & \downarrow & \searrow & \\ & \mathcal{V}_1 & \xrightarrow{\hat{f}_1} & \mathcal{V}'_1 & \\ \downarrow & \swarrow & \downarrow & \swarrow & \\ S & \xrightarrow{f} & S' & & \end{array}$$

- Symmetric Monoidal Structure: Tensor product of sheaf maps.
- Monoidal Unit:

**Definition of  $d\text{-RB}^{fam}$ .** By  $d\text{-RB}^{fam}$  we denote the category internal to the strict 2-category  $\text{SymCat}/\text{Man}$  defined by the following data. (It is the “family version” of the internal category  $d\text{-RB}$  considered previously.)

$d\text{-RB}_0^{fam}$  is the symmetric monoidal category fibered over  $\text{Man}$  defined as follows.

- Objects: Smooth submersions  $Y \rightarrow S$  with  $d$ -dimensional fibers with the following additional data: 1) a decomposition  $Y = Y^+ \amalg Y^c \amalg Y^-$  as sets where  $Y^c$  is a topological submanifold of  $Y$  of codimension 1, called *the core* of  $Y$ ,  $Y^\pm$  are smooth open sub-manifolds with containing  $Y^c$  in their closure.
- Morphisms:
- Symmetric Monoidal Structure:
- Monoidal Unit:

$d\text{-RB}_1^{fam}$  is the symmetric monoidal category defined as follows.

- Objects:
- Morphisms:  $i_0$  and  $i_1$  become maps over the identity on  $S$ .
- Symmetric Monoidal Structure:
- Monoidal Unit:

**Definition 24.1** (Final Version). A  $d$ -dimensional Riemannian field theory is a functor  $E: d\text{-RB}^{fam} \rightarrow \text{TV}^{fam}$  of categories internal to the strict 2-category  $\text{SymCat}/\text{Man}$ .

Here is a picture of an object in  $d\text{-RB}_0^{fam}$ .

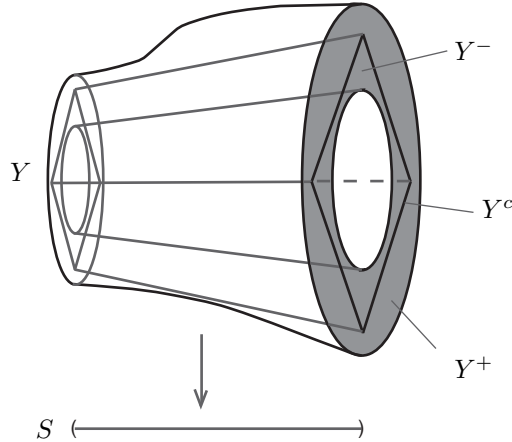

## 25. SUPERMANIFOLDS

Okay, now for a digression on super-manifolds. Recall that a super vector space over a field  $k$  is simply a  $\mathbb{Z}/2\mathbb{Z}$ -graded vector space over  $k$ . The category  $\text{Vect}_k$  of vector spaces over  $k$  and linear maps between them, together with the algebraic tensor product of vector spaces  $\otimes$ , forms a monoidal category  $(\text{Vect}_k, \otimes, k)$ . Analogously, the category of super vector spaces  $\text{SVect}_k$  together with the algebraic tensor product of graded vector spaces forms a monoidal category  $(\text{SVect}_k, \otimes, k)$  where the field  $k$  is viewed as a super vector space of dimension  $1|0$ .

An associative algebra  $C$  with unit over  $k$  is a vector space  $C$  over  $k$  together with a multiplication map  $m: C \otimes C \rightarrow C$  and a distinguished element  $u \in C$  such that various properties hold. For example, the multiplication is associative and  $u$  acts as a unit element for the multiplication, etc. This can be put into a categorical perspective by expressing these properties in terms of commutative diagrams. Recall that if  $(\mathcal{C}, \otimes, 1)$  is a monoidal category, then a monoid in  $\mathcal{C}$  is a

triple  $(C, m, u)$  where  $C \in \mathcal{C}$ ,  $m \in \mathcal{C}(C \otimes C, C)$  and  $u \in \mathcal{C}(1, C)$  satisfying various commutative diagrams expressing associativity, unit properties, etc. An algebra over  $k$  is a monoid in  $(\text{Vect}_k, \otimes, k)$  and analogously, a monoid in  $(\text{SVect}_k, \otimes, k)$  is termed a super algebra over  $k$ .

Typically, we also regard the monoidal category  $(\text{Vect}_k, \otimes, k)$  as a braided category where, given  $V, W \in \text{Vect}_k$ , the braiding isomorphism  $\sigma_{V,W}: V \otimes W \rightarrow W \otimes V$  is the linear map defined by the assignments  $v \otimes w \rightarrow w \otimes v$  for each  $v \in V$ ,  $w \in W$ . Commutativity of the multiplication map for an algebra over  $k$  can then be expressed in terms of commutative diagrams involving the braiding isomorphism and this can be generalized to the definition of a commutative monoid in a braided category. In the monoidal category  $(\text{SVect}_k, \otimes, k)$ , the interesting braiding is the one which encodes the sign rule and is the linear map  $\sigma_{V,W}: V \otimes W \rightarrow W \otimes V$  defined on homogeneous elements by the assignments  $v \otimes w \mapsto (-1)^{|v||w|} w \otimes v$  where  $|v|, |w| \in \{0, 1\}$  denotes the degree. A commutative super algebra over  $k$  is a commutative monoid in the symmetric monoidal category  $(\text{SVect}_k, \otimes, 1, \sigma)$ .

*Example 25.1.* Examples of commutative super algebras abound in geometry and topology.

- a) The first standard example from algebra is the exterior algebra  $\Lambda[\theta_1, \dots, \theta_k]$  where the parity of each of the generators  $\theta_j$  is odd.
- b) If  $M$  is a smooth manifold, then  $C^\infty(M)$  is a commutative super algebra which happens to be purely even.
- c) More generally, the differential forms on  $M$ ,  $\Omega^\bullet(M) = \Omega^{\text{ev}}(M) \oplus \Omega^{\text{odd}}(M)$ , form a commutative super-algebra with respect to the wedge product.
- d) The cohomology of  $M$ ,  $H^\bullet(M, \mathbb{R})$  together with the cup-product gives another example.

**Definition 25.2.** A (complex) super manifold  $M$  of dimension  $d|\delta$  is a pair  $M = (M_{\text{red}}, \mathcal{O}_M)$  where

- $M_{\text{red}}$  is a topological space (called the reduced manifold) and
- $\mathcal{O}_M$  is a sheaf of commutative (complex) super algebras over  $M_{\text{red}}$

such that  $M = (M_{\text{red}}, \mathcal{O}_M)$  is locally isomorphic to

$$\mathbb{R}^{d|\delta} = (\mathbb{R}^{d|\delta}, C^\infty(\mathbb{R}^d, \mathbb{C}) \otimes \Lambda[\theta_1, \dots, \theta_\delta]).$$

A couple of remarks are in order here. First, the topological space  $M_{\text{red}}$  is called the reduced *manifold* because it is a consequence of the definition that  $M_{\text{red}}$  inherits the structure of a smooth manifold. Second, super manifolds come in two flavors: real and complex. A real super manifold has a structure sheaf of commutative super algebras over  $\mathbb{R}$ , whereas in the version we will deal with here the base field is  $\mathbb{C}$ . This distinction is something special to super manifolds. For an ordinary manifold, the structure sheaf may be taken to consist of the smooth real valued functions or the smooth complex valued functions on  $M$ . There is no information gained or lost. The reader should be warned however, that complex super manifolds do not *a priori* have a complex structure on the reduced manifold  $M_{\text{red}}$ . Finally, it should be noted that an ordinary manifold of dimension  $d$  may be regarded as a super manifold of dimension  $d|0$ .

*Example 25.3.* If  $E \rightarrow N$  is a complex vector bundle of rank  $\delta$  over  $N$ , where  $N$  is a smooth manifold of dimension  $d$ , then it can be used to produce a  $d|\delta$ -dimensional

super manifold  $\Pi E$ . One sets  $(\Pi E)_{red} = N$  and defines  $\mathcal{O}_{\Pi E}$  to be the sheaf of smooth sections of the bundle of super commutative algebras  $\bigwedge^\bullet E^*$  over  $N$ .

**Definition 25.4.** Given a super manifold  $M$  the vector space (over  $\mathbb{C}$ ) of smooth functions on  $M$  is defined to be  $C^\infty(M) := \Gamma(\mathcal{O}_M)$ .

For example, if  $N$  is a smooth manifold and  $T_{\mathbb{C}}N$  denotes the complexified tangent bundle of  $N$ , then  $C^\infty(\Pi T_{\mathbb{C}}N) = \Gamma(N, \bigwedge^\bullet(T_{\mathbb{C}}N)) = \Omega^\bullet(N, \mathbb{C})$ .

**Definition 25.5.** Given two super manifolds  $M$  and  $M'$ , a morphism of super manifolds  $M \rightarrow M'$  is a smooth map  $f: M_{red} \rightarrow M'_{red}$  together with a map of sheaves  $\hat{f}: \mathcal{O}_M \rightarrow \mathcal{O}_{M'}$  over  $f$ .

**Definition 25.6.** Let  $\text{SMan}$  denote the category whose objects are super-manifolds and whose morphisms are morphisms are super-manifolds.

It should be noted that a morphism of super manifolds  $M \rightarrow M'$  induces an homomorphism of commutative super algebras  $C^\infty(M) \leftarrow C^\infty(M')$ . Let  $\text{SAlg}$  denote the category of super algebras over  $\mathbb{C}$  and super algebra homomorphisms. The nice thing is that the sheaves involved in the theory are flasque (flabby) sheaves which means roughly that they have many global sections. It turns out that  $\text{SMan}(M, M')$  is in bijection as a set with  $\text{SAlg}(C^\infty(M'), C^\infty(M))$ .

The construction used to produce examples of super manifolds from vector bundles actually gives rise to a functor  $\Pi$  from the category  $\text{Vect}_{\mathbb{C}}\text{Bun}$  of complex vector bundles over smooth manifolds to  $\text{SMan}$ . Both the domain and range categories of this functor are Grothendieck fibered over  $\text{Man}$  and this functor commutes the forgetful functors to  $\text{Man}$ .

**Theorem 25.7** (Batchelor). *The functor  $\Pi: \text{Vect}_{\mathbb{C}}\text{Bun} \rightarrow \text{SMan}$  induces a bijection on isomorphism classes of objects.*

In other words, every super manifold, up to isomorphism, comes from vector bundle via the functor  $\Pi$ . If the functor induced a bijection on morphisms, then it would necessarily be an equivalence of categories. However,  $\Pi$  is injective but not surjective on morphisms in general.

*Example 25.8.* Let us examine the morphisms  $\mathbb{R}^{0|2} \rightarrow \mathbb{R}$ . Regard  $\mathbb{R}^{0|2}$  as  $\Pi E$  where  $E$  is the trivial vector bundle  $\text{pt} \times \mathbb{C}^2 \rightarrow \text{pt}$  and regard  $\mathbb{R}$  as  $\Pi E'$  where  $E'$  is the rank zero vector bundle  $\mathbb{R} \times \{0\} \rightarrow \mathbb{R}$ . Then  $\text{Vect}_{\mathbb{C}}\text{Bun}(E, E')$  is in bijection with  $\mathbb{R}$ . In addition,  $\text{SMan}(\mathbb{R}^{0|2}, \mathbb{R}) = \text{SAlg}(C^\infty(\mathbb{R}), C^\infty(\mathbb{R}^{0|2})) = \text{SAlg}(C^\infty(\mathbb{R}), \Lambda[\theta_1, \theta_2])$ . Since each  $f \in C^\infty(\mathbb{R})$  is purely even, and homomorphisms  $\psi$  of super algebras must preserve degree,  $\psi(f) = \psi_0(f)1 + \psi_1(f)\theta_1\theta_2$  where  $\psi_0, \psi_1: C^\infty(\mathbb{R}, \mathbb{C}) \rightarrow \mathbb{C}$ . What properties must the functions  $\psi_0$  and  $\psi_1$  have for  $\psi$  to be a morphism of super algebras?

On the one hand

$$\begin{aligned} \psi(f)\psi(g) &= (\psi_0(f)1 + \psi_1(f)\theta_1\theta_2)(\psi_0(g)1 + \psi_1(g)\theta_1\theta_2) \\ &= \psi_0(f)\psi_0(g)1 + (\psi_0(f)\psi_1(g) + \psi_1(f)\psi_0(g))\theta_1\theta_2 \end{aligned}$$

and on the other,  $\psi(f)\psi(g) = \psi(fg) = \psi_0(fg)1 + \psi_1(fg)\theta_1\theta_2$ . Matching coefficients, we see that  $\psi_0$  is an algebra homomorphism  $C^\infty(\mathbb{R}, \mathbb{C}) \rightarrow \mathbb{C}$ . Such maps are simply evaluations at points of  $\mathbb{R}$ . Consequently,  $\psi_1$  is a derivation at the point determined by  $\psi_0$ . Thus,  $\text{SMan}(\mathbb{R}^{0|2}, \mathbb{R})$  is in bijection with the set  $T_{\mathbb{C}}\mathbb{R}$ .

Now we would like to make sense of Euclidean super manifolds. In the context of Riemannian geometry, a Euclidean structure on  $M$  is the same as a flat Riemannian metric and this is equivalent to the condition that  $M$  admits an atlas of charts whose transition maps belong to the Euclidean group  $\mathbb{R}^d \rtimes O(d)$ . In keeping with Klein's Erlangen Program, we can define a  $G$ -structure on a manifold  $M$  by demanding that  $M$  admit an atlas whose transition functions belong to an affine group  $G$ . As a super Euclidean group we will use the super Lie group  $\mathbb{R}^{d|\delta} \rtimes \text{Spin}(d)$ .

**Definition 25.9.** Given  $M, N \in \text{SMan}$ , the cartesian product is defined as

$$M \times N = (M_{red} \times N_{red}, p_1^* \mathcal{O}_M \otimes p_2^* \mathcal{O}_N)$$

where  $\mathcal{O}_M$  and  $\mathcal{O}_N$  are viewed as sheaves of topological algebras with the Frechét topology and the tensor product is that induced on sheaves from the projective tensor product of topological algebras.

The Frechét topology on smooth functions is the only topology for which the multiplication is continuous, so we make use of topological algebras. It is a theorem that in the purely even case, the sheaf  $p_1^* \mathcal{O}_M \otimes p_2^* \mathcal{O}_N$  is isomorphic to  $C^\infty(M \times N)$  as sheaves of topological algebras.

**Definition 25.10.** A *super Lie group* is a group object in the category  $\text{SMan}$ .

So, how do we view  $\mathbb{R}^{1|1}$  as a super Lie group? Here is the physics formula for the group law:

$$((t_1, \theta_1), (t_2, \theta_2)) \mapsto (t_1 + t_2 + \theta_1 \theta_2, \theta_1 \theta_2)$$

There are at least two ways to interpret this formal expression. The first we can mention now, the second we will do next time. This morphism of super manifolds is equivalent to a morphism of super algebras

$$C^\infty(\mathbb{R}^{1|1}) \otimes C^\infty(\mathbb{R}^{1|1}) \longleftarrow C^\infty(\mathbb{R}^{1|1})$$

or, equivalently, a morphism of super algebras

$$C^\infty(\mathbb{R})[\theta] \otimes C^\infty(\mathbb{R})[\theta] \longleftarrow C^\infty(\mathbb{R})[\theta].$$

According to the formula, this map should be determined by the assignments  $t \mapsto t \otimes 1 + 1 \otimes t + \theta \otimes \theta$  and  $\theta \mapsto \theta \otimes 1 + 1 \otimes \theta$ .

## 26. GENERALIZED SUPERMANIFOLDS AND THE SUPER EUCLIDEAN GROUP

Last time we wrote down the physics formula for the group law  $\mu: \mathbb{R}^{1|1} \times \mathbb{R}^{1|1} \rightarrow \mathbb{R}^{1|1}$ , namely

$$((t_1, \theta_1), (t_2, \theta_2)) \mapsto (t_1 + t_2 + \theta_1 \theta_2, \theta_1 + \theta_2),$$

and discussed one interpretation in terms of induced maps of algebras. Another interpretation involves the functor of points formalism.

Given  $M \in \text{Man}$ , how can one recover  $M$  as a set? The set of morphisms  $\text{Man}(\text{pt}, M)$  is a set bijective to  $M$ . Now, if  $M \in \text{SMan}(\text{pt}, M)$ ,

$$\text{SMan}(\text{pt}, M) = \text{SAlg}(C^\infty(M), C^\infty(\text{pt})) = \text{SAlg}(C^\infty(M)/J, \mathbb{C})$$

where  $J$  is the ideal in  $C^\infty(M)$  generated by the odd elements. A fact from the theory of super manifolds that one should know is that  $C^\infty(M)/J \simeq C^\infty(M_{red})$ . Thus,

$$\text{SMan}(\text{pt}, M) = \text{SAlg}(C^\infty(M_{red}), \mathbb{C})$$

which is bijective to  $M_{red}$  as a set. The moral is that it is not enough to look at just the points of  $M$ .

**Definition 26.1.** Given  $S, M \in \text{SMan}$ , define

$$M_S := \text{SMan}(S, M)$$

and call it *the set of  $S$ -points* of  $M$ .

From this we obtain a functor  $Y_M \in \text{Fun}(\text{SMan}^{op}, \text{Set})$  by  $S \mapsto M_S$  and then a functor  $\text{SMan} \rightarrow \text{Fun}(\text{SMan}^{op}, \text{Set})$  by the assignment  $M \rightarrow Y_M$ . Of course, this could have been done in any category  $\mathcal{C}$ .

**Lemma 26.2** (Yoneda). *Let  $\mathcal{C}$  be a category. The functor  $Y: \mathcal{C} \rightarrow \text{Fun}(\mathcal{C}^{op}, \text{Set})$  is full and faithful, i.e., on morphisms  $Y: \mathcal{C}(M, N) \rightarrow \text{NatTrans}(Y_M, Y_N)$  is surjective (full) and injective (faithful).*

The upshot is that  $\text{Fun}(\mathcal{C}^{op}, \text{Set})$  is a larger category that ‘‘contains’’  $\mathcal{C}$  as a subcategory.

**Definition 26.3.** A *generalized super manifold* is an object of  $\text{Fun}(\text{SMan}^{op}, \text{Set})$ .

Now, let’s apply the Yoneda lemma to construct the map  $\mu$ . First, we must understand the  $S$ -points of  $\mathbb{R}^{d|\delta}$ ,

$$\mathbb{R}_S^{d|\delta} := \text{SMan}(S, \mathbb{R}^{d|\delta}) = \text{SAlg}(C^\infty(\mathbb{R}^{d|\delta}), C^\infty(S)).$$

By definition  $C^\infty(\mathbb{R}^{d|\delta}) = C^\infty(\mathbb{R}^d) \otimes \Lambda[\theta_1, \dots, \theta_\delta]$ . Topologically,  $C^\infty(\mathbb{R}^d)$  is generated by the coordinate functions  $t_1, \dots, t_d$ . Thus,  $\psi \in \text{SAlg}(C^\infty(\mathbb{R}^{d|\delta}), C^\infty(S))$  is determined by what it does to  $t_1, \dots, t_d$  and  $\theta_1, \dots, \theta_\delta$ . Since  $\psi$  must also preserve parity, we have a bijection of sets,

$$\text{SAlg}(C^\infty(\mathbb{R}^{d|\delta}), C^\infty(S))$$

with

$$\underbrace{C^\infty(S)^{ev} \oplus \dots \oplus C^\infty(S)^{ev}}_{d \text{ copies}} \oplus \underbrace{C^\infty(S)^{odd} \oplus \dots \oplus C^\infty(S)^{odd}}_{\delta \text{ copies}}$$

given by the assignment

$$\psi \mapsto (\psi(t_1), \dots, \psi(t_d), \psi(\theta_1), \dots, \psi(\theta_\delta)).$$

Now, in order to interpret the physics formula for the group law on  $\mathbb{R}^{1|1}$ , we apply the functor of points formalism to describe not one morphism

$$\mu: \mathbb{R}^{1|1} \times \mathbb{R}^{1|1} \rightarrow \mathbb{R}^{1|1}$$

but a whole collection of maps between sets

$$\mu_S: (\mathbb{R}^{1|1} \times \mathbb{R}^{1|1})_S \rightarrow \mathbb{R}_S^{1|1}$$

which is natural in  $S \in \text{SMan}$ . Now  $(\mathbb{R}^{1|1} \times \mathbb{R}^{1|1})_S = \mathbb{R}_S^{1|1} \times \mathbb{R}_S^{1|1}$ , so to specify  $\mu_S$  we just write down the map

$$((t_1, \theta_1), (t_2, \theta_2)) \mapsto (t_1 + t_2 + \theta_1\theta_2, \theta_1 + \theta_2)$$

where now  $t_1, t_2 \in C^\infty(S)^{ev}$  and  $\theta_1, \theta_2 \in C^\infty(S)^{odd}$ .

The next notion which needs to be discussed is that of *internal hom*. This is, more or less, a way of starting with a set of morphisms and viewing it as an object. For example, given  $X, Y \in \text{Top}$ , the set  $\text{Top}(X, Y)$  can be given the compact open topology and then viewed as a topological space, i.e., as an object of  $\text{Top}$ . For

smooth manifolds this doesn't quite work because the mapping space is no longer a finite dimensional manifold unless either the source or target object is a point.

**Definition 26.4.** Given  $M, N \in \text{SMan}$ , we denote by  $\underline{\text{SMan}}(M, N)$  the generalized super manifold (“internal hom”) defined via the functor of points by  $\underline{\text{SMan}}(M, N)_S := \text{SMan}(M \times S, N)$ .

This gives a nice way of thinking about mapping spaces as generalized manifolds.

**Proposition 26.5.** *If  $M \in \text{Man}$ , then  $\underline{\text{SMan}}(\mathbb{R}^{0|1}, M)$  is isomorphic to  $\Pi T_{\mathbb{C}}M$ .*

*Proof.* We need to find a natural collection of bijections

$$\underline{\text{SMan}}(\mathbb{R}^{0|1}, M)_S \longleftrightarrow (\Pi T_{\mathbb{C}}M)_S.$$

Unraveling,

$$\begin{aligned} \underline{\text{SMan}}(\mathbb{R}^{0|1}, M)_S &= \text{SMan}(\mathbb{R}^{0|1} \times S, M) \\ &= \text{SAlg}(C^\infty(M), C^\infty(S \times \mathbb{R}^{0|1})) \\ &= \text{SAlg}(C^\infty(M), C^\infty(S)[\theta]), \end{aligned}$$

whereas

$$\begin{aligned} (\Pi T_{\mathbb{C}}M)_S &= \text{SMan}(S, \Pi T_{\mathbb{C}}M) \\ &= \text{SAlg}(C^\infty(\Pi T_{\mathbb{C}}M), C^\infty(S)) \\ &= \Omega^\bullet(M, \mathbb{C}). \end{aligned}$$

Suppose  $\psi \in \text{SAlg}(C^\infty(M), C^\infty(S)[\theta])$ . Given  $f \in C^\infty(M)$ ,  $\psi(f) = \psi_0(f) + \psi_1(f)\theta$  where  $\psi_0(f) \in C^\infty(S)^{ev}$  and  $\psi_1(f) \in C^\infty(S)^{odd}$ . Now,  $\Omega^\bullet(M, \mathbb{C})$  is generated by functions and 1-forms as an algebra and without loss of generality we can consider one forms of the form  $dg$  for some  $g \in C^\infty(M)$ . So we define  $\tilde{\psi} \in \text{SAlg}(\Omega^\bullet(M, \mathbb{C}), C^\infty(S))$  linearly by the assignments  $f \mapsto \psi_0(f)$  and  $dg \mapsto \psi_1(g)$  using  $\psi$ . We leave it as an exercise to check that  $\tilde{\psi}$  is actually an algebra homomorphism. This assignment is bijective and natural in  $S$ .  $\square$

**The super Euclidean group of  $\mathbb{R}^{d|\delta}$ .** The data we will need to define the super Euclidean group is the following.

- $\mathbb{R}^d$  equipped with the standard inner product, for which we will write  $V$ .
- A choice  $\Delta$  of a module over  $\text{Cl}^{ev}(V) \otimes_{\mathbb{R}} \mathbb{C}$ .
- A  $\text{Spin}(d)$ -equivariant linear map  $\Gamma: \Delta \otimes \Delta \rightarrow V$ .

These data determine a group structure on the super manifold  $V \times \Pi\Delta := \Pi(V \times \Delta)$  where  $V \times \Delta$  is regarded as the trivial bundle over  $V$ .

Using the  $S$ -point formalism, the group law  $(V \times \Pi\Delta)_S \times (V \times \Pi\Delta)_S \rightarrow (V \times \Pi\Delta)_S$  is given by the map

$$((v_1, \theta_1), (v_2, \theta_2)) \mapsto (v_1 + v_2 + \Gamma(\theta_1 \otimes \theta_2), \theta_1 + \theta_2)$$

where  $v_1, v_2 \in C^\infty(S)^{ev} \otimes V$  and  $\theta_1, \theta_2 \in C^\infty(S)^{odd} \otimes \Delta$ .

This makes  $V \times \Pi\Delta$  into a super Lie group. If  $\delta = \dim_{\mathbb{C}} \Delta$ , then  $V \times \Pi\Delta = \mathbb{R}^{d|\delta}$  as a (complex) super manifold. In analogy with the ordinary setting of  $\mathbb{R}^n$ , we say that the action  $\mathbb{R}^{d|\delta}$  on itself is by translations.

**Definition 26.6.** By  $\text{Eucl}(\mathbb{R}^{d|\delta})$  we denote the super Lie group  $\mathbb{R}^{d|\delta} \rtimes \text{Spin}(d)$  where  $\text{Spin}(d)$  acts on  $\mathbb{R}^{d|\delta} = V \times \Pi\Delta$  via  $\text{SO}(d)$  on  $V$  and via  $\text{Cl}^{ev}(V)$  through the module structure on  $\Delta$ .

Some comments are in order with this definition. First of all, the formula for the semi-direct product looks the same as for ordinary groups via the  $S$ -point formalism and so the semi-direct product is well-defined in this setting as well. Secondly, the notation hides a great deal of information. It should be noted that although  $\mathbb{R}^{d|\delta}$  makes sense as a super manifold for any pair of non-negative integers  $d|\delta$ , the group  $\text{Eucl}(\mathbb{R}^{d|\delta})$  only makes sense for certain pairs. While any  $d$  is allowed, the number  $\delta$  is constrained by the representation theory of  $\text{Cl}^{ev}(V) \otimes_{\mathbb{R}} \mathbb{C}$ . Furthermore, the map  $\Gamma$  is suppressed. We are interested in the cases  $0|1$ ,  $1|1$ , and  $2|1$ . In the first two cases, there is a unique  $\Delta$  and in the last case there are two, up to isomorphism. There are also a few choices for  $\Gamma$ . In general, there are several possible modules  $\Delta$  and many possible maps  $\Gamma$  that can be used, particularly if  $\Delta$  is highly reducible.

## 27. SUPER EUCLIDEAN MANIFOLDS

Last time we defined  $\text{Eucl}(\mathbb{R}^{d|\delta}) = \mathbb{R}^{d|\delta} \rtimes \text{Spin}(d)$  as a super Lie group. Recall that the data needed for its definition were: 1) a  $d$ -dimensional inner product space  $V = \mathbb{R}^d$ , a  $\delta$ -dimensional  $\text{Cl}^{ev} \otimes \mathbb{C}$ -module  $\Delta$ , and a  $\text{Spin}(d)$ -equivariant linear map  $\Gamma: \Delta \otimes \Delta \rightarrow V \otimes_{\mathbb{R}} \mathbb{C}$ .

*Example 27.1.* Let  $d|\delta = 2|1$ . Consider the standard Euclidean inner product on  $\mathbb{R}^2$ . Then  $\text{Cl}(\mathbb{R}^2) = \mathbb{H}$  and  $\text{Cl}^{ev}(\mathbb{R}^2) \simeq \mathbb{C}$ . There are two possible choices for  $\Delta$ :

- (1)  $\Delta = \mathbb{C}$  where  $z \in \text{Cl}^{ev}(\mathbb{R}^2) = \mathbb{C}$  acts by multiplication by  $z$ , and
- (2)  $\Delta = \mathbb{C}$  where  $z$  acts by multiplication by  $\bar{z}$ .

By construction  $G = \text{Eucl}(\mathbb{R}^{d|\delta})$  acts on  $\mathbb{M} = \mathbb{R}^{d|\delta}$  (the ‘‘model space’’). In keeping with Klein’s Erlangen Program, we can define a geometry on  $Y$  using the data of  $\mathbb{M}$  and  $G$ . First, note that by an *open set* of a super manifold  $Y$  we mean an open set of the reduced space  $Y_{red}$  together with sheaf obtained from  $\mathcal{O}_Y$  by restriction. If  $Y^{d|\delta}$  is a super-manifold, then a *chart* on  $Y$  is an isomorphism of super-manifolds  $\varphi: U \rightarrow V$  where  $U \subset Y$  is an open subset of  $Y$  and  $V$  is an open subset of  $\mathbb{R}^{d|\delta}$ .

**Definition 27.2.** An  $(\mathbb{M}, G)$ -structure on  $Y^{d|\delta} \in \text{SMan}$  is a maximal atlas charts  $\varphi_i: U_i \rightarrow V_i$  such that for each transition map  $\varphi_j \circ \varphi_i^{-1}: V_i \cap V_j \rightarrow V_i \cap V_j$  there is a  $g_i \in G$  such that  $\varphi_j \circ \varphi_i^{-1}$  is the restriction of the action of  $g_i$  on  $\mathbb{M}$ . A  $(\mathbb{R}^{d|\delta}, \text{Eucl}(\mathbb{R}^{d|\delta}))$ -structure on  $Y$  is called a *Euclidean structure* on  $Y$ .

Note that a Euclidean structure on  $Y$  induces a Euclidean structure plus a spin structure on  $Y_{red}$ . This is because on  $Y_{red}$ , the group  $\mathbb{R}^d \rtimes \text{Spin}(d)$  acts as opposed to just  $\mathbb{R}^d \rtimes \text{SO}(d)$ .

Of course, we need to work in families, so the next definition promotes the previous one to that level.

**Definition 27.3.** A *family of  $(\mathbb{M}, G)$ -manifolds* is a morphism  $\rho \in \text{SMan}(Y, S)$  together with a maximal atlas of charts  $Y \supset U_i \xrightarrow{\varphi} V_i \subset \mathbb{M} \times S$  such that each transition map

$$S \times \mathbb{M} \supset V_i \cap V_j \rightarrow V_i \cap V_j \subset S \times \mathbb{M}$$

is a morphism of  $\text{SMan}$  of the form  $(s, m) \mapsto (s, g(s).m)$  where  $g: \rho(U_i \cap U_j) \rightarrow G$ .

A consequence of this definition is that  $\rho$  always has local sections and in the even case is a submersion.

**Definition 27.4.** A  $d|\delta$ -dimensional EFT over a smooth manifold  $X$  is a functor  $E: d|\delta\text{-EB}^{fam}(X) \rightarrow \text{TV}^{fam}$  between categories internal to the strict 2-category  $\text{SymCat}/\text{SMan}$  of symmetric monoidal categories fibered over  $\text{SMan}$ . The internal categories  $d|\delta\text{-EB}^{fam}$  and  $\text{TV}^{fam}$  are defined as follows.

$\text{TV}_0^{fam}$ : symmetric monoidal category fibered over  $\text{SMan}$ .

- Objects: pairs  $(S, \mathcal{V})$  where  $S \in \text{SMan}$  and  $\mathcal{V}$  is a sheaf of topological  $\mathcal{O}_S$ -modules over  $S_{red}$ .
- Morphisms: Morphisms of ringed spaces inducing isomorphisms on the stalks.
- Monoidal structure:  $(S_1, \mathcal{V}_1) \otimes (S_2, \mathcal{V}_2) := (S_1 \times S_2, \mathcal{V}_1 \boxtimes \mathcal{V}_2)$  where  $\boxtimes$  denotes the external tensor product of sheaves.
- Monoidal unit: The bosonic point.

$\text{TV}_1^{fam}$ : symmetric monoidal category fibered over  $\text{SMan}$ .

- Objects: Morphisms  $T: \mathcal{V}_1 \rightarrow \mathcal{V}_2$  of sheaves of  $\mathcal{O}_S$ -modules over  $S$ .
- Morphisms:
- Monoidal structure:
- Monoidal unit:

$d|\delta\text{-EB}_0^{fam}$ : symmetric monoidal category fibered over  $\text{SMan}$ .

- Objects: Pairs  $(Y \rightarrow S, f)$ , each referred to as a family of Euclidean  $d|\delta$ -manifolds equipped with a map to  $X$  satisfying a number of conditions. The  $(d|\delta + \text{sdim}(S))$ -dimensional supermanifold  $Y$  comes with a (piecewise) sub  $(d-1)|\delta$ -supermanifold of  $Y^c$ , called the *core* of  $Y$  such that the composition  $Y^c \hookrightarrow Y \rightarrow S$  is a proper map (on reduced spaces), and a decomposition  $Y_{red} = Y_{red}^- \amalg Y_{red}^c \amalg Y_{red}^+$  where  $Y_{red}^c$  has codimension 1 in  $Y_{red}$ . The fibers of  $Y \rightarrow S$  are Euclidean supermanifolds.
- Morphisms:
- Monoidal structure:
- Monoidal unit:

$d|\delta\text{-EB}_1^{fam}$ : symmetric monoidal category fibered over  $\text{SMan}$ .

- Objects: Commutative diagrams

$$\begin{array}{ccccc}
 & & X & & \\
 & f_1 \nearrow & \uparrow f & \nwarrow f_0 & \\
 Y_1^c \subset Y_1 & \xrightarrow{i_1} & \Sigma & \xleftarrow{i_0} & Y_0 \supset Y_0^c \\
 & \searrow & \downarrow & \swarrow & \\
 & & S & & 
 \end{array}$$

where  $\Sigma$  is a Euclidean  $d|\delta$ -manifold and the conditions on  $\Sigma$  from the non-family version hold fiber-wise.

- Morphisms:
- Monoidal structure:
- Monoidal unit:

As one final remark, note that each point  $x \in X$  determines a functor  $d|\delta\text{-EB}^{fam} \rightarrow d|\delta\text{-EB}^{fam}(X)$  given by assigning to  $Y$  the pair  $(Y, x)$  where  $x$  denotes

the constant map to  $x \in X$ . Hence each  $d|\delta$ -EFT  $E$  over  $X$  determines a  $d|\delta$ -dimensional EFT by pre-composition with this functor.

28. EFT'S OF DIMENSIONS 0 AND 0|1

The goal of this lecture is to classify 0-dimensional EFT's and 0|1-dimensional EFT's over a manifold  $X$ . For the moment, let us fall back to the non-family definition: a 0-dimensional EFT over  $X$  is a functor  $E: 0\text{-EB}(X) \rightarrow \text{TV}$  where  $0\text{-EB}(X)$  and  $\text{TV}$  are categories internal to the strict 2-category  $\text{SymCat}$ .

There is only one object in  $0\text{-EB}(X)_0$ , namely  $\emptyset$ . The objects in  $0\text{-EB}(X)_1$  are 0-manifolds together with maps to  $X$ , i.e., a collection of points in  $X$ . Under  $E$

$$\text{pt} \amalg \dots \amalg \text{pt} \xrightarrow{f} X \quad \mapsto \quad E(f) \in \text{Hom}(E(\emptyset), E(\emptyset)) = \mathbb{C},$$

so it suffices to understand what  $E$  does to  $x: \text{pt} \rightarrow X$ , since  $E(f: \text{pt} \amalg \dots \amalg \text{pt} \rightarrow X) = \prod_{\ell=1}^k E(x_\ell)$  if  $x_1, \dots, x_k$  denote the points of  $X$  selected by  $f$ . Simply put, this is all of the information contained in the functor. In other words, it is completely determined by a choice of a function  $\hat{E}: X \rightarrow \mathbb{C}$  by sending  $x: \text{pt} \rightarrow X$  to  $\hat{E}(x)$ .

The 0-dimensional EFT's over  $X$  form a discrete category<sup>15</sup> equivalent to the discrete category  $\text{Maps}(X, \mathbb{C})$  whose objects are set maps  $X \rightarrow \mathbb{C}$ . In the final definition of a 0-EFT over  $X$  we demand that  $E$  be a functor  $0\text{-EB}^{fam}(X) \rightarrow \text{TV}^{fam}$ . The next proposition relates these full-blown field theories to the discrete category  $C^\infty(X, \mathbb{C})$  whose objects are smooth maps  $X \rightarrow \mathbb{C}$ .

**Proposition 28.1.** *The category  $0\text{-EFT}^{fam}(X)$  is equivalent the category  $C^\infty(X, \mathbb{C})$ .*

*Proof.* First we show how to construct from  $E \in 0\text{-EFT}^{fam}(X)$  a smooth function  $\hat{E} \in C^\infty(X, \mathbb{C})$ . The objects of  $0\text{-EB}^{fam}(X)_0$  are diagrams of the form

$$\begin{array}{ccc} \emptyset & \xrightarrow{f} & X \\ \downarrow & & \\ S & & \end{array}$$

where  $S$  is a smooth manifold. The value of  $E$  on such a diagram is simply the sheaf of smooth functions over  $S$ . Objects in  $0\text{-EB}^{fam}(X)_1$  are slightly more interesting diagrams of the form

$$(28.1) \quad \begin{array}{ccc} \Sigma & \xrightarrow{f} & X \\ \downarrow p & & \\ S & & \end{array}$$

where  $p: \Sigma \rightarrow S$  is a finite sheeted covering of  $S$ . The value of  $E$  on such a diagram is then an endomorphism of the sheaf of smooth functions on  $S$  and hence is just multiplication by a single smooth function on  $S$ .

<sup>15</sup>Only morphisms are identity morphisms.

Define  $\hat{E} \in C^\infty(X, \mathbb{C})$  to be the value of  $E$  on the diagram

$$\begin{array}{ccc} X \times \text{pt} & \xrightarrow{p} & X \\ \downarrow p & & \\ X & & \end{array}$$

where both the vertical and horizontal maps are the natural projections. In some sense, this is a universal object in  $0\text{-EB}^{fam}(X)_1$ .

Conversely, given a function  $g \in C^\infty(X, \mathbb{C})$ , we wish to define a functor  $E_g: 0\text{-EB}^{fam}(X) \rightarrow \text{TV}^{fam}$ . It is clear what needs to be done on  $0\text{-EB}^{fam}(X)_0$ . The interesting part is how we define  $E_g$  on objects of  $0\text{-EB}^{fam}(X)_1$  as in (28.1). As the value of  $E$  on such an object will be the operation of multiplication by a smooth function on the base space  $S$ , it suffices to specify its value at each point  $s \in S$ . The map  $p$  is a finite sheeted covering and the complex number we assign is the product

$$\prod_{\sigma \in p^{-1}(s)} g(f(\sigma)).$$

It remains to check that  $E_{\hat{E}} = E$ . This clearly holds on  $0\text{-EB}^{fam}(X)_0$ , but one needs to check that it holds on  $0\text{-EB}^{fam}(X)_1$ . There, both sides can be identified with smooth complex-valued functions over  $S$ . It is therefore sufficient to show that the values are the same point-wise over  $S$ .

Let  $S \in \text{Man}$  and let  $s \in \text{Man}(\text{pt}, S)$ , then we have a diagram

$$\begin{array}{ccc} & & X \\ & \nearrow f|_{p^{-1}(s)} & \uparrow f \\ p^{-1}(s) & \longrightarrow & E \\ \downarrow & & \downarrow p \\ \text{pt} & \xrightarrow{s} & S \end{array}$$

and since  $E$  is compatible with pull-backs, it suffices to show equality of  $E_{\hat{E}}(p^{-1}(s))$  and  $E(p^{-1}(s))$ . By definition  $E_{\hat{E}}(p^{-1}(s)) = \prod_{\sigma \in p^{-1}(s)} \hat{E}(f(\sigma))$  and due to the fact that  $E$  is a symmetric monoidal functor the value of  $E(p^{-1}(s))$  is the same.  $\square$

**Corollary 28.2.** *Nothing is gained in dimension 0 by passing to concordance classes.*

Let  $\Omega_{cl}^{ev}(X, \mathbb{C})$  denote the set of all closed complex-valued even differential forms on  $X$ , viewed as a discrete category.

**Theorem 28.3.** *The categories  $0|1\text{-EFT}^{fam}(X)$  and  $\Omega_{cl}^{ev}(X, \mathbb{C})$  are equivalent.*

A quick application of Stokes' theorem yields the following corollary.

**Corollary 28.4.** *There is a bijection  $0|1\text{-EFT}^{fam}[X] \leftrightarrow H_{dR}^{ev}(X; \mathbb{C})$ .*

*Proof of Theorem.* We will first extract a differential form on  $X$  from  $E \in 0|1\text{-EFT}(X)$  by evaluating  $E$  on a "universal object." Then we will use the Euclidean structure to argue that it is even and that it is closed.

First, some reductions. Recall that objects of  $0|1\text{-EB}^{fam}(X)_1$  are diagrams

$$\begin{array}{ccc} \Sigma & \xrightarrow{f} & X \\ \downarrow p & & \\ S & & \end{array}$$

where  $p$  is submersion with  $0|1$ -dimensional fibers equipped with a  $\text{Eucl}(\mathbb{R}^{0|1})$ -structure. It is sufficient to consider maps with fiber a single super point  $\mathbb{R}^{0|1}$  because of the monoidal structure. Furthermore, it is sufficient to consider trivial bundles by restriction to smaller open sets. Recall that  $\text{SMan}(\mathbb{R}^{0|1}, X)$  can be made into a super manifold  $\underline{\text{SMan}}(\mathbb{R}^{0|1}, X)$  by the internal-hom construction.

As before, the value of  $E$  on an object of  $0|1\text{-EB}^{fam}(X)$  can be identified with a smooth function on the base space  $S$ . Define  $\hat{E}$  to be the value of  $E$  on the object

$$\begin{array}{ccc} \underline{\text{SMan}}(\mathbb{R}^{0|1} \times X) \times \mathbb{R}^{0|1} & \xrightarrow{ev} & X \\ \downarrow & & \\ \underline{\text{SMan}}(\mathbb{R}^{0|1} \times X) & & \end{array}$$

then  $\hat{E} \in C^\infty(\underline{\text{SMan}}(\mathbb{R}^{0|1} \times X)) = C^\infty(\Pi(TX_{\mathbb{C}})) = \Omega^\bullet(X, \mathbb{C})$ .

Claim 1:  $\hat{E} \in \Omega^{ev}(X, \mathbb{C})$ .

Claim 2:  $d\hat{E} = 0$ .

These claims are proved by examining the action of automorphisms by the Euclidean group. Let  $G = \text{Eucl}(\mathbb{R}^{0|1}) = \mathbb{R}^{0|1} \rtimes \mathbb{Z}/2\mathbb{Z}$ . Now  $G$  acts on  $\mathbb{R}^{0|1}$  and hence acts on  $\underline{\text{SMan}}(\mathbb{R}^{0|1}, X)$  by pre-composition. The  $\mathbb{R}^{0|1}$  factor acts by “translations” and the generator of the  $\mathbb{Z}/2\mathbb{Z}$  factor acts by a transformation we will call “flip.” The action of the flip transformation on a smooth manifold  $M$  is the map  $\Omega(M) \rightarrow \Omega(M)$  given by  $\omega \mapsto (-1)^p \omega$  for  $\omega \in \Omega^p(M)$ . The translation action

$$\underline{\text{SMan}}(\mathbb{R}^{0|1}, X) \times \mathbb{R}^{0|1} \xrightarrow{\mu} \underline{\text{SMan}}(\mathbb{R}^{0|1}, X)$$

is given in terms of its action on functions

$$\Omega(X, \mathbb{C})[\theta] \xleftarrow{\mu^*} \Omega(X, \mathbb{C})$$

by  $\omega \mapsto \omega + d\omega \otimes \theta$ .

Write  $\underline{S}$  for  $\underline{\text{SMan}}(\mathbb{R}^{0|1}, X)$  for brevity. To prove claim 1, we apply the functor  $E$  to the commutative diagram

$$\begin{array}{ccc} X & \xlongequal{\quad} & X \\ \uparrow ev & & \uparrow ev \\ \underline{S} \times \mathbb{R}^{0|1} & \xrightarrow{\text{flip} \times \text{flip}} & \underline{S} \times \mathbb{R}^{0|1} \\ \downarrow & & \downarrow \\ \underline{S} & \xrightarrow{\text{flip}} & \underline{S} \end{array}$$

to obtain the equality  $\hat{E} = \text{flip}^*(\hat{E})$ , i.e.,  $\hat{E}$  is invariant under the action of the flip transformation. Thus  $\hat{E} \in \Omega^{ev}(X)$ .

To prove the second claim, we make the following important observation. The evaluation map  $\underline{S} \times \mathbb{R}^{0|1} \rightarrow X$  can be factored in two different ways. Recall that  $\mu: \mathbb{R}^{0|1} \times \mathbb{R}^{0|1} \rightarrow \mathbb{R}^{0|1}$  defines the group law on  $\mathbb{R}^{0|1}$ . Abusing notation, let  $\mu$  also denote the action map  $\underline{S} \times \mathbb{R}^{0|1} \rightarrow \underline{S}$  induced by pre-composition with  $\mu$ . Then  $\text{ev} \circ (\text{id} \times \mu) = \text{ev} \circ (\mu \times \text{id})$  and this gives us the following commutative diagram.

$$\begin{array}{ccc}
 X & \xlongequal{\quad} & X \\
 \uparrow & & \uparrow \text{ev} \\
 \underline{S} \times \mathbb{R}^{0|1} \times \mathbb{R}^{0|1} & \xrightarrow{\text{id} \times \mu} & \underline{S} \times \mathbb{R}^{0|1} \\
 \downarrow p_1 \times p_2 & \xrightarrow{\mu \times \text{id}} & \downarrow \\
 \underline{S} \times \mathbb{R}^{0|1} & \xrightarrow[p_1]{\mu} & \underline{S}
 \end{array}$$

Applying the functor  $E$  to this diagram gives a relation between the pull-backs of  $\hat{E}$  under the maps  $p_1$  and  $\mu$ , namely  $p_1^* \hat{E} = \mu^*(\hat{E})$ . But  $\mu^* \hat{E} = \hat{E} \otimes 1 + d\hat{E} \otimes \theta$  and  $p_1^* \hat{E} = \hat{E} \otimes 1$ , whence  $d\hat{E} = 0$ . This completes the proof.  $\square$

## 29. THE PARTITION FUNCTION OF A 2|1-EFT

The final lecture will be devoted to an outline of the proof of the following theorem.

**Theorem 29.1.** *The partition function of a 2|1-EFT is a weakly holomorphic integral modular form of weight zero.*

Let  $E$  be a 2|1-EFT. Recall that one can form a 2-dimensional Euclidean spin field theory  $\bar{E}$  from  $E$  by pre-composition with the superfication functor  $\zeta$ .

$$2\text{-EB}_{spin}^{fam} \xrightarrow{\zeta} 2|1\text{-EB}_{\bar{E}}^{fam} \xrightarrow{E} \text{TV}^{fam}$$

The ‘‘generalized partition function’’ of  $E$  was then defined to be  $Z_E = Z_{\bar{E}}: \mathbb{R}_+ \times \mathfrak{h} \rightarrow \mathbb{C}$  where  $Z_{\bar{E}}(\ell, \tau) \mapsto \bar{E}(\mathbb{C}/(\mathbb{Z} + \tau\mathbb{Z})\ell)$  is the value of  $\bar{E}$  on the Euclidean torus defined by  $\tau$  and  $\ell$ . Then the ‘‘ordinary partition function’’ is obtained by restriction to  $1 \times \mathfrak{h}$ .

Given an object  $Y \xleftarrow{\Sigma} Y$  of  $d|\delta\text{-EB}_1$ , we can always glue the ends to form a *closed* Euclidean super manifold  $\hat{\Sigma}$ . If  $E$  is a  $d|\delta\text{-EFT}$ , then<sup>16</sup>  $E(\hat{\Sigma}) = \text{str}(E(\Sigma))$ . Implicit in this fact is the statement that  $E(\Sigma)$  is trace class.

Now consider the family of Euclidean spin-bordisms of the circle to itself obtained from the parallelogram in the upper half-plane spanned by  $\ell$  and  $\ell\tau$  by identifying the two non-horizontal edges to obtain a cylinder  $C_{\ell, \tau}$ . The spin structure on  $C_{\ell, \tau}$  is meant to be that induced from the standard spin structure on  $\mathbb{C}$ . This family has the properties that  $C_{\ell, \tau+1} = C_{\ell, \tau}$  and  $C_{\ell, \tau} \circ C_{\ell, \tau'} = C_{\ell, \tau+\tau'}$  for each  $\ell \in \mathbb{R}_+$  and  $\tau \in \mathfrak{h}$ .

For fixed  $\ell$ ,  $\{\bar{E}(C_{\ell, \tau}): \tau \in \mathfrak{h}\}$  is a commuting family of trace class (and hence compact) operators depending only  $\tau$  modulo  $\mathbb{Z}$ , or equivalently depending only on  $q = e^{2\pi i\tau} \in \mathbb{D} \setminus \{0\}$ . This implies that  $\bar{E}(C_{\ell, \tau}) = q^{L_0} \bar{q}^{\bar{L}_0}$  where  $L_0$  and  $\bar{L}_0$

<sup>16</sup>Caveat: Assume that  $\Sigma^c$  is a  $d$ -manifold with boundary to eliminate the case of ‘‘thin’’ bordisms.

are unbounded operators with discrete spectrum. It is the case that the spectrum of  $L_0 - \bar{L}_0$  lies in  $\mathbb{Z}$ . Heuristically, one can imagine taking  $q \in \partial\mathbb{D} = S^1$ , then  $\bar{q} = q^{-1}$ , so  $q^{L_0 - \bar{L}_0}$  would be well-defined if and only if the spectrum of  $L_0 - \bar{L}_0$  was contained in  $\mathbb{Z}$ .

Let  $T_{\ell,\tau} = \mathbb{C}/(\mathbb{Z} + \tau\mathbb{Z})\ell$  denote the torus obtained from the cylinder  $C_{\ell,\tau}$  by identifying the ends, then  $\bar{E}(T_{\ell,\tau}) = \text{str } \bar{E}(C_{\ell,\tau})$ . We can compute this using the eigenspace decomposition of the vector space  $V = \bar{E}(S_\ell^1) = \bigoplus_{a,b} V_{a,b}$ ,  $a \in \text{Spec}(L_0)$ ,  $b \in \text{Spec}(\bar{L}_0)$ . With this decomposition

$$\text{str } \bar{E}(C_{\ell,\tau}) = \sum_{a,b} \text{str } \bar{E}(C_{\ell,\tau})|_{V_{a,b}} = \sum_{a,b} q^a \bar{q}^b \text{sdim } V_{a,b}$$

where  $a \in \text{Spec}(L_0)$  and  $b \in \text{Spec}(\bar{L}_0)$ .

**Key Fact:** If  $\bar{E}$  comes from a 2|1-EFT  $E$ , then  $\bar{L}_0 = \bar{G}_0^2$  where  $\bar{G}_0$  is an *odd* operator and  $L_0, \bar{L}_0$  and  $\bar{G}_0$  all commute in the graded sense.

Then  $\bar{G}_0: V_{a,b}^{ev} \rightarrow V_{a,b}^{odd}$  for each  $a, b$  and is an isomorphism unless  $b = 0$ . Therefore  $\text{sdim } V_{a,b} = 0$  unless  $b = 0$ . Hence

$$\text{str } \bar{E}(C_{\ell,\tau}) = \sum_a q^a \text{sdim } V_{a,0}$$

where  $a \in \text{Spec}(L_0) \subset \mathbb{Z}$ . Thus  $\bar{E}(T_{\ell,\tau})$  has an integral  $q$ -expansion in  $\mathbb{D} \setminus \{0\}$ . The only dependence of the sum on  $\ell$  is in the integers  $\text{sdim } V_{a,0}$  which depend continuously on  $\ell$  and are therefore constant.

If there are infinitely many eigenspaces  $V_{a,0}$  for negative  $a$  with  $\text{sdim } V_{a,0} \neq 0$ , then one obtains a contradiction to the compactness of  $\bar{E}(C_{\ell,\tau})$ . Thus  $Z_{\bar{E}}(1, \tau)$  is a holomorphic function of  $q$  in  $\mathbb{D} \setminus \{0\}$  with at worst a pole singularity at zero and an integral  $q$ -expansion.

The modularity of  $Z_{\bar{E}}(1, \tau)$  is an immediate consequence of the the isomorphism of Euclidean manifolds  $T_{|c\tau+d|\ell,\tau} \simeq T_{\ell,\tau}$  for

$$A = \begin{pmatrix} a & b \\ c & d \end{pmatrix} \in \text{SL}(2, \mathbb{Z}).$$

Indeed,

$$Z_{\bar{E}}(\ell, A\tau) = Z_{\bar{E}}(|c\tau+d|\ell, A\tau) = Z_{\bar{E}}(\ell, \tau).$$

Therefore  $Z_{\bar{E}}(1, \tau)$  transforms as a modular form of weight 0.

All that remains is to explain the Key Fact. Write  $\mathbb{R}_+^2$  for  $\mathfrak{h}$  regarded as a Lie semi-group. For fixed  $\ell$ ,  $\mathfrak{h}/\ell\mathbb{Z} = \mathbb{R}_+^2/\ell\mathbb{Z}$  can be regarded as the moduli space of cylinders because addition in the semi-group corresponds to gluing of cylinders. The functor  $\bar{E}$  yields a representation  $\mathbb{R}_+^2 \rightarrow \text{End}(V)$  of this Lie semi-group. The induced map on complexified Lie algebras sends the left-invariant complex vector fields  $\partial_z$  and  $\partial_{\bar{z}}$  to  $L_0$  and  $\bar{L}_0$ , respectively.

Analogously, there is a super Lie semi-group  $\mathbb{R}_+^{2|1}/\ell\mathbb{Z}$  of “(complex) super cylinders” and  $E$  gives a representation  $\mathbb{R}_+^{2|1} \rightarrow \text{End}(V)$ . Gluing of super-cylinders corresponds to the super-semigroup law on  $\mathbb{R}_+^{2|1}$  given by the physics formula

$$(z_1, \bar{z}_1, \theta_1), (z_2, \bar{z}_2, \theta_2) \mapsto (z_1 + z_2, \bar{z}_1 + \bar{z}_2 + \theta_1\theta_2, \theta_1 + \theta_2).$$

The super Lie algebra  $\text{Lie}(\mathbb{R}_+^{2|1})$  is spanned by the left-invariant vector fields on  $\mathbb{R}_+^{2|1}$ ,  $\partial_z, \partial_{\bar{z}}, Q$  where  $Q = \partial_\theta + \theta\partial_{\bar{z}}$ . Under  $E$ , these map to  $L_0, \bar{L}_0$ , and  $\bar{G}_0$ . Now observe that the graded commutator  $[Q, Q] = 2Q^2 = 2\partial_{\bar{z}}$ , so  $\bar{G}_0^2 = \bar{L}_0$ .

## REFERENCES

- [ABS] Atiyah, M.F., Bott, R., & Shapiro, A., *Clifford Modules*, Topology 3 (1964) suppl. 1, 3–38
- [B] Bauer, Tillman; *Computation of the homotopy of the spectrum tmf*, Geometry and Topology Monographs 13: Groups, homotopy and configuration spaces (Tokyo 2005), 2008, p. 11-40; arXiv: math/0311328
- [D] Deligne, P; *Courbe-elliptique* (1975)
- [KM] Katz, & Mazur, B., *Arithmetic Moduli of Elliptic Curves*, Annals of Mathematics Studies, Princeton University Press 1985
- [LM] Lawson, H. B. & Michelson, M.; *Spin Geometry*, Princeton University Press, 1990
- [MS] Milnor, J., & Stasheff, James; *Characteristic Classes*, Annals of Mathematics Studies 76, Princeton University Press, Princeton, New Jersey 1974