

Urs Schreiber

New York University Abu Dhabi
Center for Quantum & Topological
Systems

The \$1 Million Puzzle: Hadrons and Quantum Computers

Why Modern Physics Needs a New Global Mathematics





PARTICLE
PHYSICS



QUARKS IN A NUCLEUS

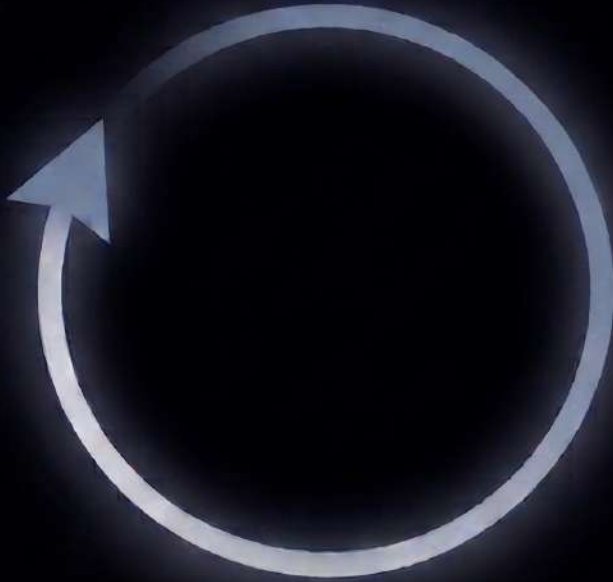

PARTICLE PHYSICS



QUARKS IN A NUCLEUS

SOLID STATE PHYSICS

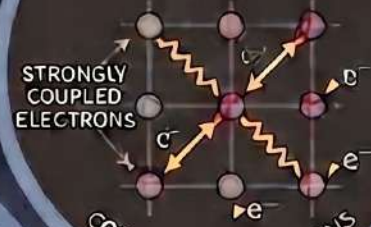

CORRELATED ELECTRONS



PARTICLE PHYSICS

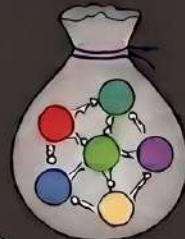

QUARKS IN A NUCLEUS

SOLID STATE PHYSICS

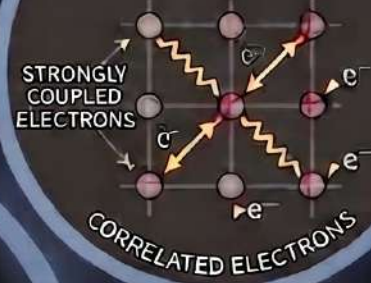

QUANTUM COMPUTING

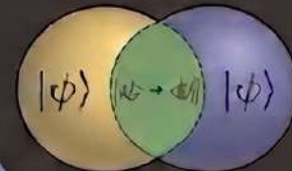

SUPERPOSITION STATES



PARTICLE PHYSICS

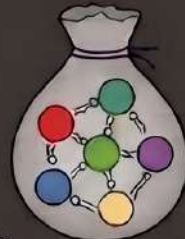

QUARKS IN A NUCLEUS

SOLID STATE PHYSICS

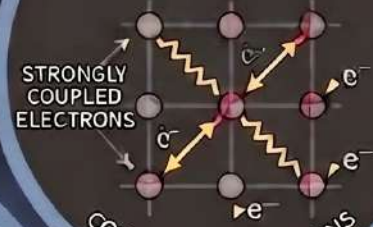

CORRELATED ELECTRONS

QUANTUM COMPUTING

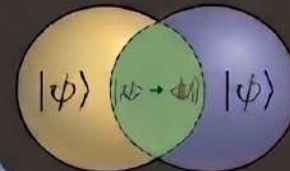

SUPERPOSITION STATES

TOPOLOGY

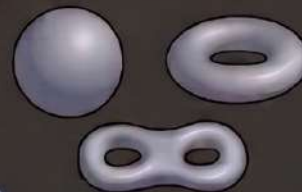

GENUS AND CONNECTIVITY

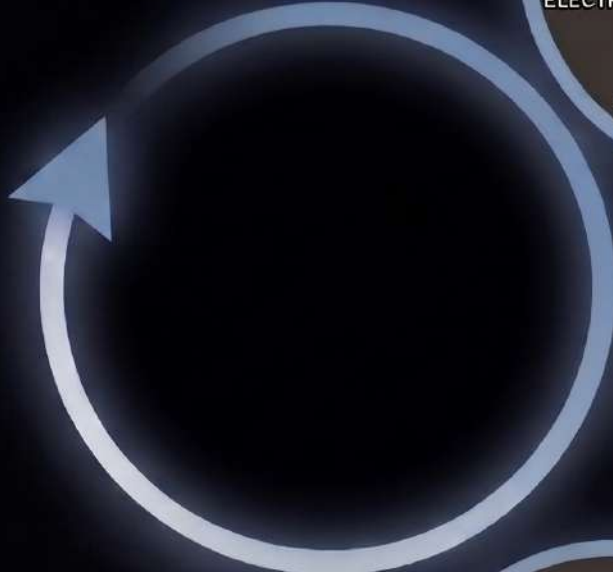

PARTICLE PHYSICS

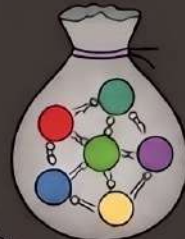

QUARKS IN A NUCLEUS

SOLID STATE PHYSICS

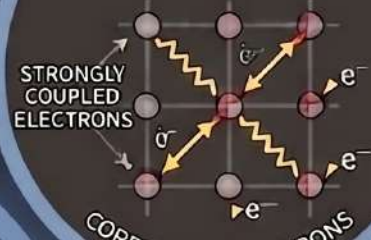

QUANTUM COMPUTING

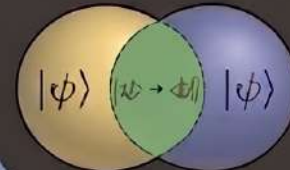

SUPERPOSITION STATES

HOMOTOPY THEORY



KNOT THEORY

TOPOLOGY

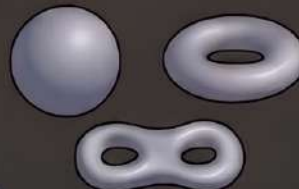

GENUS AND CONNECTIVITY



PARTICLE PHYSICS

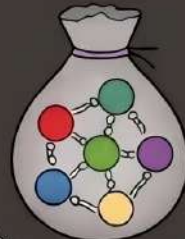

QUARKS IN A NUCLEUS

SOLID STATE PHYSICS

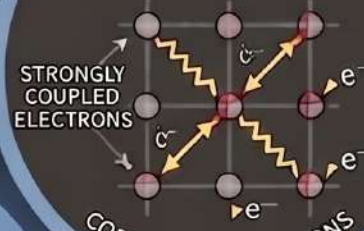

GEOMETRIC HOMOTOPY

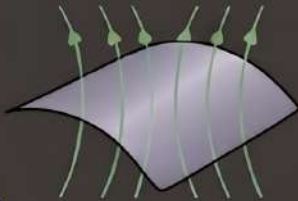

FLUX THROUGH SURFACES

HOMOTOPY THEORY



KNOT THEORY

TOPOLOGY

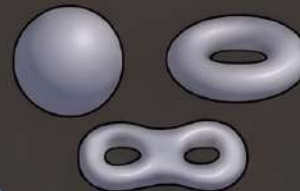

GENUS AND CONNECTIVITY

QUANTUM COMPUTING

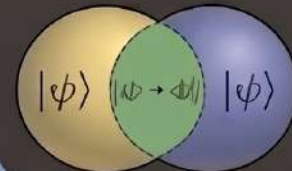

SUPERPOSITION STATES



PARTICLE PHYSICS

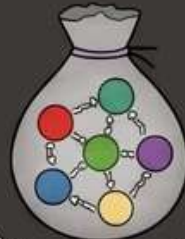

QUARKS IN A NUCLEUS

SOLID STATE PHYSICS

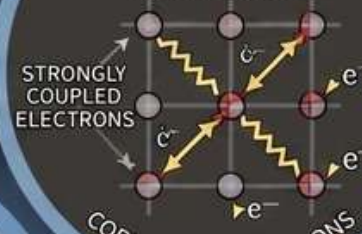

STRONGLY COUPLED ELECTRONS

CORRELATED ELECTRONS

HOMOTOPY TYPE THEORY

$$x_1 = x_2 : \text{Type}$$

IDENTITY TYPES

GEOMETRIC HOMOTOPY

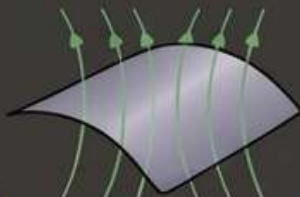

FLUX THROUGH SURFACES

HOMOTOPY THEORY

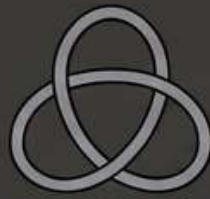

KNOT THEORY

TOPOLOGY

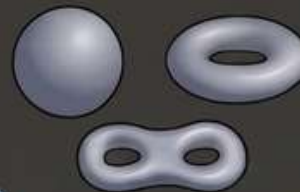

GENUS AND CONNECTIVITY

QUANTUM COMPUTING

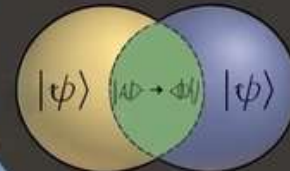

SUPERPOSITION STATES



The *standard model of particle physics*
says that, besides electrons,
matter is made of “*quarks*”:

The *standard model of particle physics* says that, besides electrons, matter is made of “*quarks*”:

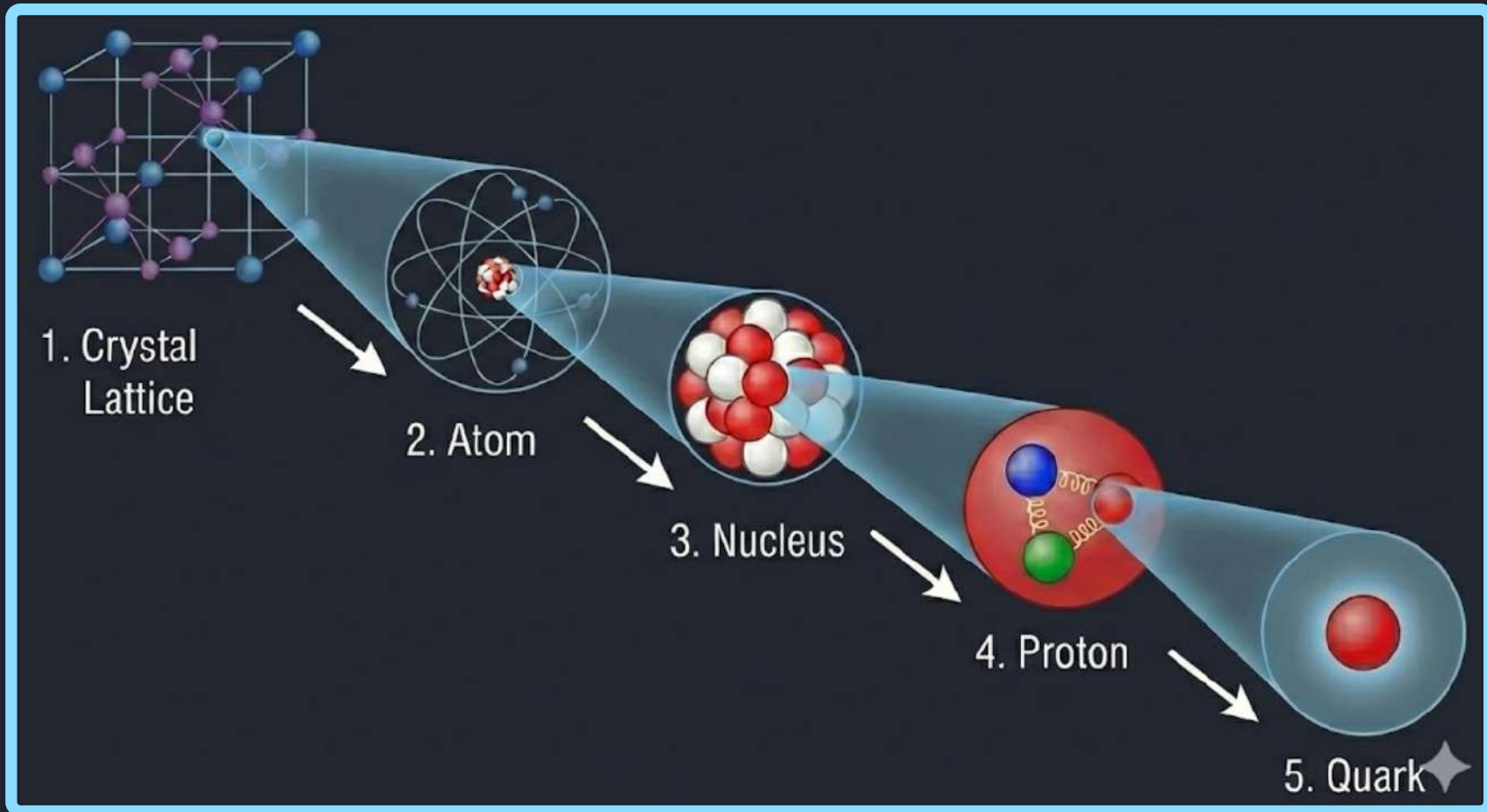

The *standard model of particle physics* says that, besides electrons, matter is made of “*quarks*”:

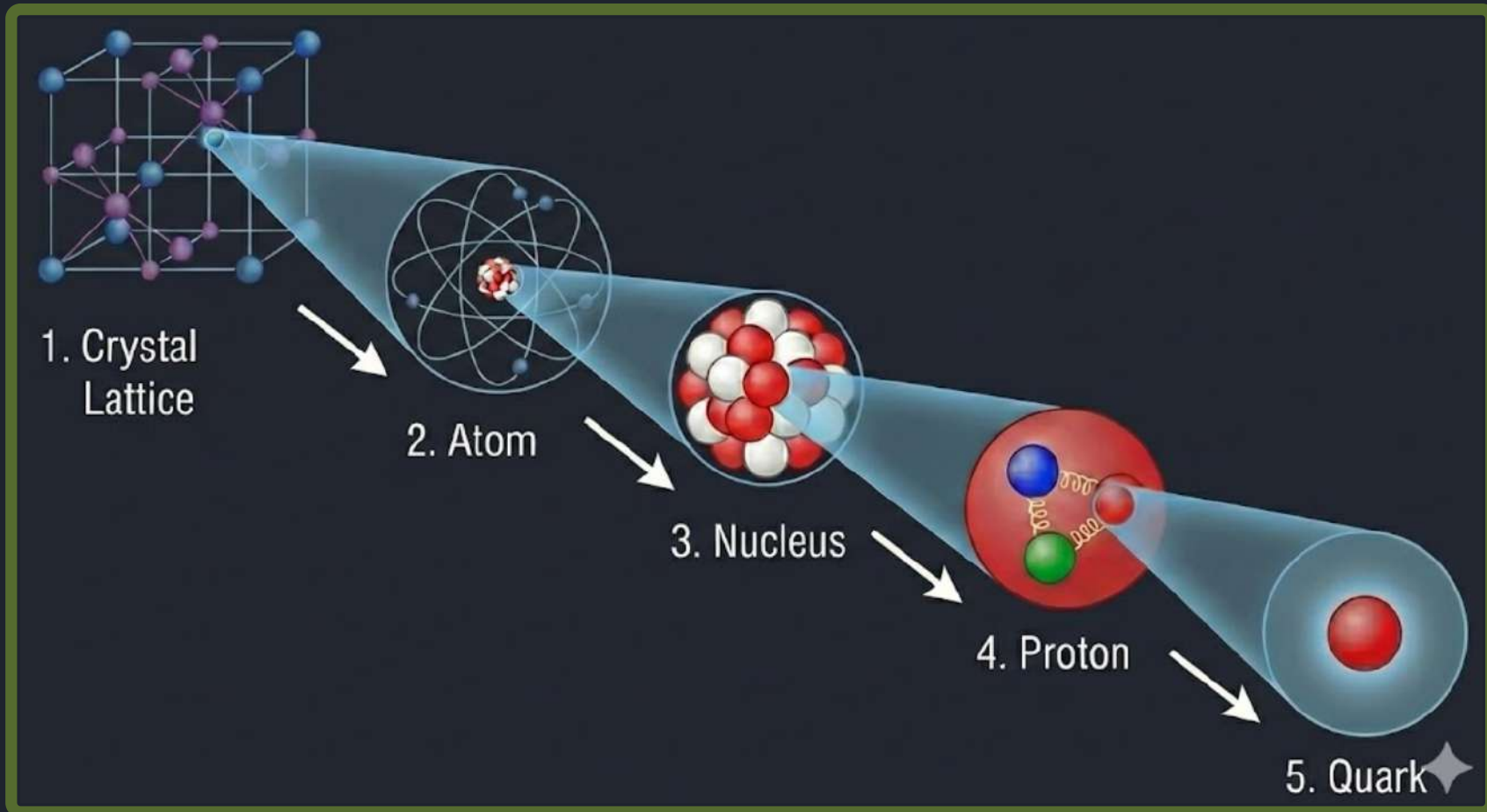

Generally, “*hadrons*”, like the proton, are thought to be *bound quarks*.

The *standard model of particle physics* says that, besides electrons, matter is made of “*quarks*”:

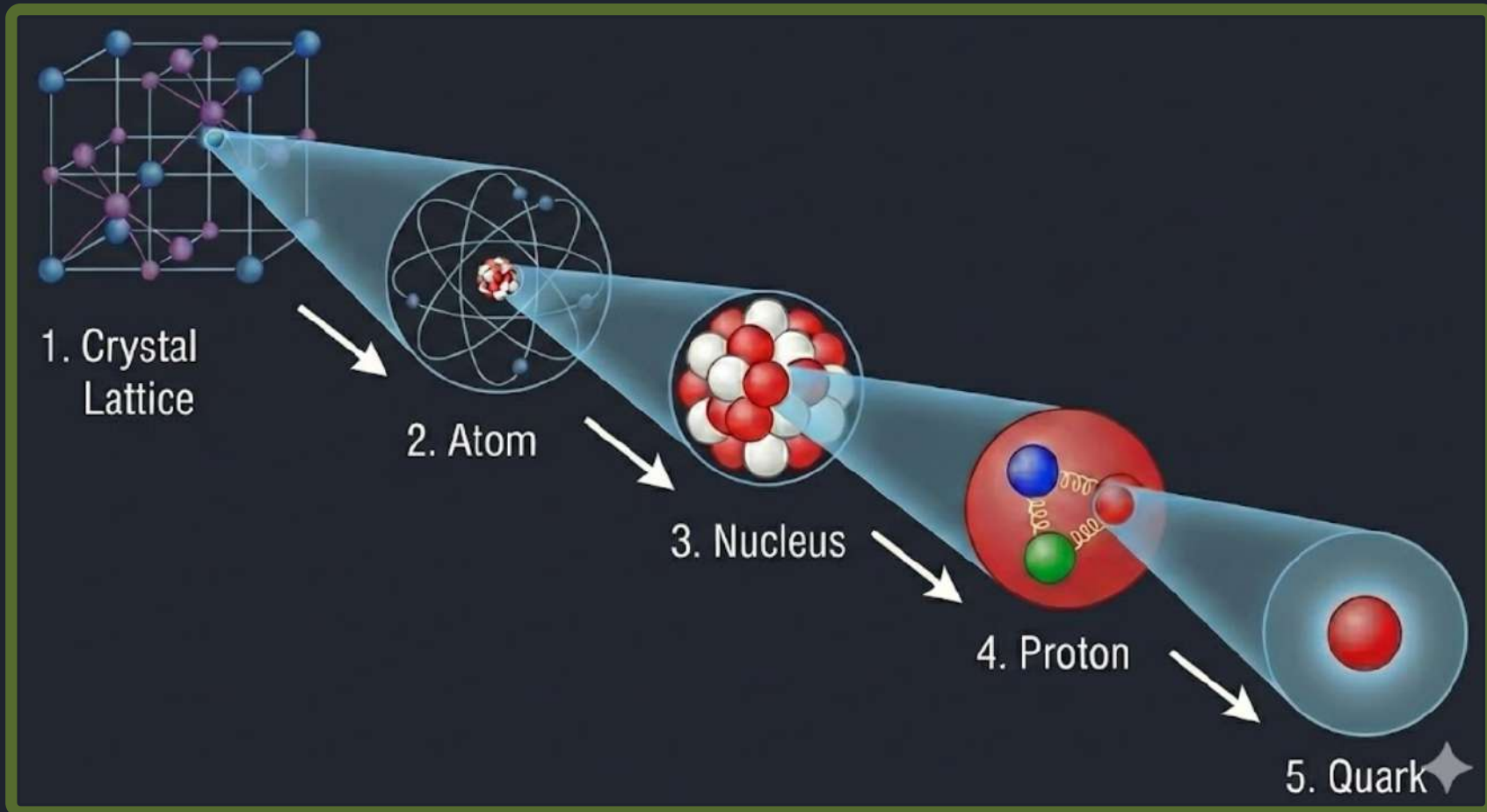

Generally, “*hadrons*”, like the proton, are thought to be *bound quarks*.

Popularizers say this standard model
leaves no room for improvement:

Popularizers say this standard model
leaves no room for improvement:

Woit 2006



Columbia Department of Mathematics

<https://www.math.columbia.edu> > ~woit > wordpress

The Trouble With Physics | Not Even Wrong

28 Aug 2006 — **The standard model is just too good.** It's too hard to find an experimental disagrees with it, and too hard to come up with ...

Popularizers say this standard model
leaves no room for improvement:

Woit 2006



Columbia Department of Mathematics

<https://www.math.columbia.edu> > ~woit > wordpress

The Trouble With Physics | Not Even Wrong

28 Aug 2006 — **The standard model is just too good.** It's too hard to find an experimental disagrees with it, and too hard to come up with ...

Dosch 2007

Phenomenology of elementary particles is, since 1980, in an excellent state. Presumably there are **more physicists who complain that the standard model is too good** than those who complain that it is too bad. The reason for that paradoxical behaviour is that the excellent agreement between theory and experiment leaves little space for evidence of 'new physics'.

Popularizers say this standard model
leaves no room for improvement:

Woit 2006



Columbia Department of Mathematics

<https://www.math.columbia.edu> > ~woit > wordpress

The Trouble With Physics | Not Even Wrong

28 Aug 2006 — **The standard model is just too good.** It's too hard to find an experimental disagrees with it, and too hard to come up with ...

Dosch 2007

Phenomenology of elementary particles is, since 1980, in an excellent state. Presumably there are **more physicists who complain that the standard model is too good** than those who complain that it is too bad. The reason for that paradoxical behaviour is that the excellent agreement between theory and experiment leaves little space for evidence of 'new physics'.

Siegel 2025

BIG THINK

Search

Topics

Videos

Columns

Classes

More

As 2025 ends, the Standard Model still
hasn't cracked

*Our Standard Model of the Universe, for both particle physics and cosmology,
remains intact for now. When will its foundations crack?*

Popularizers say this standard model leaves no room for improvement:

Woit 2006



Columbia Department of Mathematics

<https://www.math.columbia.edu> > ~woit > wordpress

The Trouble With Physics | Not Even Wrong

28 Aug 2006 — **The standard model is just too good.** It's too hard to find an experimental disagrees with it, and too hard to come up with ...

Dosch 2007

Phenomenology of elementary particles is, since 1980, in an excellent state. Presumably there are **more physicists who complain that the standard model is too good** than those who complain that it is too bad. The reason for that paradoxical behaviour is that the excellent agreement between theory and experiment leaves little space for evidence of 'new physics'.

Siegel 2025

BIG THINK

Search

Topics

Videos

Columns

Classes

More

As 2025 ends, the Standard Model still
hasn't cracked

*Our Standard Model of the Universe, for both particle physics and cosmology,
remains intact for now. When will its foundations crack?*

In particular, they say that experiments don't find particles not already predicted:

In particular, they say that experiments don't find particles not already predicted:

Wired 2016

A screenshot of a Wired article header. The top navigation bar features the Wired logo on the left, a hamburger menu icon, and a user profile icon with the text 'SUBSCRIBE' on the right. Below the navigation bar, the author's name 'BRENDAN COLE' is displayed in a white box, followed by the category 'SCIENCE' and the date 'AUG 5, 2016 8:02 AM'. The main headline is 'Sorry, Folks. The LHC Didn't Find a New Particle After All' in a large, bold, black font. Below the headline is a sub-headline: 'Physicists keeping on trying to prove the Standard Model wrong, and they keep failing.' with a small black diamond icon to its right.

W I R E D   SUBSCRIBE

BRENDAN COLE SCIENCE AUG 5, 2016 8:02 AM

Sorry, Folks. The LHC Didn't Find a New Particle After All

Physicists keeping on trying to prove the Standard Model wrong, and they keep failing. 

In particular, they say that experiments don't find particles not already predicted:

Wired 2016

A screenshot of a Wired article from 2016. The page has a dark background with white text. At the top left is the Wired logo, and at the top right is a 'SUBSCRIBE' button with a person icon. Below the logo, the author's name 'BRENDAN COLE' is in a white box, followed by the category 'SCIENCE' and the date 'AUG 5, 2016 8:02 AM'. The main headline is 'Sorry, Folks. The LHC Didn't Find a New Particle After All' in large, bold white font. Below the headline is a sub-headline: 'Physicists keeping on trying to prove the Standard Model wrong, and they keep failing.' with a small white star icon to the right.

Wired

BRENDAN COLE SCIENCE AUG 5, 2016 8:02 AM

Sorry, Folks. The LHC Didn't Find a New Particle After All

Physicists keeping on trying to prove the Standard Model wrong, and they keep failing.

Science 2022

A screenshot of a Science article from 2022. The page has a dark background with white text. At the top left, the categories 'NEWS | PHYSICS' are visible. The main headline is 'Ten years after the Higgs, physicists face the nightmare of finding nothing else' in large, bold white font. Below the headline is a sub-headline: 'Unless Europe's Large Hadron Collider coughs up a surprise, the field of particle physics may wheeze to its end'. At the bottom left, the date and time '13 JUN 2022 • 1:30 PM ET' and the author 'BY ADRIAN CHO' are listed. A small white star icon is in the bottom right corner.

NEWS | PHYSICS

Ten years after the Higgs, physicists face the nightmare of finding nothing else

Unless Europe's Large Hadron Collider coughs up a surprise, the field of particle physics may wheeze to its end

13 JUN 2022 • 1:30 PM ET • BY ADRIAN CHO

In particular, they say that experiments don't find particles not already predicted:

Wired 2016



The screenshot shows the top portion of a Wired article. At the top left is the Wired logo. To the right is a 'SUBSCRIBE' button with a person icon. Below the logo, the author's name 'BRENDAN COLE' is in a white box, followed by the category 'SCIENCE' and the date 'AUG 5, 2016 8:02 AM'. The main headline is 'Sorry, Folks. The LHC Didn't Find a New Particle After All'. Below the headline is a sub-headline: 'Physicists keeping on trying to prove the Standard Model wrong, and they keep failing.' A small star icon is in the bottom right corner of the article preview.

Wired

W I R E D

SUBSCRIBE

BRENDAN COLE SCIENCE AUG 5, 2016 8:02 AM

Sorry, Folks. The LHC Didn't Find a New Particle After All

Physicists keeping on trying to prove the Standard Model wrong, and they keep failing.

Science 2022

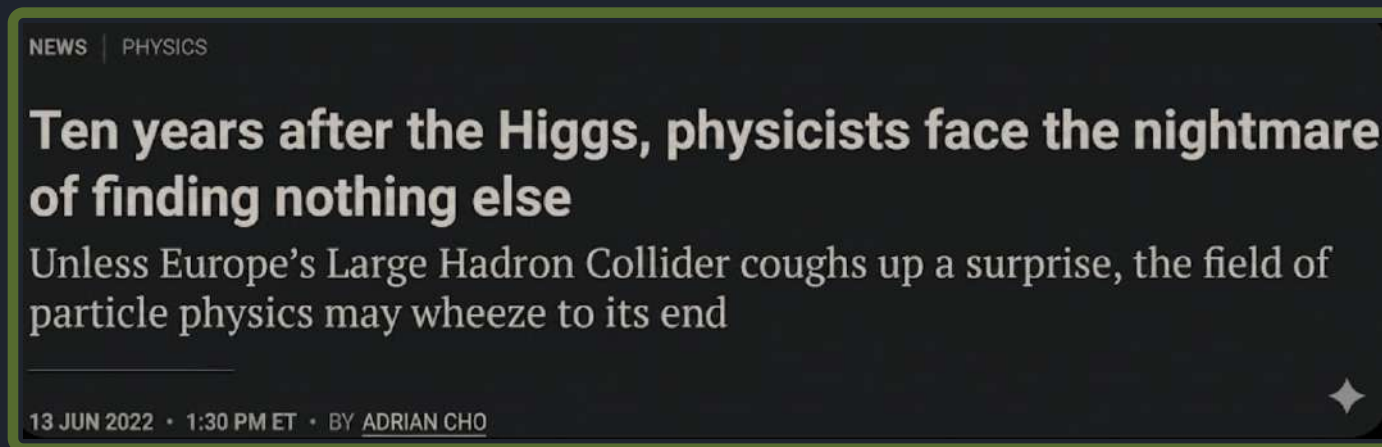

The screenshot shows the top portion of a Science article. At the top left, the categories 'NEWS | PHYSICS' are displayed. The main headline is 'Ten years after the Higgs, physicists face the nightmare of finding nothing else'. Below the headline is a sub-headline: 'Unless Europe's Large Hadron Collider coughs up a surprise, the field of particle physics may wheeze to its end'. At the bottom left, the date and time '13 JUN 2022 • 1:30 PM ET' and the author 'BY ADRIAN CHO' are listed. A small star icon is in the bottom right corner of the article preview.

NEWS | PHYSICS

Ten years after the Higgs, physicists face the nightmare of finding nothing else

Unless Europe's Large Hadron Collider coughs up a surprise, the field of particle physics may wheeze to its end

13 JUN 2022 • 1:30 PM ET • BY ADRIAN CHO

And yet, experiments find
unpredicted hadrons all the time:

And yet, experiments find
unpredicted hadrons all the time:

Koppenburg 2021-2026

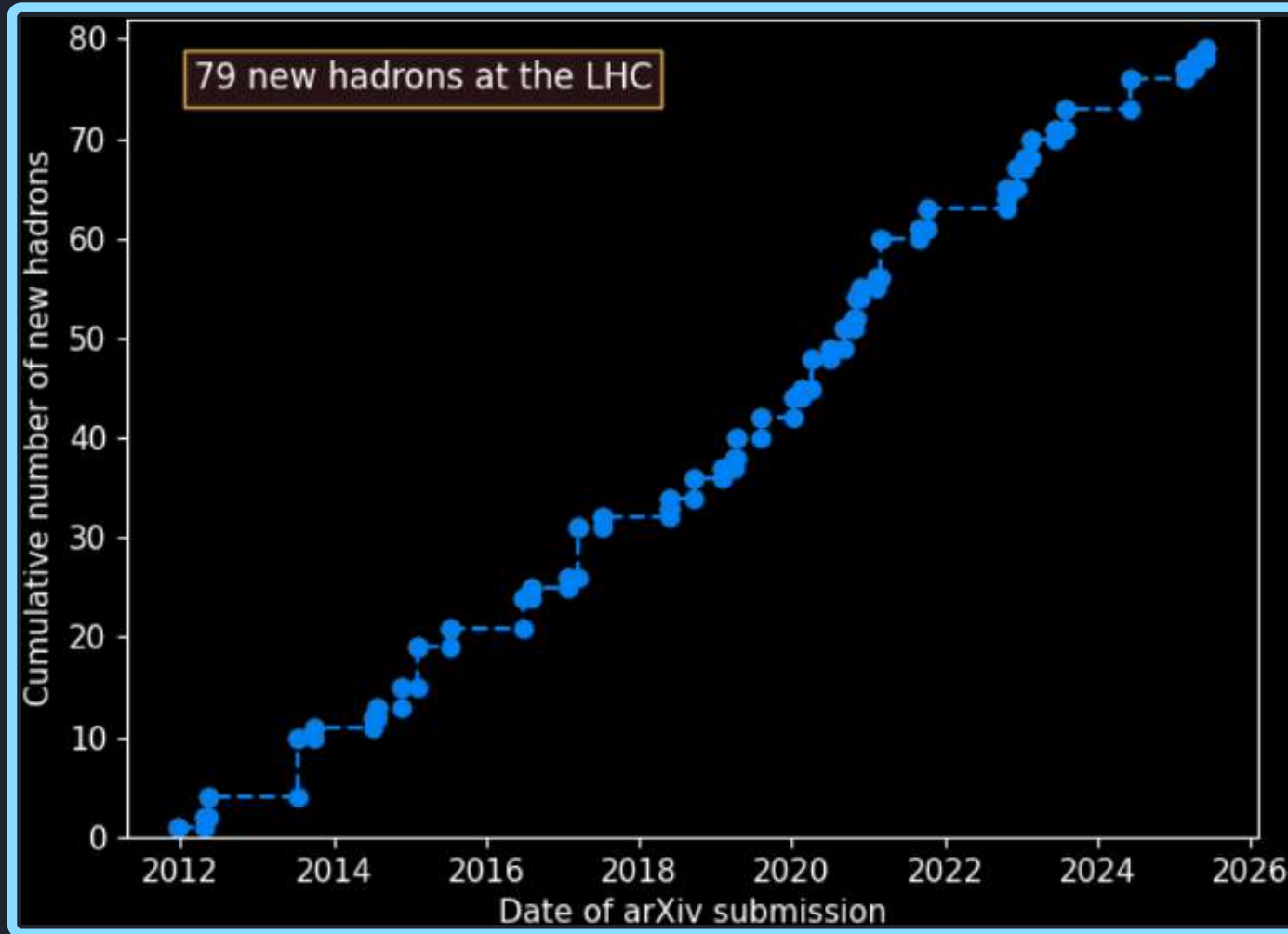

And yet, experiments find
unpredicted hadrons all the time:

Koppenburg 2021-2026

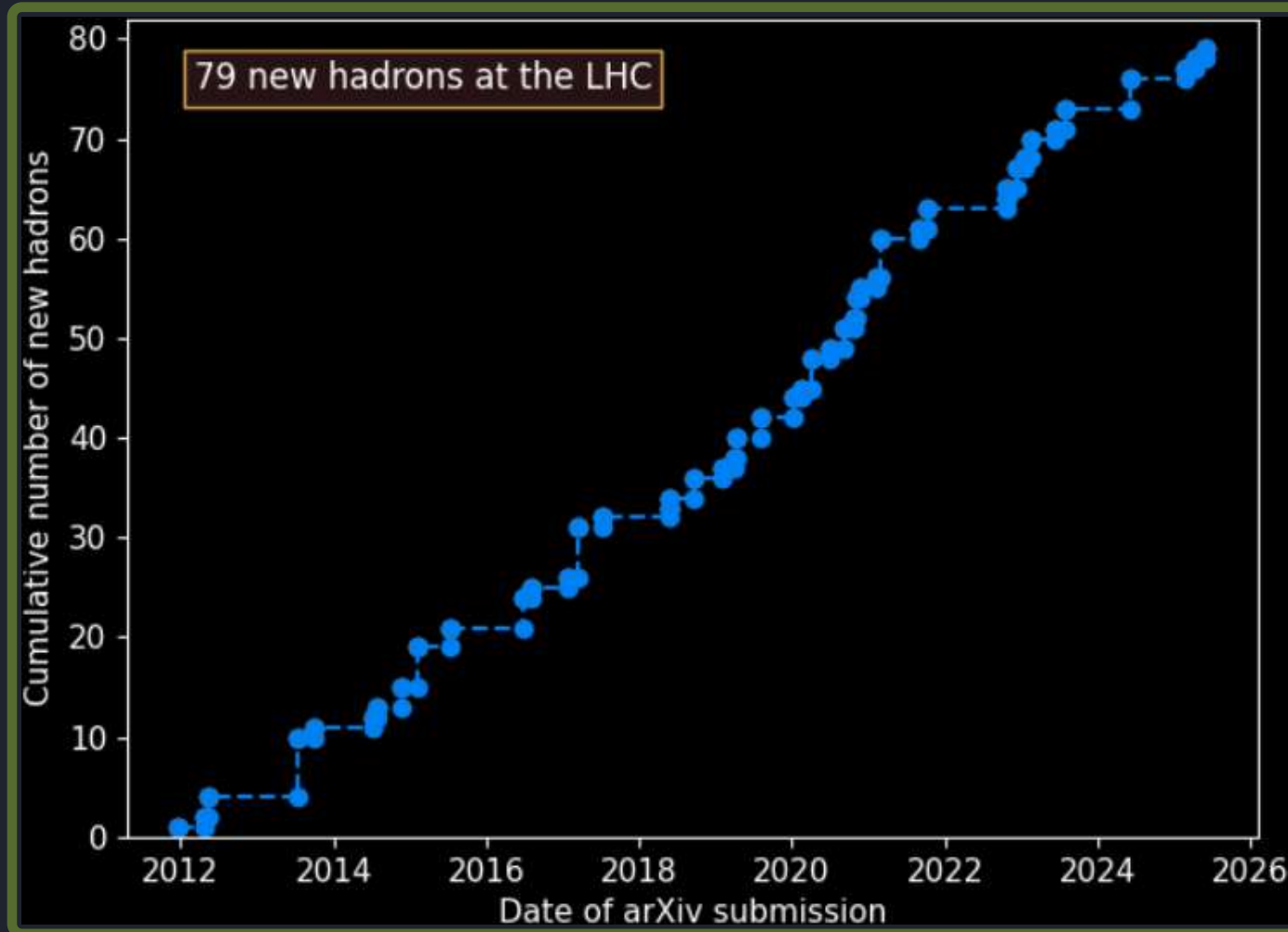

Although the QCD Lagrangian is expected to completely describe the spectrum of hadrons and all of their properties, there is no rigorous first-principle way of expressing this mathematically. The quark confinement conjecture is experimentally well tested, but mathematically still unproven. And it is still unknown which combinations of quarks may or may not form hadrons. **Experimental guidance is needed** to help improving theoretical models. These models are then in turn needed to constrain hadronic uncertainties which affect searches for New Physics phenomena.

And yet, experiments find
unpredicted hadrons all the time:

Koppenburg 2021-2026

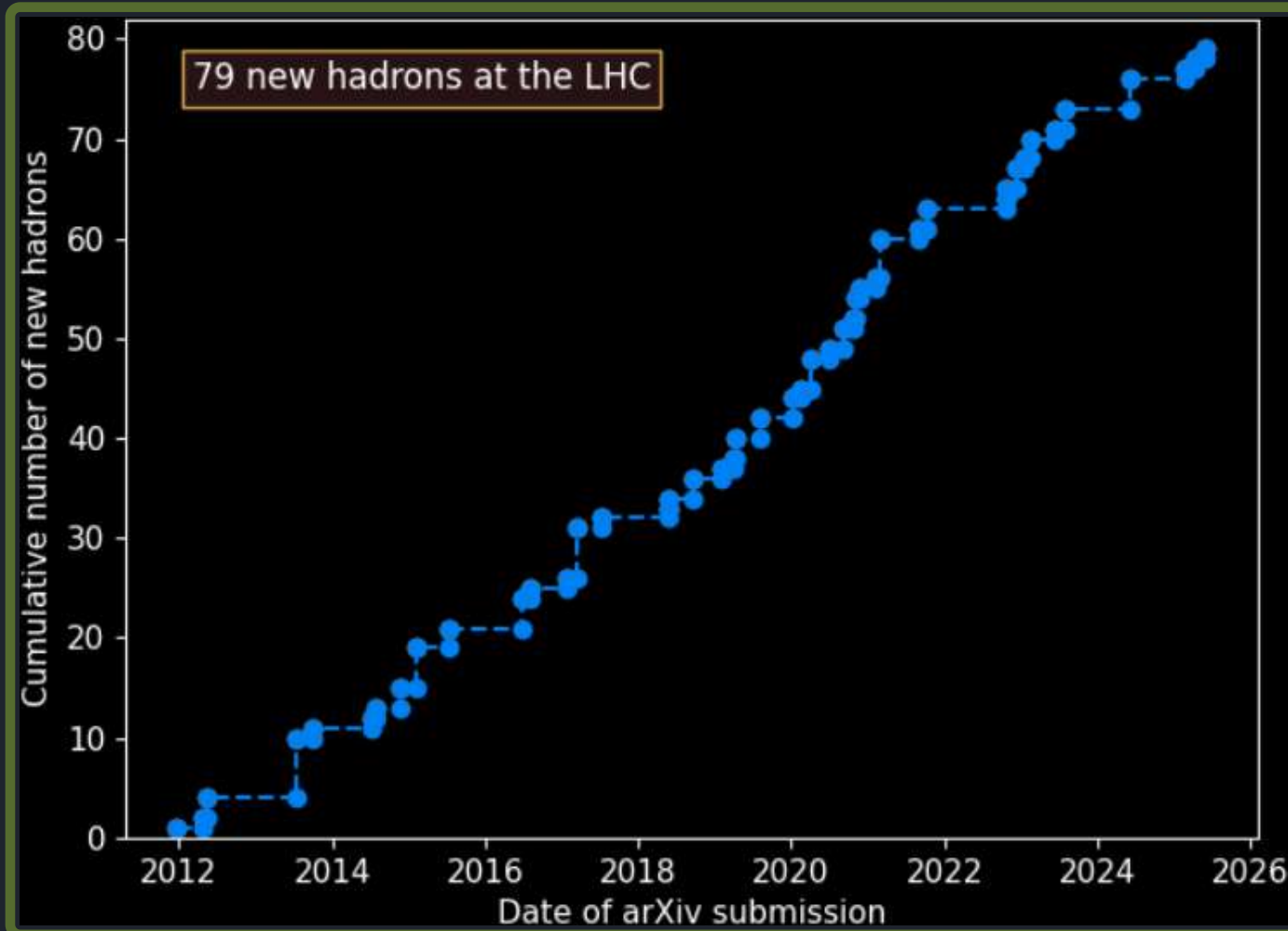

Although the QCD Lagrangian is expected to completely describe the spectrum of hadrons and all of their properties, there is no rigorous first-principle way of expressing this mathematically. The quark confinement conjecture is experimentally well tested, but mathematically still unproven. And it is still unknown which combinations of quarks may or may not form hadrons. **Experimental guidance is needed** to help improving theoretical models. These models are then in turn needed to constrain hadronic uncertainties which affect searches for New Physics phenomena.

Moreover, elusive hadron loop processes are known to mess up other “predictions” of the standard model:

Moreover, elusive hadron loop processes are known to mess up other “predictions” of the standard model:

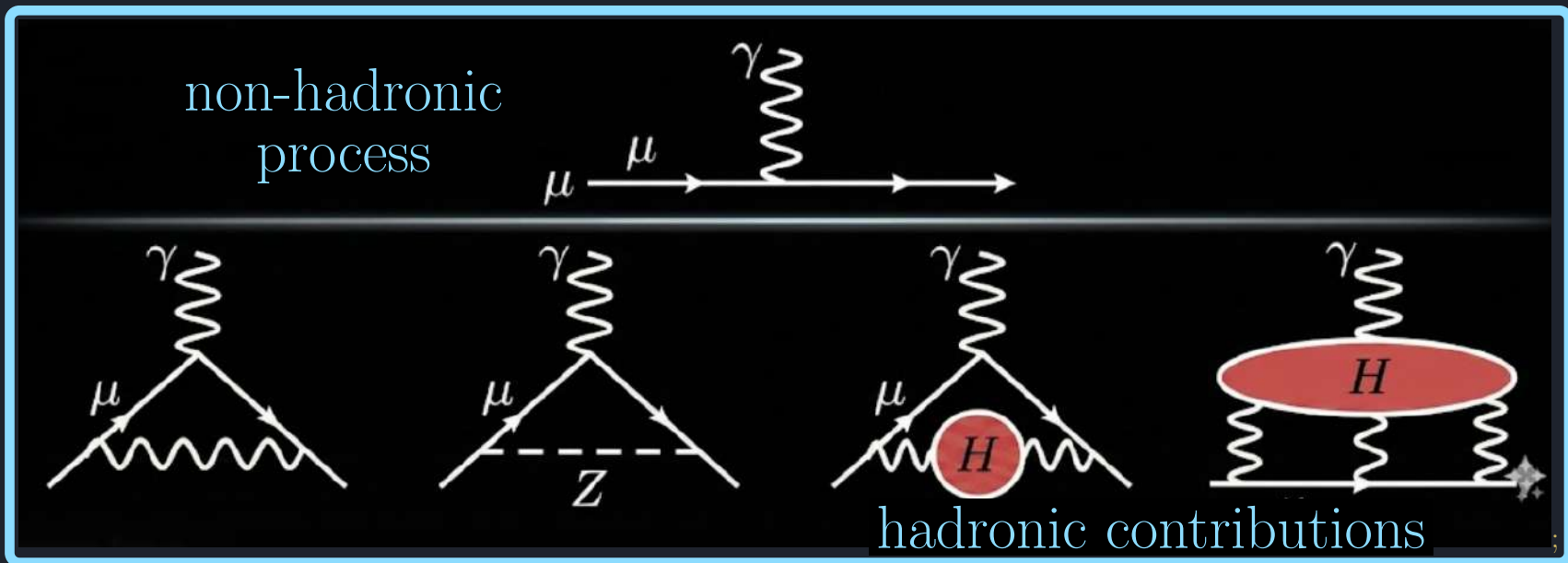

Moreover, elusive hadron loop processes are known to mess up other “predictions” of the standard model:

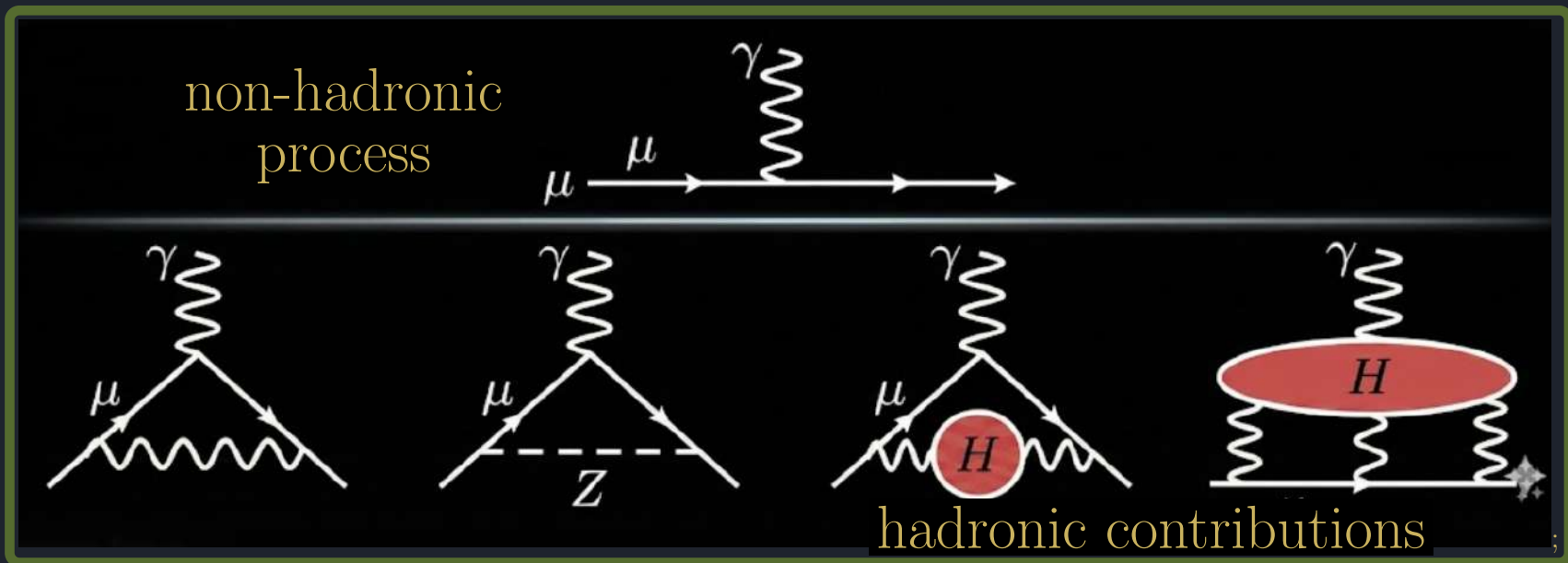

Moreover, elusive hadron loop processes are known to mess up other “predictions” of the standard model:

Reboud 2025

The screenshot shows a workshop page with the following elements:

- Title:** Taming hadronic uncertainties in and beyond the Standard Model
- Dates:** Oct 22–24, 2025
- Location:** IJCLab, Europe/Paris timezone
- Search:** A search bar with the placeholder text "Enter your search term".
- Navigation:** A sidebar menu with "Overview" and "Timetable" options.
- Main Content:** A paragraph starting with "Hadronic form factors remain one of the primary sources of uncertainty in flavour observables. This workshop aims to bring together the lattice, phenomenological and experimental communities to discuss the latest improvements in the calculation, description and use of these form factors."

Moreover, elusive hadron loop processes are known to mess up other “predictions” of the standard model:

Reboud 2025

Taming hadronic uncertainties in and beyond the Standard Model

Oct 22–24, 2025
IJCLab
Europe/Paris timezone

Enter your search term

- Overview
- Timetable
- Contributors

Hadronic form factors remain one of the primary sources of uncertainty in flavour observables. This workshop aims to bring together the lattice, phenomenological and experimental communities to discuss the latest improvements in the calculation, description and use of these form factors.

CernCourier 2026

Tensions remain

Essentially, all of the uncertainty in $g-2$ arises from the hadronic vacuum polarisation

Moreover, elusive hadron loop processes are known to mess up other “predictions” of the standard model:

Reboud 2025

Taming hadronic uncertainties in and beyond the Standard Model

Oct 22 – 24, 2025
IJCLab
Europe/Paris timezone

Enter your search term

- Overview
- Timetable

Hadronic form factors remain one of the primary sources of uncertainty in flavour observables. This workshop aims to bring together the lattice, phenomenological and experimental communities to discuss the latest improvements in the calculation, description and use of these form factors.

Cern Courier 2026

Tensions remain

Essentially, all of the uncertainty in $g-2$ arises from the hadronic vacuum polarisation

Athron et al. 2023

Hadronic uncertainties versus new physics for the W boson mass and μ on $g - 2$ anomalies

[Peter Athron](#) ✉, [Andrew Fowlie](#) ✉, [Chih-Ting Lu](#) ✉, [Lei Wu](#) ✉, [Yongcheng Wu](#) ✉ & [Bin Zhu](#) ✉

Nature Communications **14**, Article number: 659 (2023) | [Cite this article](#)

Moreover, elusive hadron loop processes are known to mess up other “predictions” of the standard model:

Reboud 2025

Taming hadronic uncertainties in and beyond the Standard Model

Oct 22 – 24, 2025
IJCLab
Europe/Paris timezone

Enter your search term

Overview
Timetable

Hadronic form factors remain one of the primary sources of uncertainty in flavour observables. This workshop aims to bring together the lattice, phenomenological and experimental communities to discuss the latest improvements in the calculation, description and use of these form factors.

Cern Courier 2026

Tensions remain

Essentially, all of the uncertainty in $g-2$ arises from the hadronic vacuum polarisation

Athron et al. 2023

Hadronic uncertainties versus new physics for the W boson mass and μ on $g - 2$ anomalies

Peter Athron , Andrew Fowlie , Chih-Ting Lu , Lei Wu , Yongcheng Wu  & Bin Zhu 

Nature Communications **14**, Article number: 659 (2023) | [Cite this article](#)

What gives?

Public secret:
Quarks are a peculiar theory.

What gives?

Public secret:
Quarks are a peculiar theory.

Individual quarks don't exist,

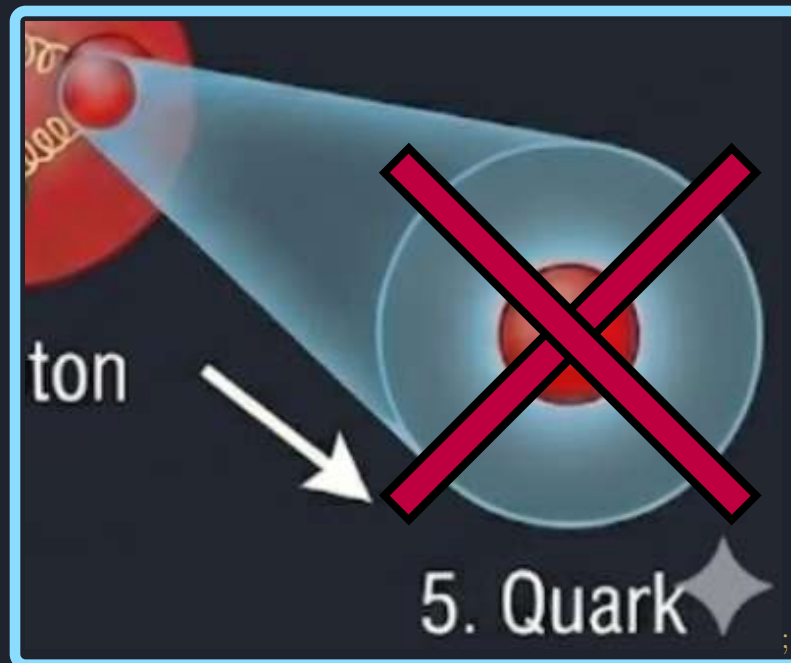

What gives?

Public secret:
Quarks are a peculiar theory.

Individual quarks don't exist,
only quarks bound in hadrons exist,

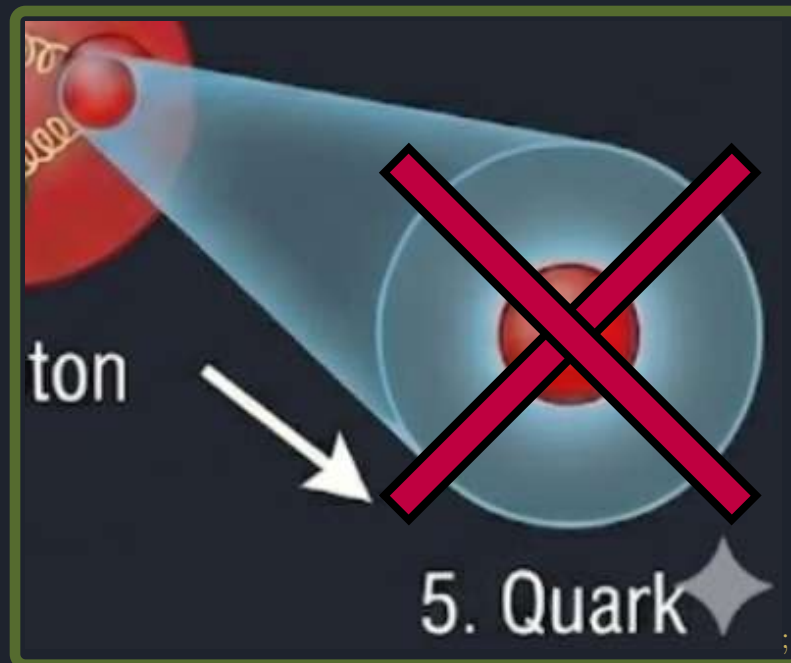

What gives?

Public secret:
Quarks are a peculiar theory.

Individual quarks don't exist,
only quarks bound in hadrons exist,
but the way they bind is *not explained!*

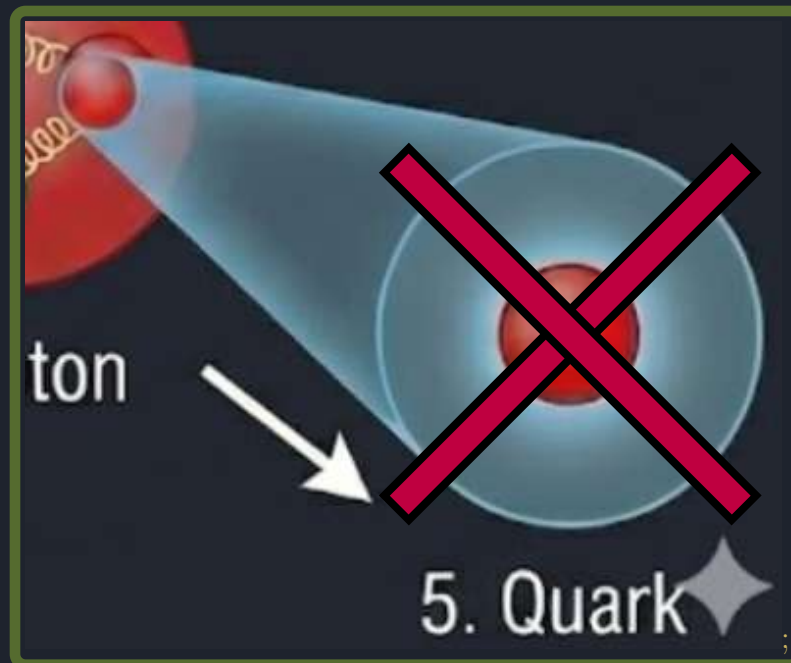

What gives?

Public secret:
Quarks are a peculiar theory.

Individual quarks don't exist,
only quarks bound in hadrons exist,
but the way they bind is *not explained!*

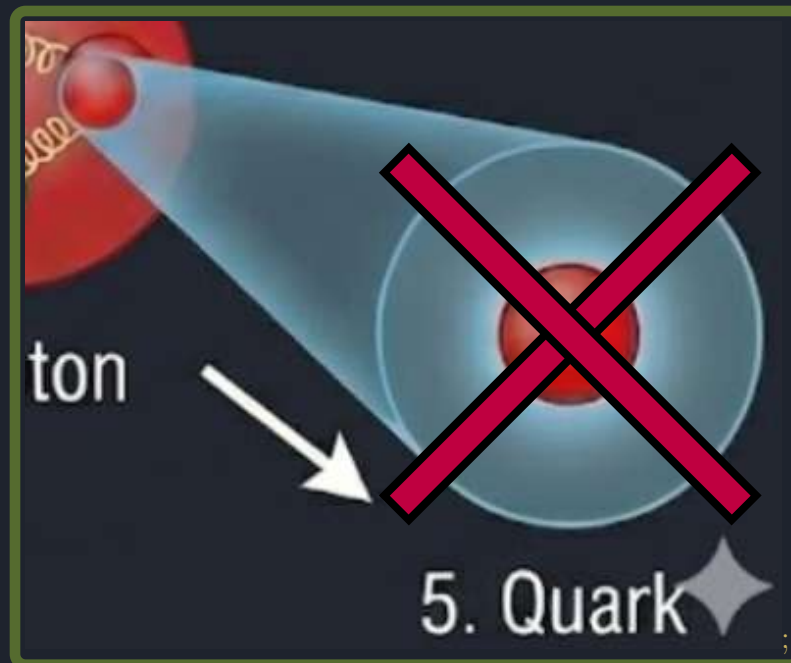

The attitude in particle physics is that:

*“The standard model explains hadrons **in principle**.”*

The attitude in particle physics is that:
*“The standard model explains hadrons **in principle**.”*

But **in practice** it barely does: instead
various rules-of-thumb are used:

The attitude in particle physics is that:
*“The standard model explains hadrons **in principle**.”*

But **in practice** it barely does: instead
various rules-of-thumb are used:

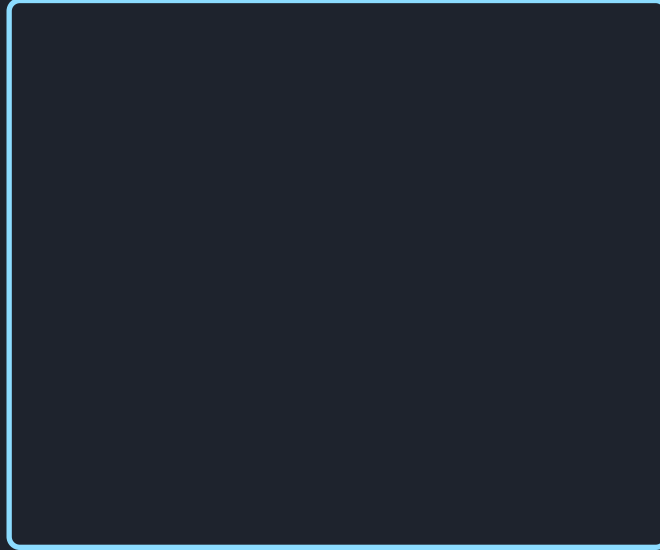

The attitude in particle physics is that:
“*The standard model explains hadrons in principle.*”

But *in practice* it barely does: instead
various rules-of-thumb are used:

*Chiral Perturbation theory,
Constituent Quark Model,*

The attitude in particle physics is that:
“*The standard model explains hadrons in principle.*”

But *in practice* it barely does: instead
various rules-of-thumb are used:

*Chiral Perturbation theory,
Constituent Quark Model,
Nambu-Jona-Lasinio model,*

The attitude in particle physics is that:
“*The standard model explains hadrons in principle.*”

But *in practice* it barely does: instead
various rules-of-thumb are used:

*Chiral Perturbation theory,
Constituent Quark Model,
Nambu-Jona-Lasinio model,
Heavy Quark Effective Theory,*

The attitude in particle physics is that:
“*The standard model explains hadrons in principle.*”

But *in practice* it barely does: instead
various rules-of-thumb are used:

*Chiral Perturbation theory,
Constituent Quark Model,
Nambu-Jona-Lasinio model,
Heavy Quark Effective Theory,
Skyrme model,*

The attitude in particle physics is that:
“*The standard model explains hadrons in principle.*”

But *in practice* it barely does: instead
various rules-of-thumb are used:

*Chiral Perturbation theory,
Constituent Quark Model,
Nambu-Jona-Lasinio model,
Heavy Quark Effective Theory,
Skyrme model,
QCD Sum Rules,*

The attitude in particle physics is that:
“*The standard model explains hadrons in principle.*”

But *in practice* it barely does: instead
various rules-of-thumb are used:

*Chiral Perturbation theory,
Constituent Quark Model,
Nambu-Jona-Lasinio model,
Heavy Quark Effective Theory,
Skyrme model,
QCD Sum Rules,
Bag Models,*

The attitude in particle physics is that:
“*The standard model explains hadrons in principle.*”

But *in practice* it barely does: instead
various rules-of-thumb are used:

*Chiral Perturbation theory,
Constituent Quark Model,
Nambu-Jona-Lasinio model,
Heavy Quark Effective Theory,
Skyrme model,
QCD Sum Rules,
Bag Models,
Holographic QCD,*

The attitude in particle physics is that:
“*The standard model explains hadrons in principle.*”

But *in practice* it barely does: instead
various rules-of-thumb are used:

*Chiral Perturbation theory,
Constituent Quark Model,
Nambu-Jona-Lasinio model,
Heavy Quark Effective Theory,
Skyrme model,
QCD Sum Rules,
Bag Models,
Holographic QCD,
...*

The attitude in particle physics is that:
“*The standard model explains hadrons in principle.*”

But *in practice* it barely does: instead
various rules-of-thumb are used:

*Chiral Perturbation theory,
Constituent Quark Model,
Nambu-Jona-Lasinio model,
Heavy Quark Effective Theory,
Skyrme model,
QCD Sum Rules,
Bag Models,
Holographic QCD,
...*

This is not entirely unlike alchemy.

The attitude in particle physics is that:
“*The standard model explains hadrons in principle.*”

But *in practice* it barely does: instead
various rules-of-thumb are used:

*Chiral Perturbation theory,
Constituent Quark Model,
Nambu-Jona-Lasinio model,
Heavy Quark Effective Theory,
Skyrme model,
QCD Sum Rules,
Bag Models,
Holographic QCD,
...*

This is not entirely unlike alchemy.

Elephant in the room:

Hadrons are *non-perturbative* effects:
not just small perturbations of the vacuum.

Elephant in the room:

Hadrons are *non-perturbative* effects:
not just small perturbations of the vacuum.

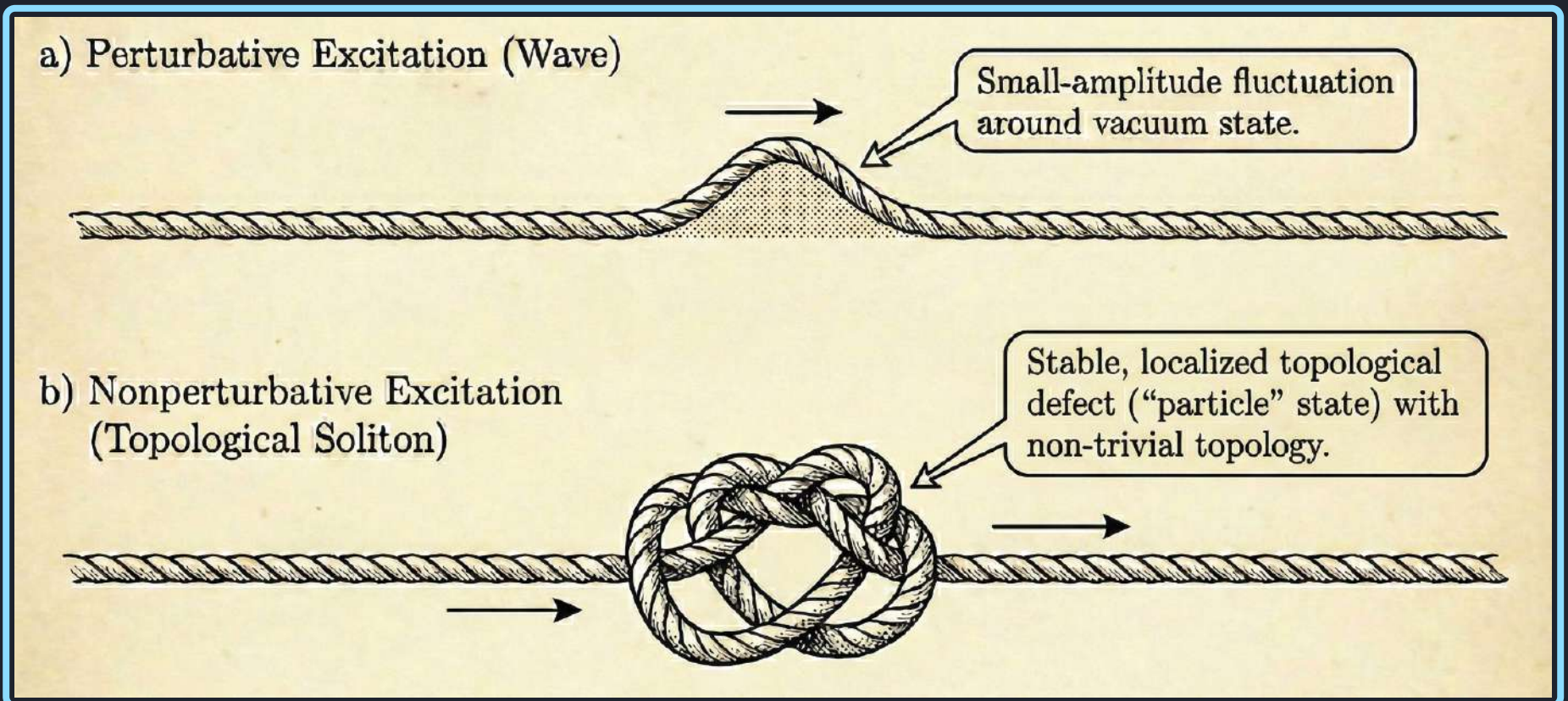

Elephant in the room:

Hadrons are *non-perturbative* effects:
not just small perturbations of the vacuum.

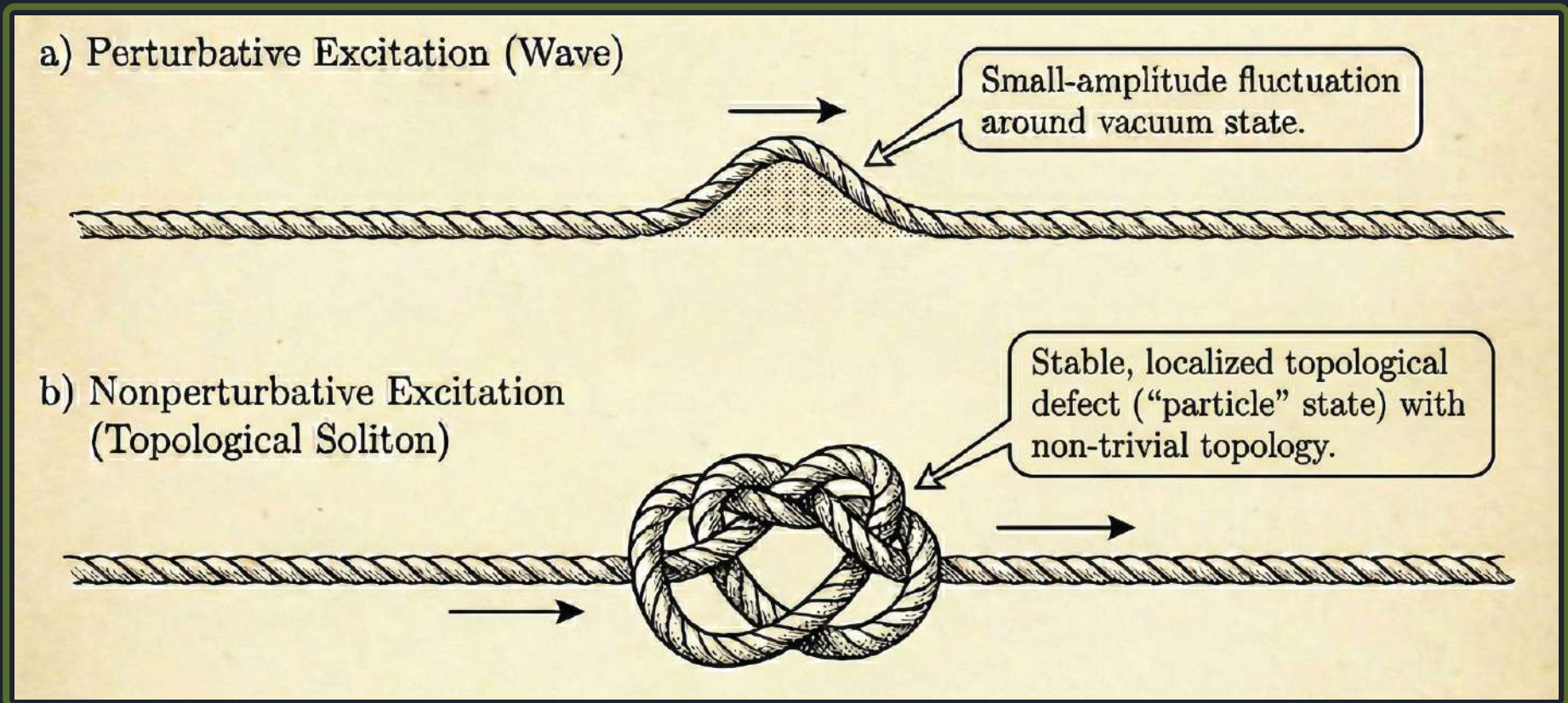

But 20th century quantum field theory
was predominantly perturbative,

But 20th century quantum field theory
was predominantly perturbative,
seeing only an infinitesimal neighbourhood
in the space of all quantum phenomena

But 20th century quantum field theory
was predominantly perturbative,
seeing only an infinitesimal neighbourhood
in the space of all quantum phenomena

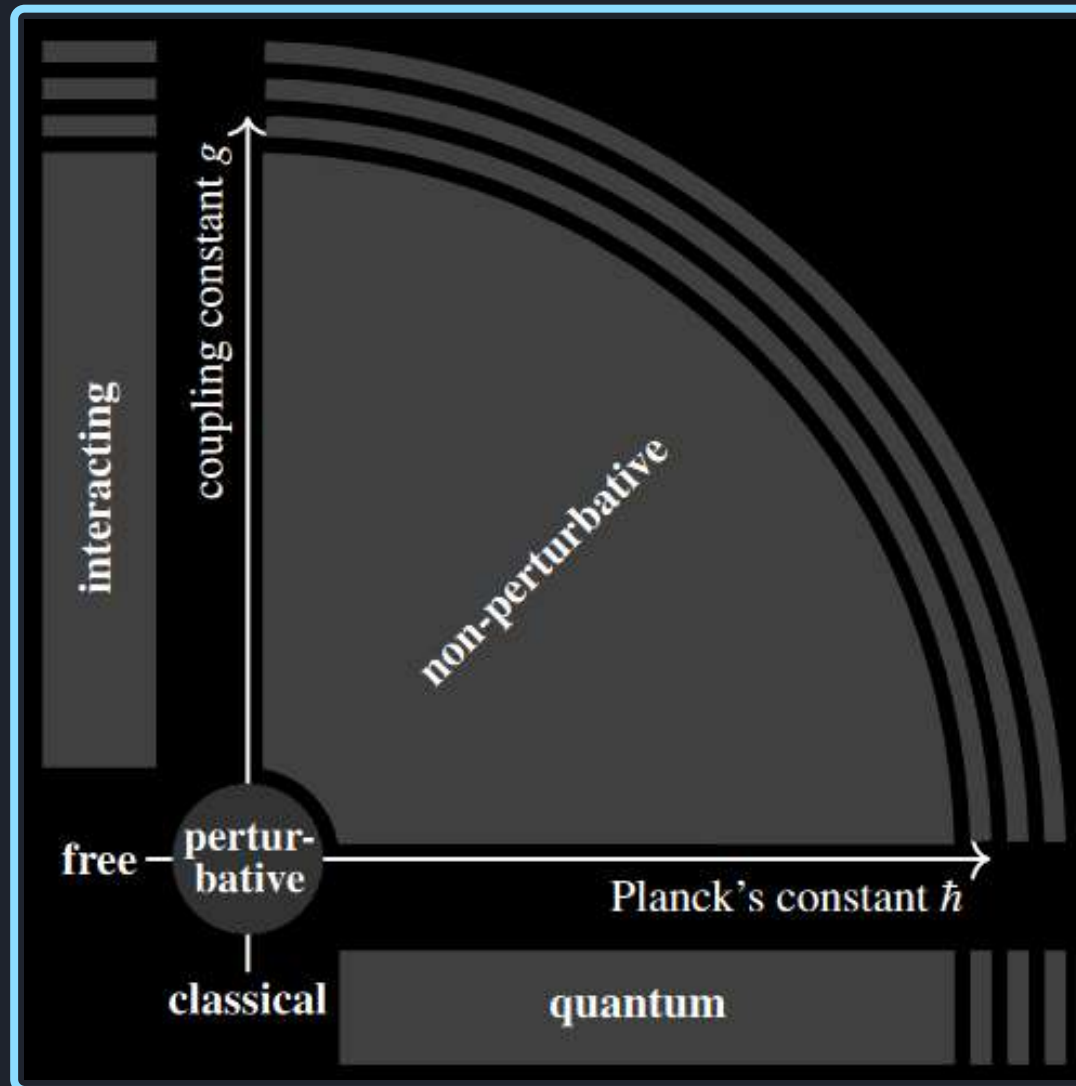

But 20th century quantum field theory
was predominantly perturbative,
seeing only an infinitesimal neighbourhood
in the space of all quantum phenomena

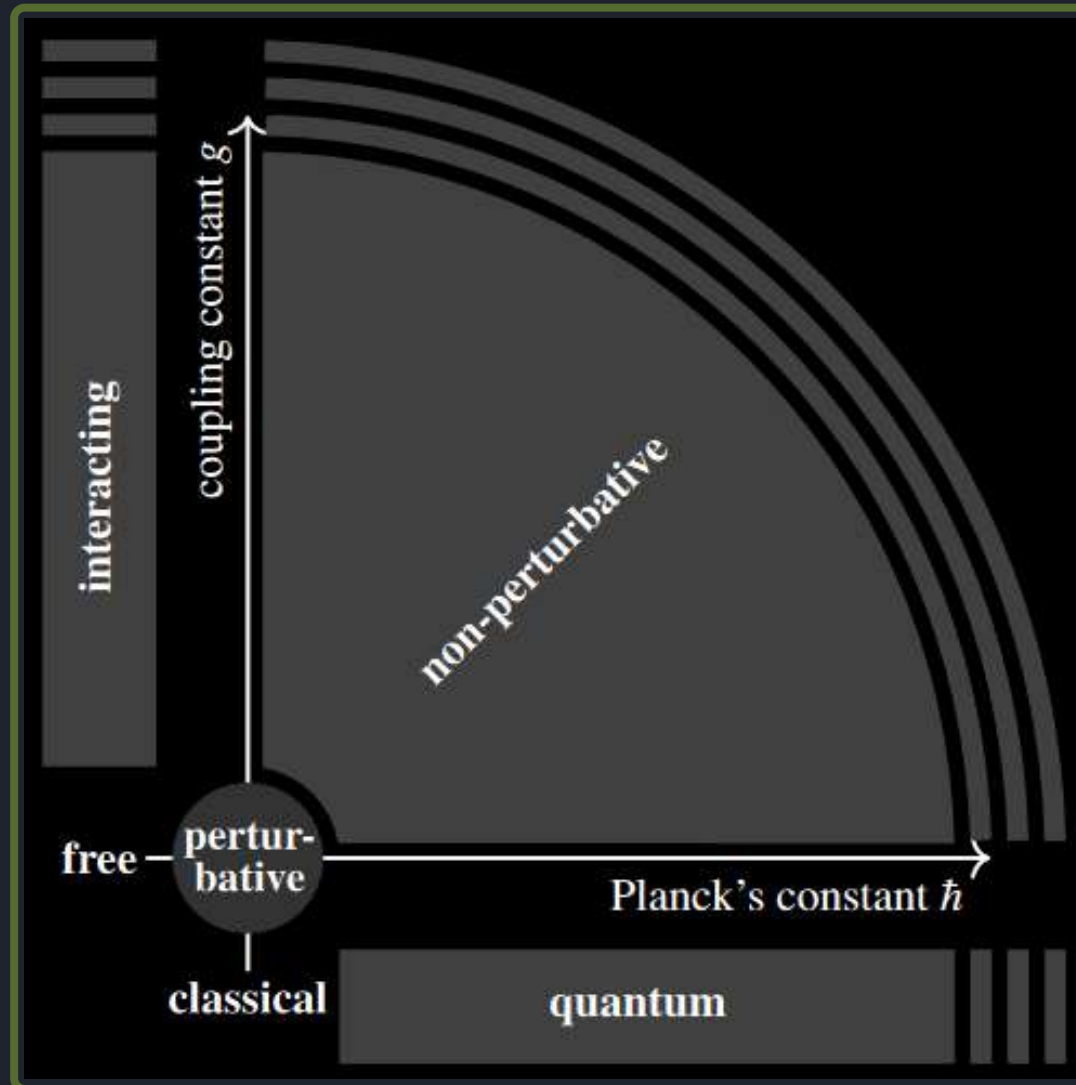

The *Clay Math Institute* has declared the
non-perturbative formulation of hadrons
to be a *Millennium Problem* in mathematics

The *Clay Math Institute* has declared the
non-perturbative formulation of hadrons*
to be a *Millennium Problem* in mathematics

* More precisely, CMI is first of all asking
for rigorous derivation of “*glueballs*”,
which are cousins of hadrons.

The *Clay Math Institute* has declared the non-perturbative formulation of hadrons* to be a *Millennium Problem* in mathematics and offers \$ 1 Million prize money



* More precisely, CMI is first of all asking for rigorous derivation of “glueballs”, which are cousins of hadrons.

While a proof of quark confinement in hadrons remains wide open,
a suggestive *heuristic* picture has solidified over the decades:

While a proof of quark confinement in hadrons remains wide open, a suggestive *heuristic* picture has solidified over the decades:

There are “color” *flux lines* between quarks, compressed to a *flux tube/string*, which binds them together.

While a proof of quark confinement in hadrons remains wide open, a suggestive *heuristic* picture has solidified over the decades:

There are “color” *flux lines* between quarks, compressed to a *flux tube/string*, which binds them together.

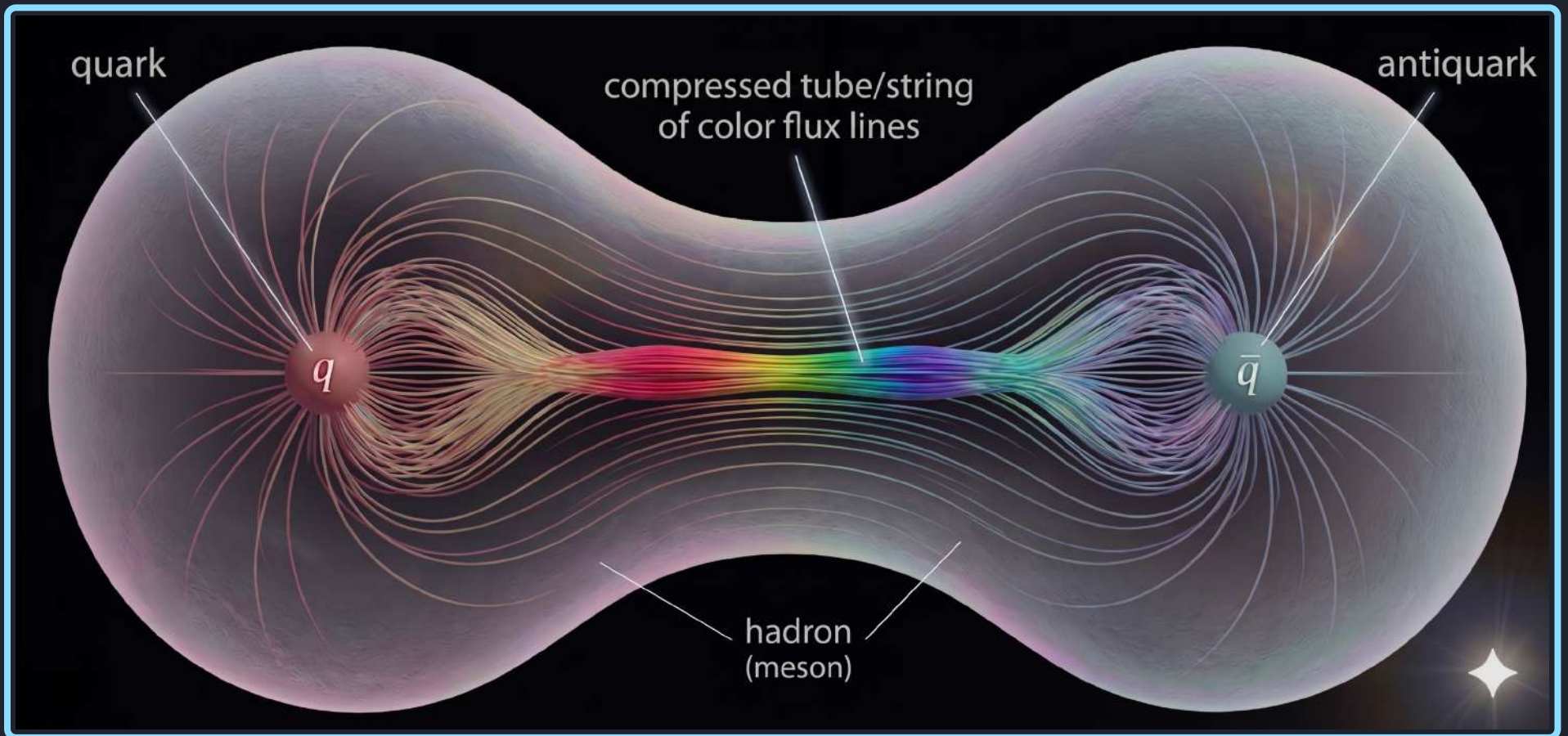

While a proof of quark confinement in hadrons remains wide open, a suggestive *heuristic* picture has solidified over the decades:

There are “color” *flux lines* between quarks, compressed by a condensate of *magnetic monopoles* to a *flux tube/string*, which binds them together.

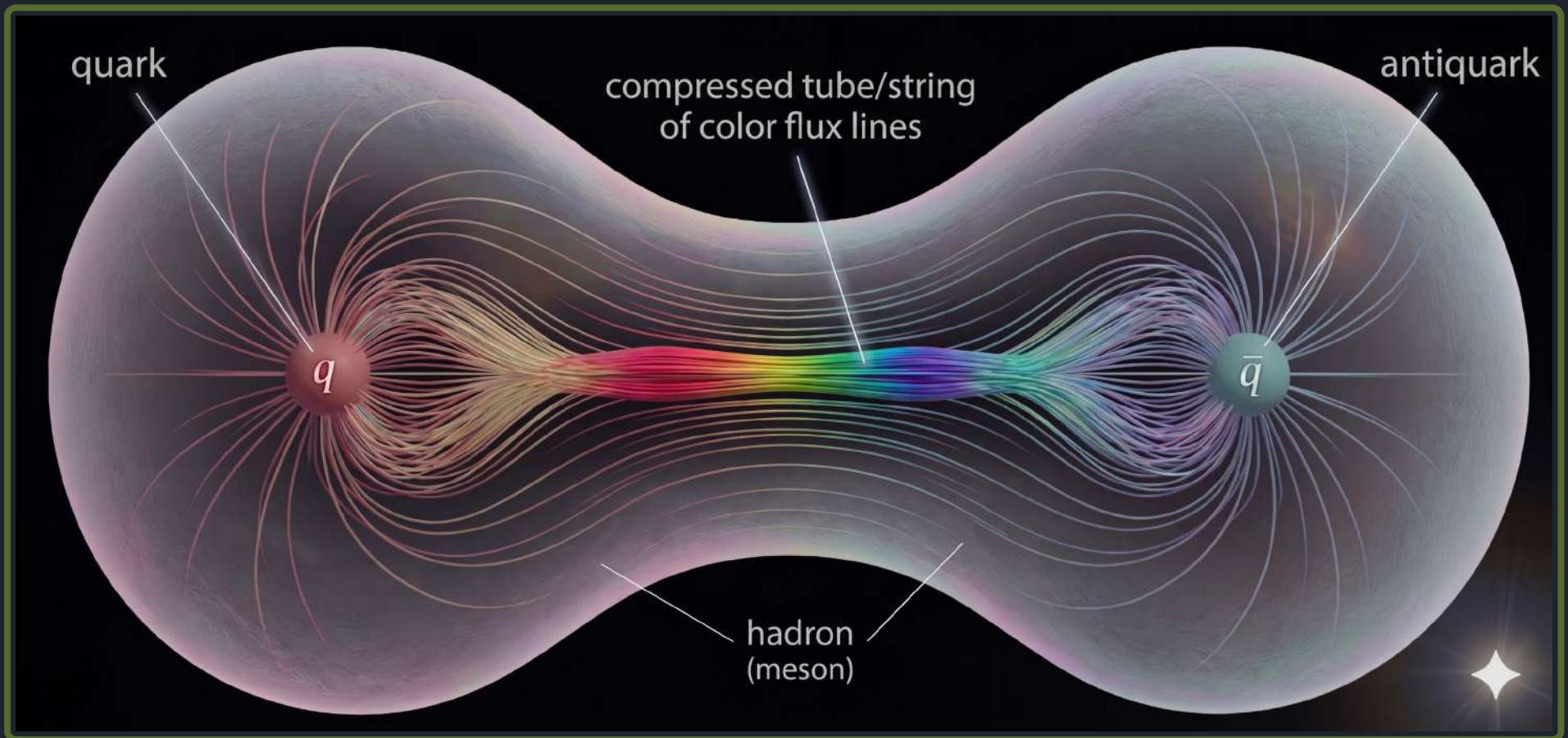

While a proof of quark confinement in hadrons remains wide open, a suggestive *heuristic* picture has solidified over the decades:

There are “color” *flux lines* between quarks, compressed by a condensate of *magnetic monopoles* to a *flux tube/string*, which binds them together.

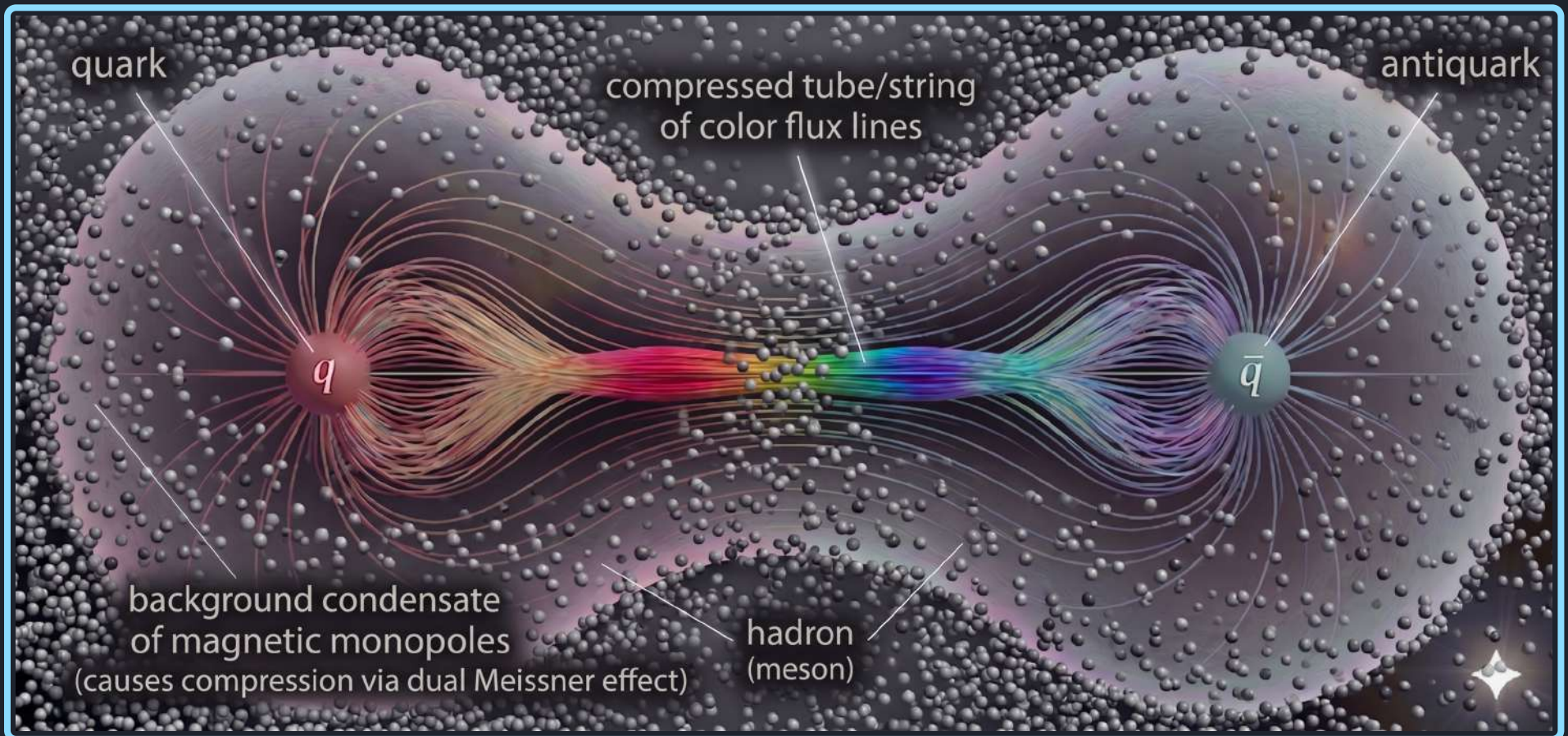

While a proof of quark confinement in hadrons remains wide open, a suggestive *heuristic* picture has solidified over the decades:

There are “color” *flux lines* between quarks, compressed by a condensate of *magnetic monopoles* to a *flux tube/string*, which binds them together.

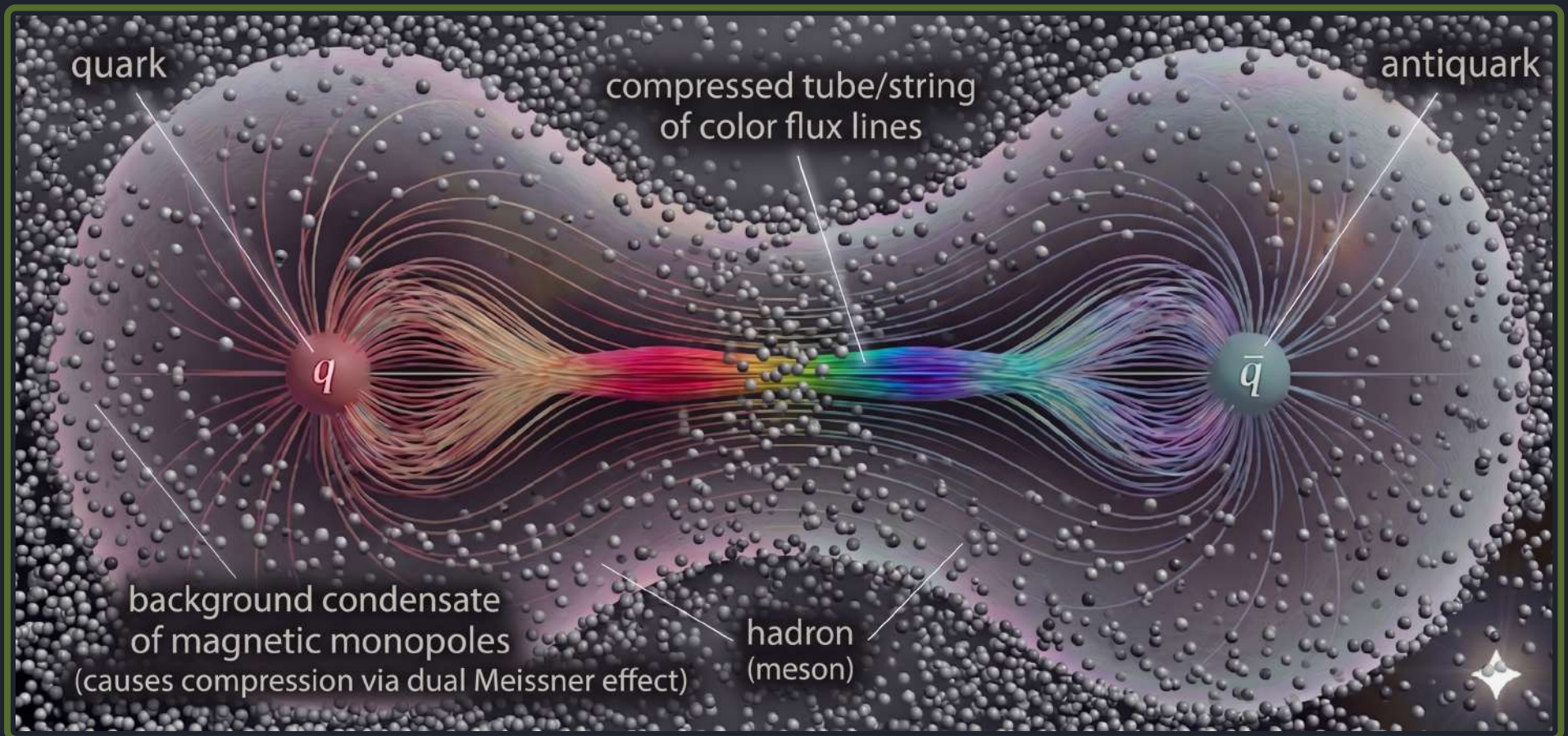

So the question is: How to make this mathematically precise?

While a proof of quark confinement in hadrons remains wide open, a suggestive *heuristic* picture has solidified over the decades:

There are “color” *flux lines* between quarks, compressed by a condensate of *magnetic monopoles* to a *flux tube/string*, which binds them together.

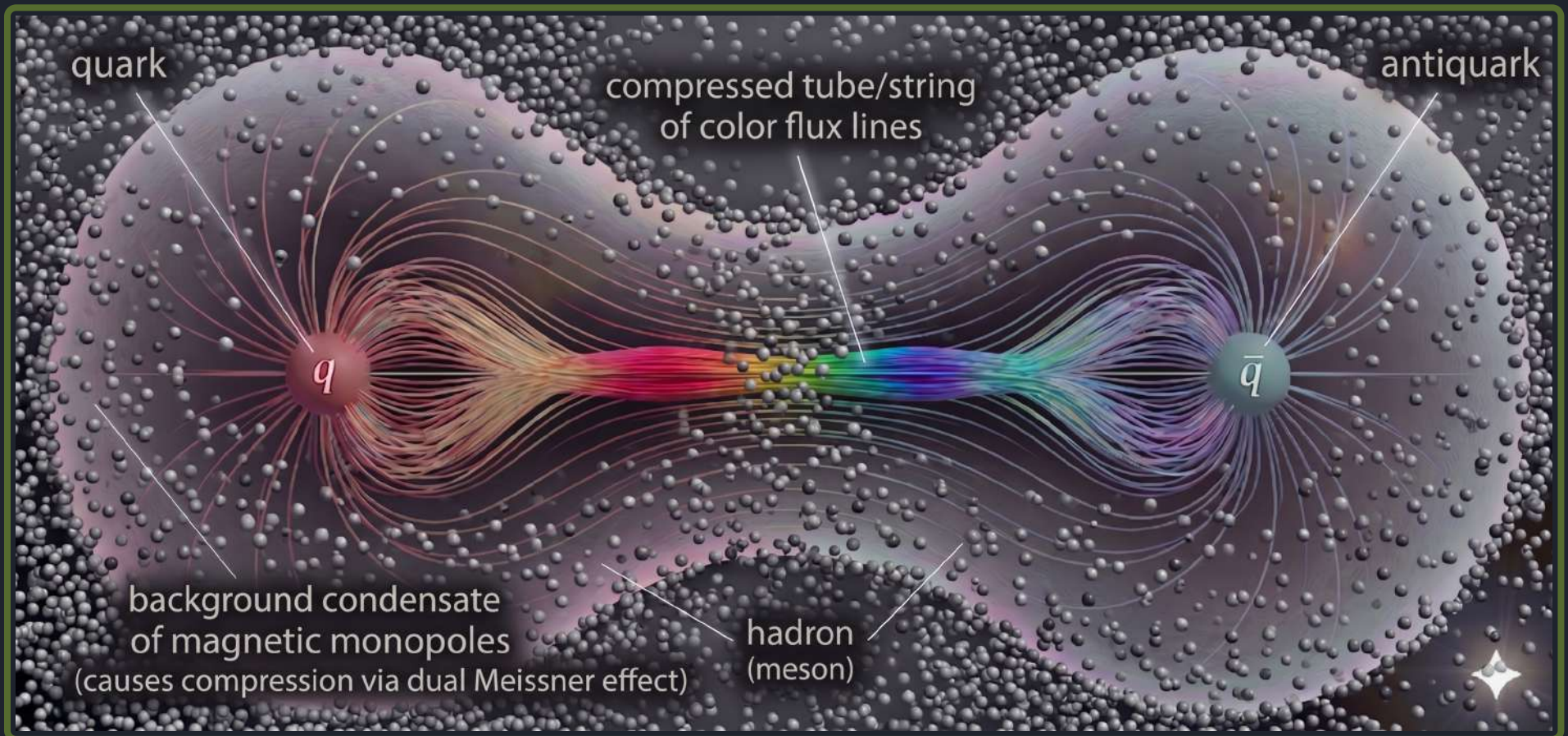

So the question is: How to make this mathematically precise?
We come back to this later. Now first on a related problem...

Analogous issues haunt *condensed matter theory*
where many particles condense to solids or fluids

Analogous issues haunt *condensed matter theory*
where many particles condense to solids or fluids

Here non-perturbative strong interactions
are referred to as *strong correlations*

Analogous issues haunt *condensed matter theory*
where many particles condense to solids or fluids

Here non-perturbative strong interactions
are referred to as *strong correlations*

WEAKLY-COUPLED ELECTRONS
(Independent)

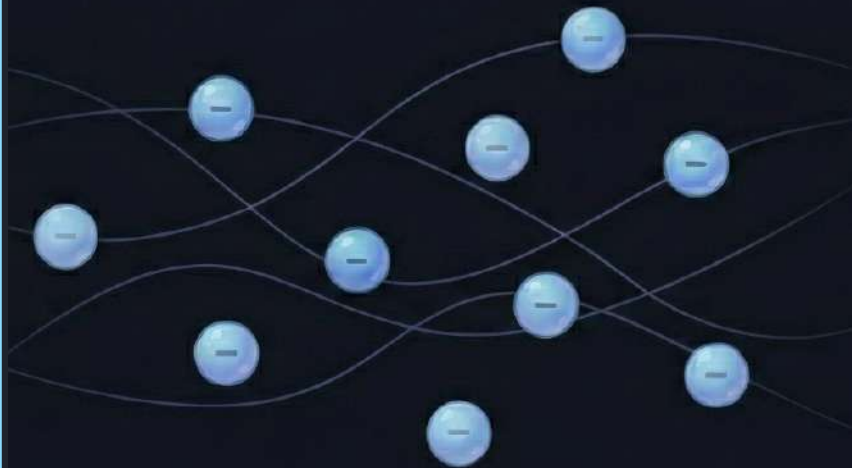

Like individuals in a sparse crowd,
moving freely.

STRONGLY-COUPLED ELECTRONS
(Correlated)

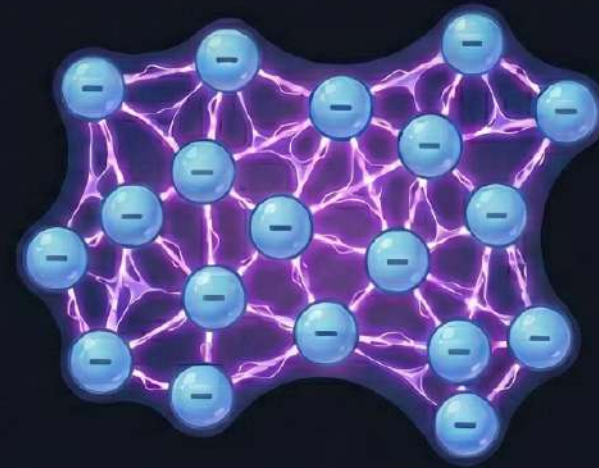

Like a dense mosh pit, movements
are linked and collective.

Analogous issues haunt *condensed matter theory*
where many particles condense to solids or fluids

Here non-perturbative strong interactions
are referred to as *strong correlations*

WEAKLY-COUPLED ELECTRONS
(Independent)

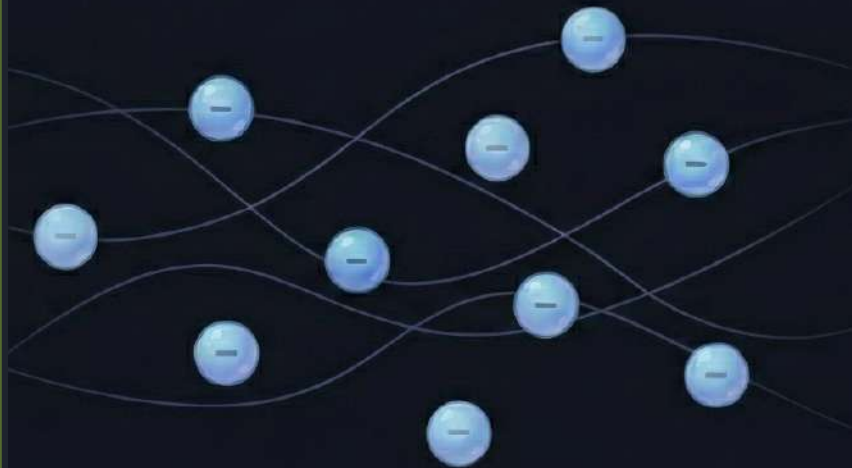

Like individuals in a sparse crowd,
moving freely.

STRONGLY-COUPLED ELECTRONS
(Correlated)

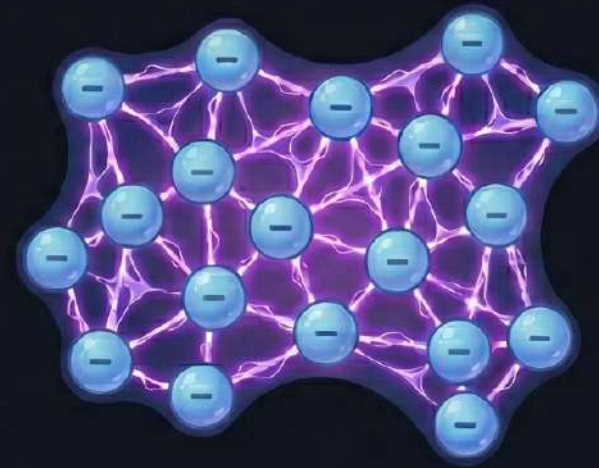

Like a dense mosh pit, movements
are linked and collective.

Strongly-correlated electrons show
remarkable but largely mysterious behaviour

Strongly-correlated electrons show remarkable but largely mysterious behaviour

Quintanilla & Hooley 2009

Feature: Strong correlations

physicsworld.com

The strong-correlations puzzle

A solution to one of the most famous problems in theoretical physics, formulated almost 50 years ago, may at last be within reach. But as **Jorge Quintanilla** and **Chris Hooley** explain, it **relies not on theory,**

Strongly-correlated electrons show remarkable but largely mysterious behaviour

Quintanilla & Hooley 2009

Feature: Strong correlations

physicsworld.com

The strong-correlations puzzle

A solution to one of the most famous problems in theoretical physics, formulated almost 50 years ago, may at last be within reach. But as **Jorge Quintanilla** and **Chris Hooley** explain, it relies not on theory,

For instance, *Quantum Hall Systems*

For instance, *Quantum Hall Systems* are
2D electron liquids in a transverse magnetic field

For instance, *Quantum Hall Systems* are 2D electron liquids in a transverse magnetic field

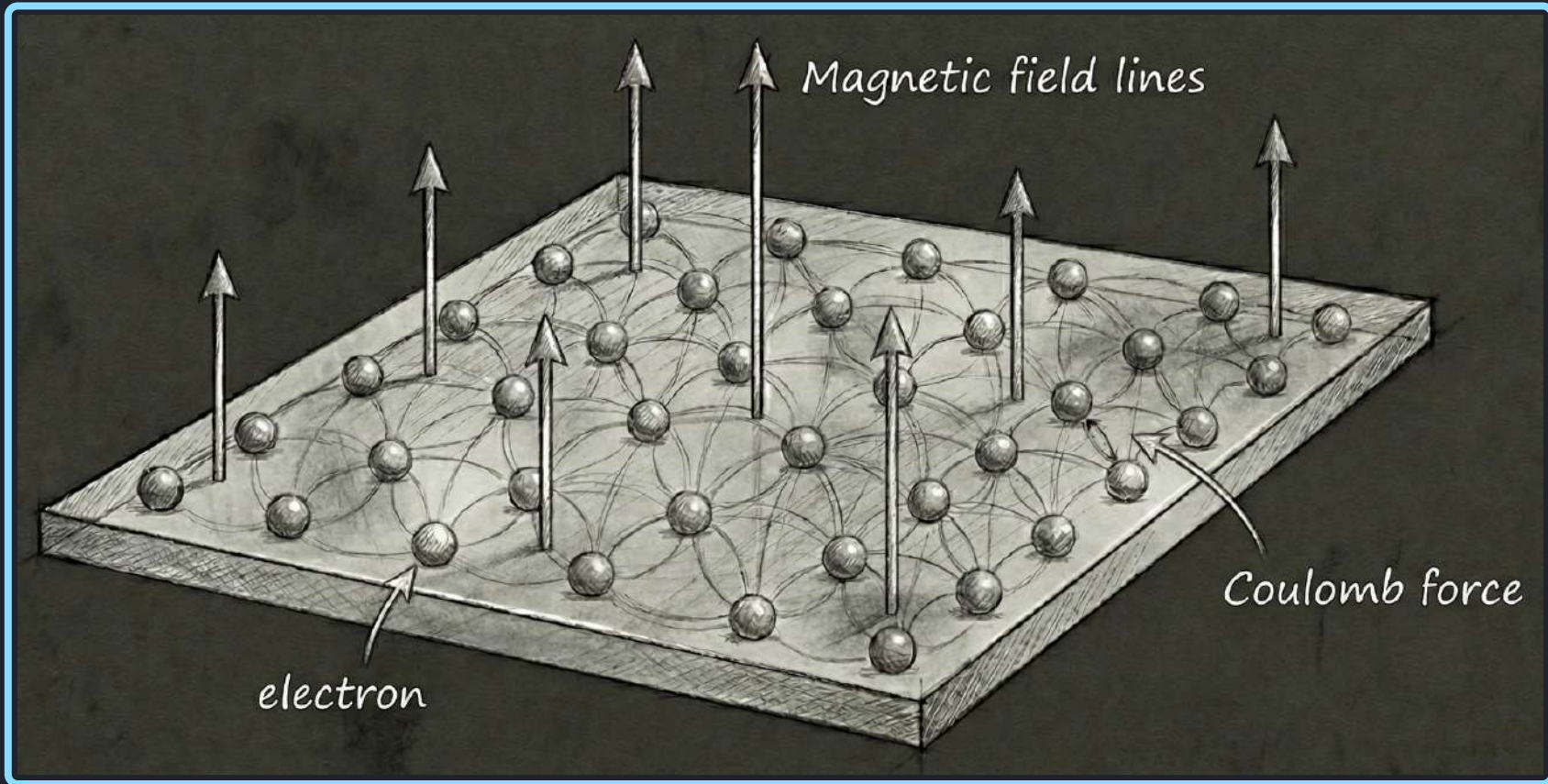

For instance, *Quantum Hall Systems* are 2D electron liquids in a transverse magnetic field

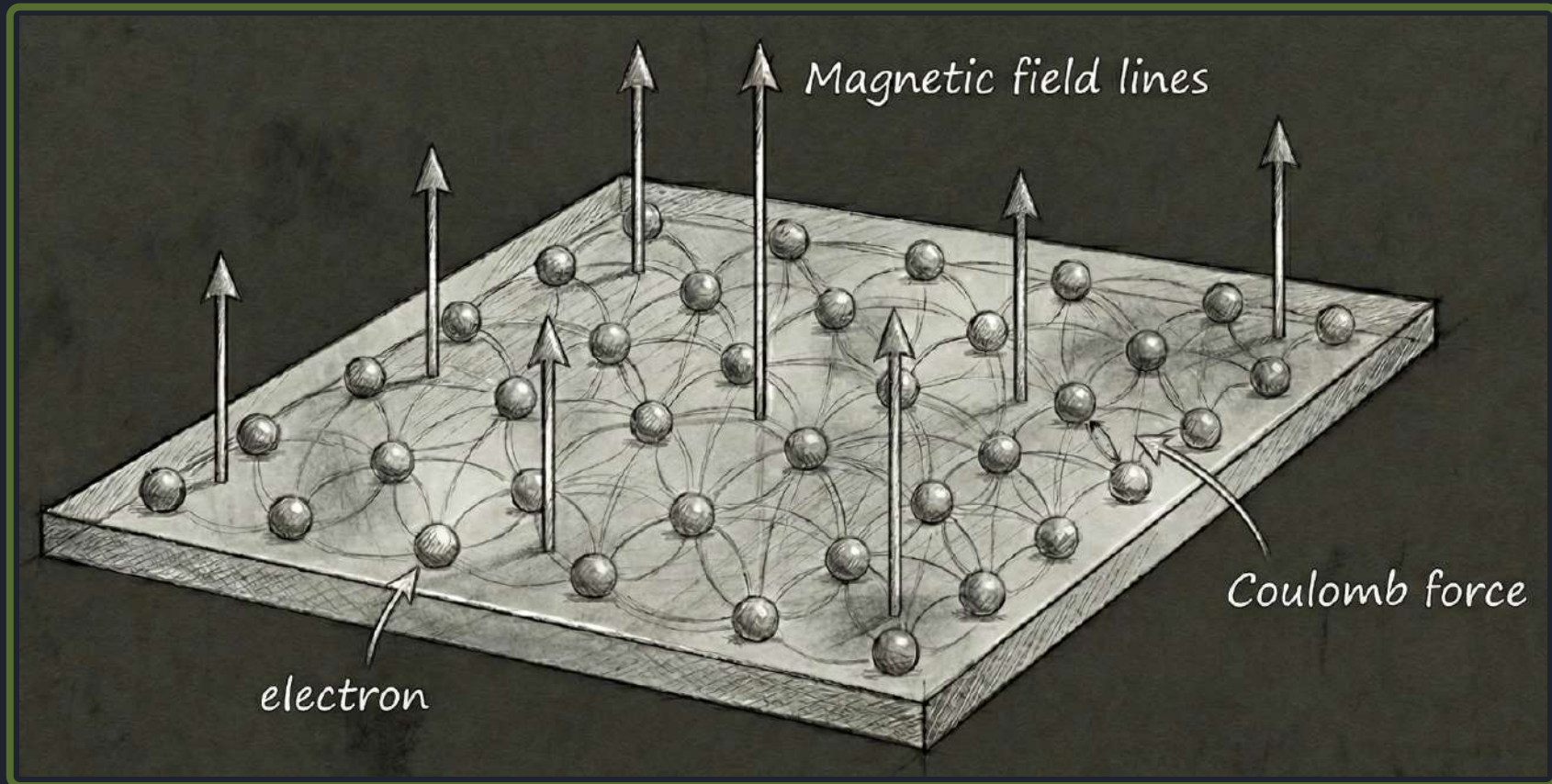

Something remarkable happens when there are exactly k magnetic field lines per electron

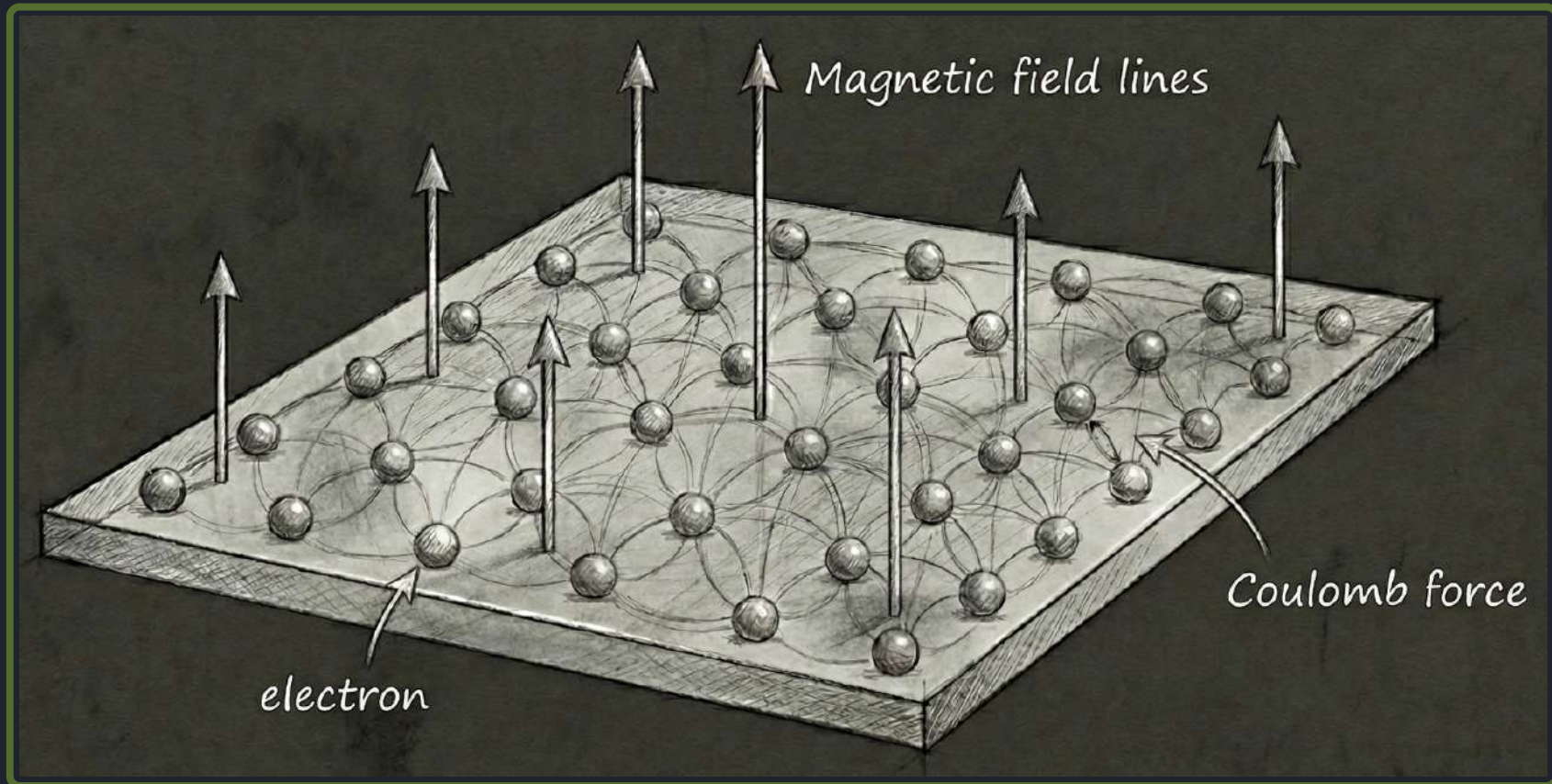

Something remarkable happens when there are exactly k magnetic field lines per electron

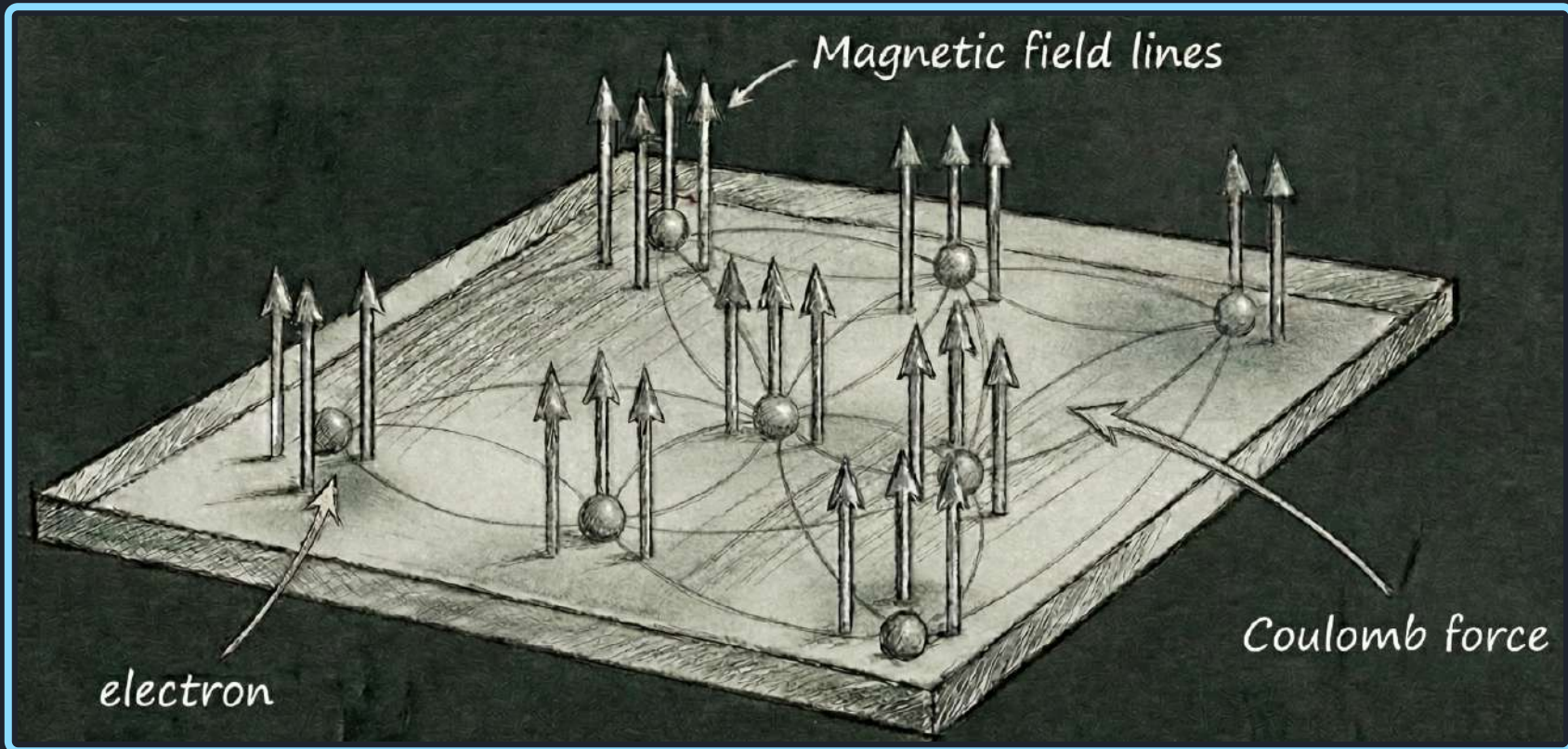

Something remarkable happens when there are exactly k magnetic field lines per electron

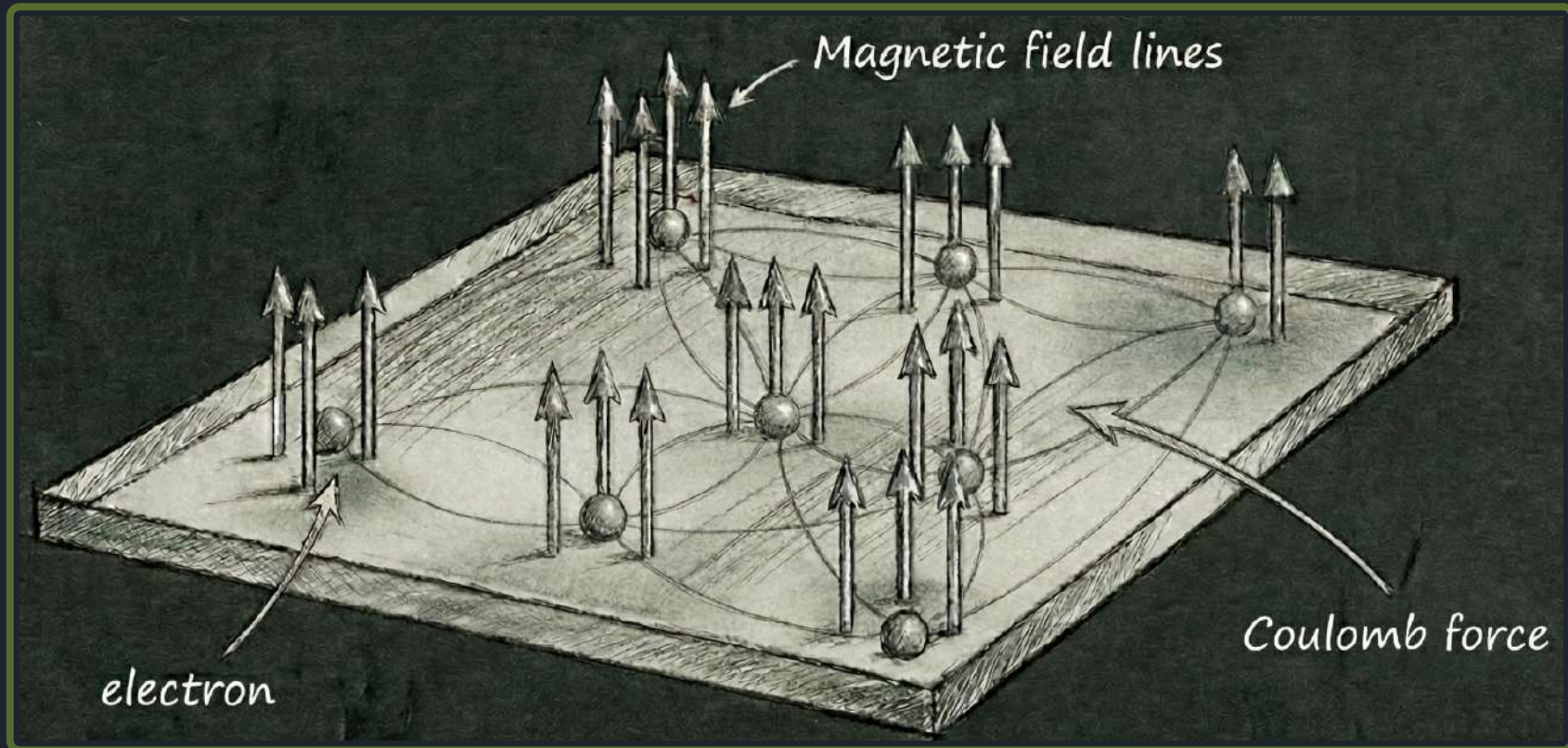

Called *Fractional Quantum Hall* (FQH)
liquids at *filling fraction* $\nu = 1/k$

Something remarkable happens when there are exactly k magnetic field lines per electron

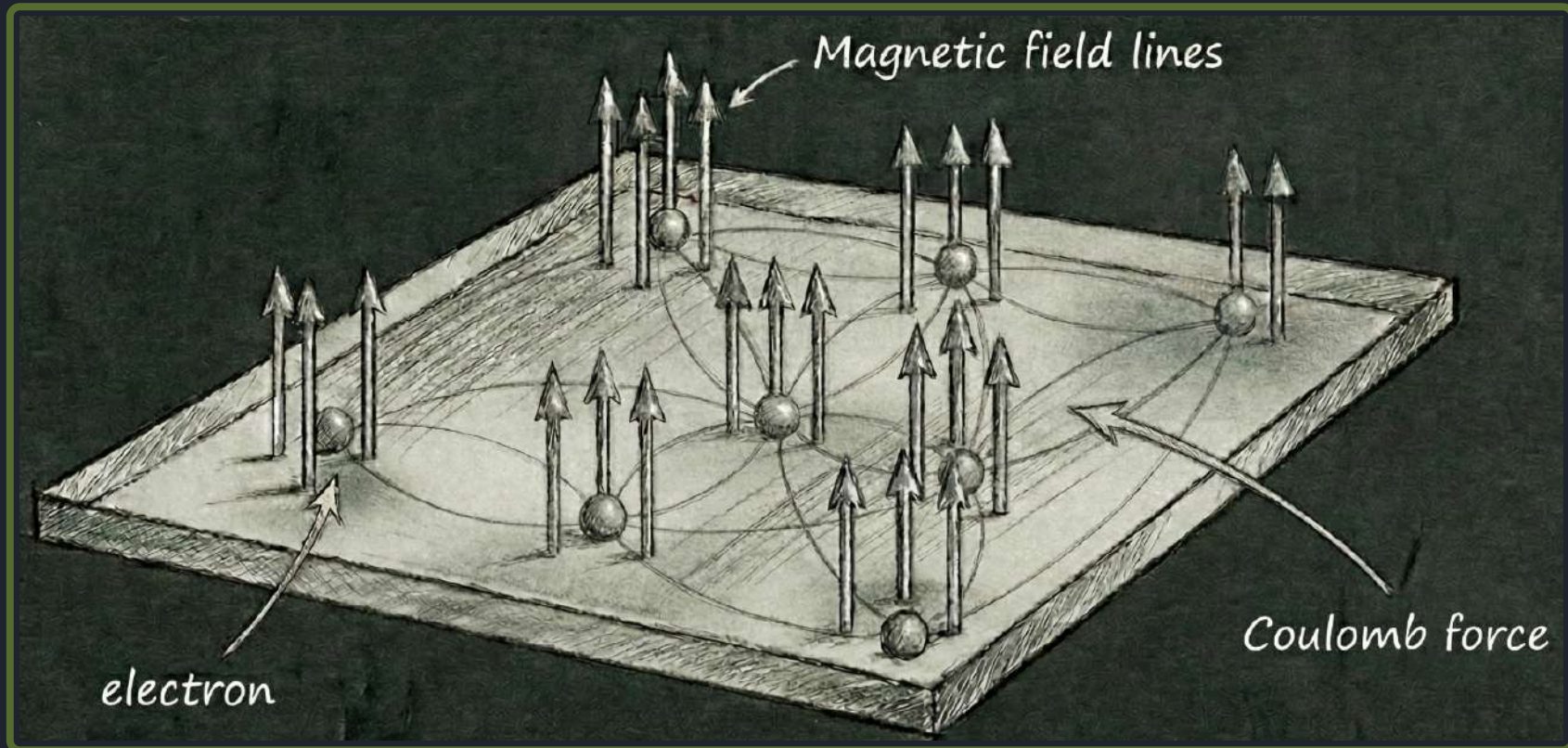

Called *Fractional Quantum Hall* (FQH)
liquids at *filling fraction* $\nu = 1/k$

On such a backdrop, every surplus magnetic line
is like the lack of $1/k$ th of an electron

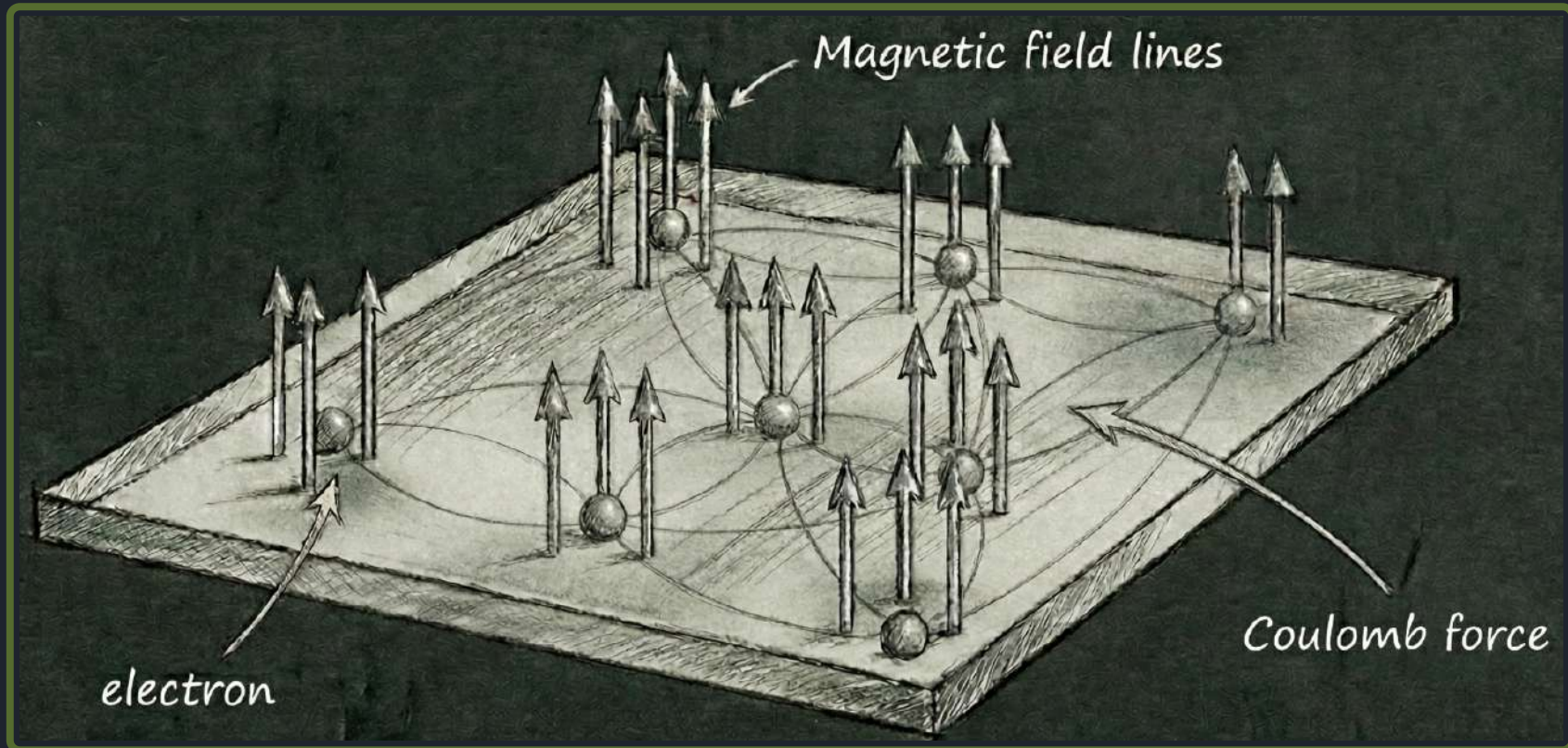

On such a backdrop, every surplus magnetic line
is like the lack of $1/k$ th of an electron

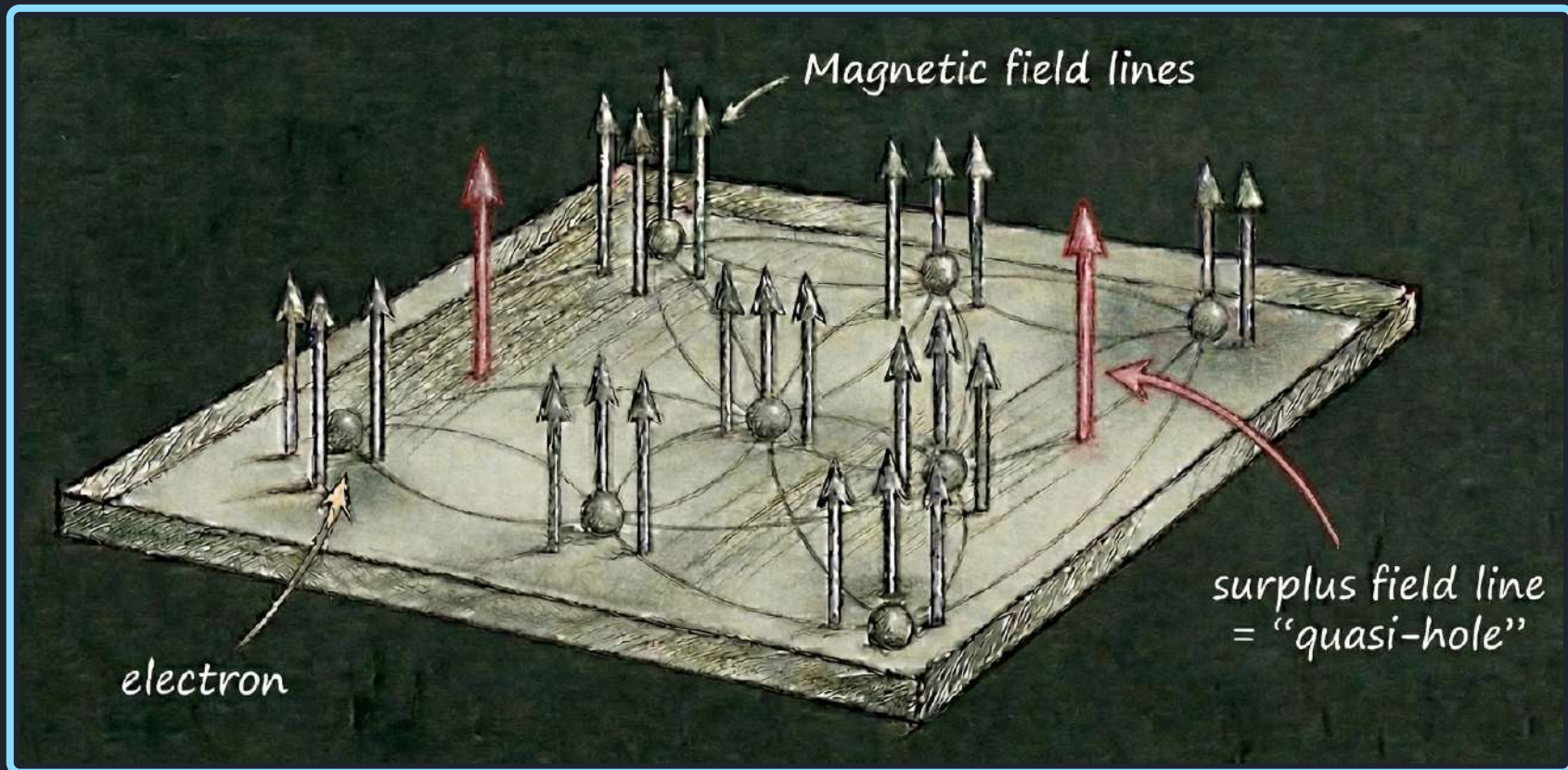

On such a backdrop, every surplus magnetic line
is like the lack of $1/k$ th of an electron

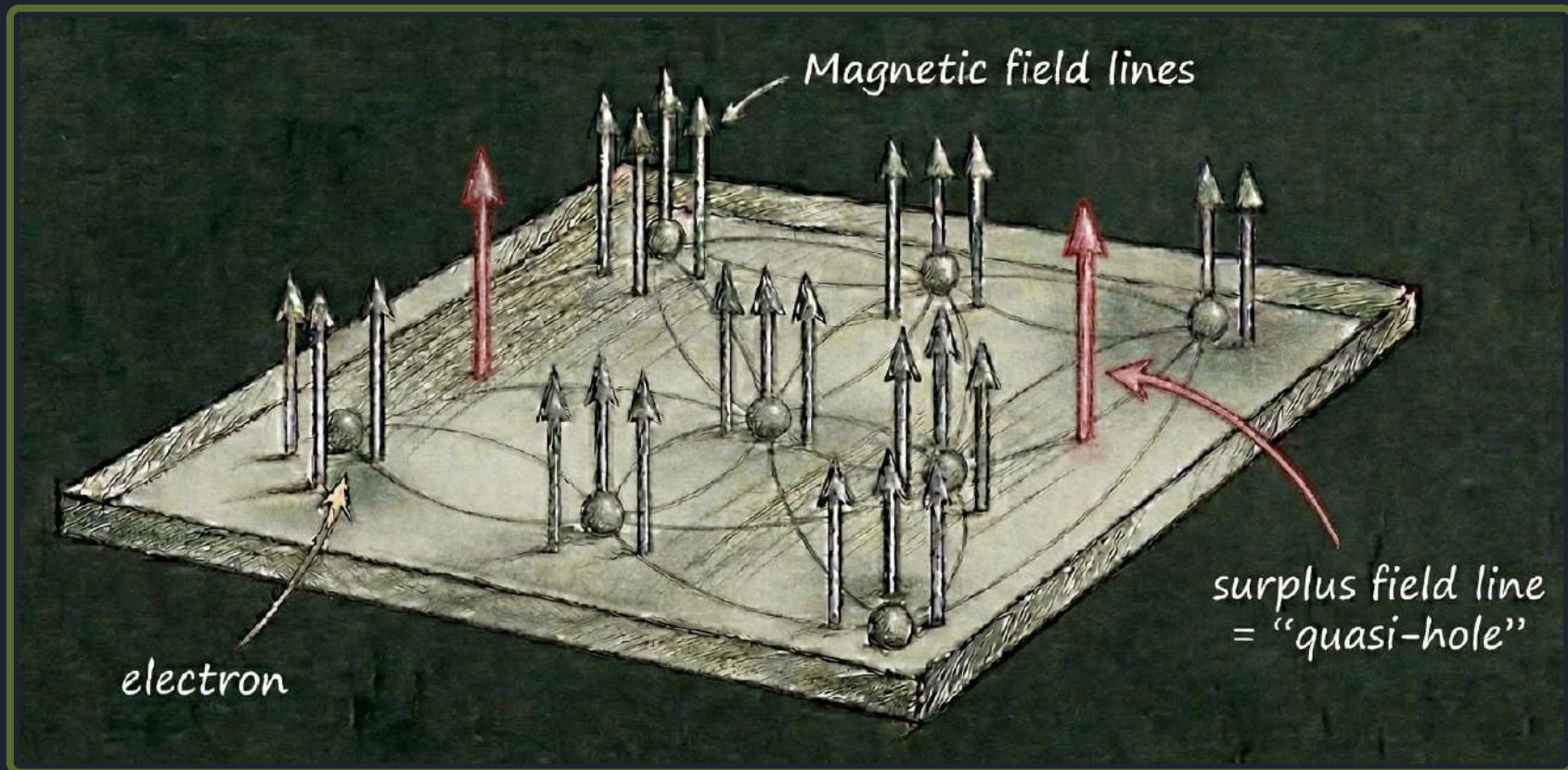

these *quasi-holes* appear like
fractional quasi-particles in the FQH liquid.

On such a backdrop, every surplus magnetic line
is like the lack of $1/k$ th of an electron

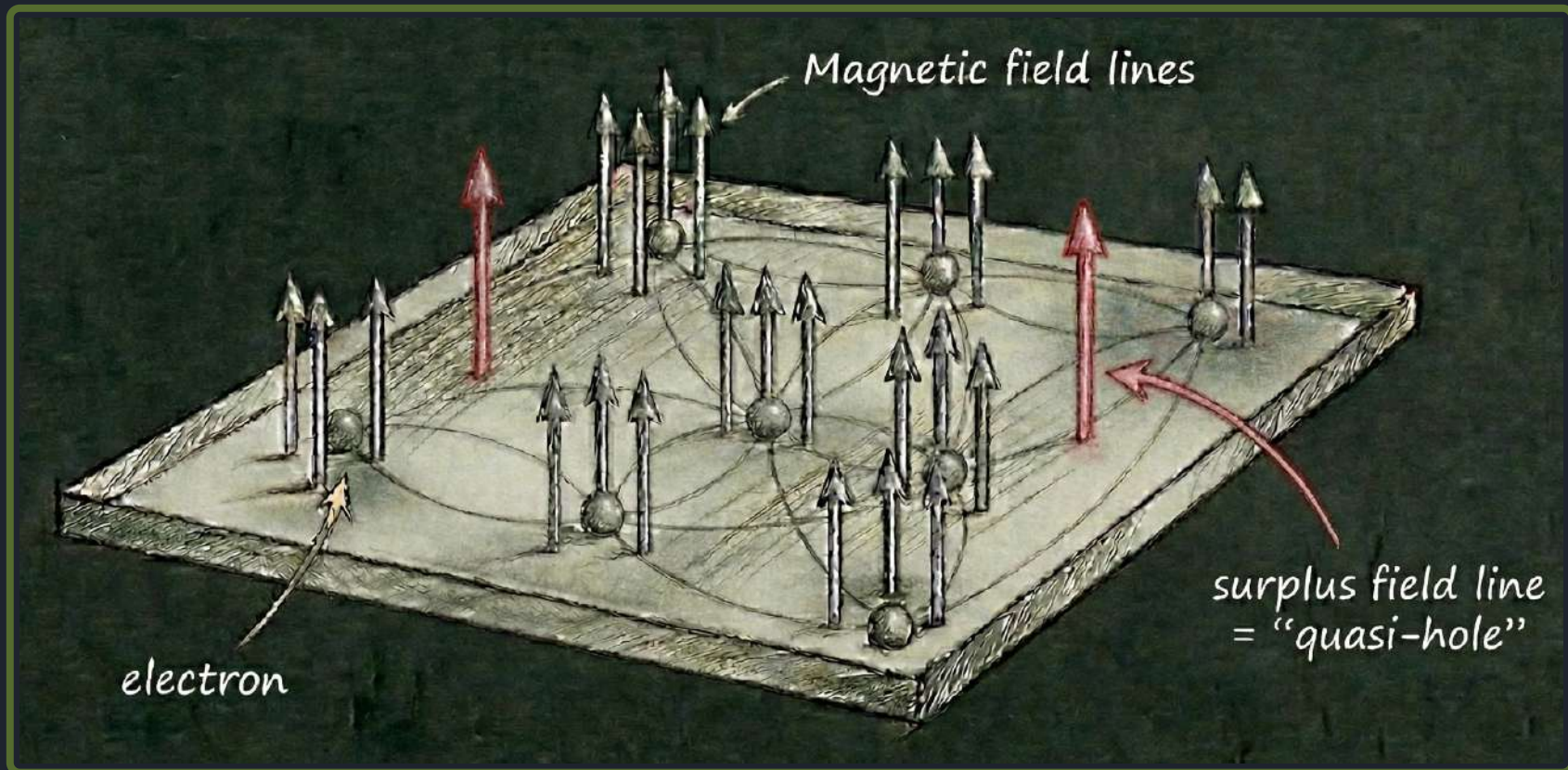

these *quasi-holes* appear like
fractional quasi-particles in the FQH liquid.

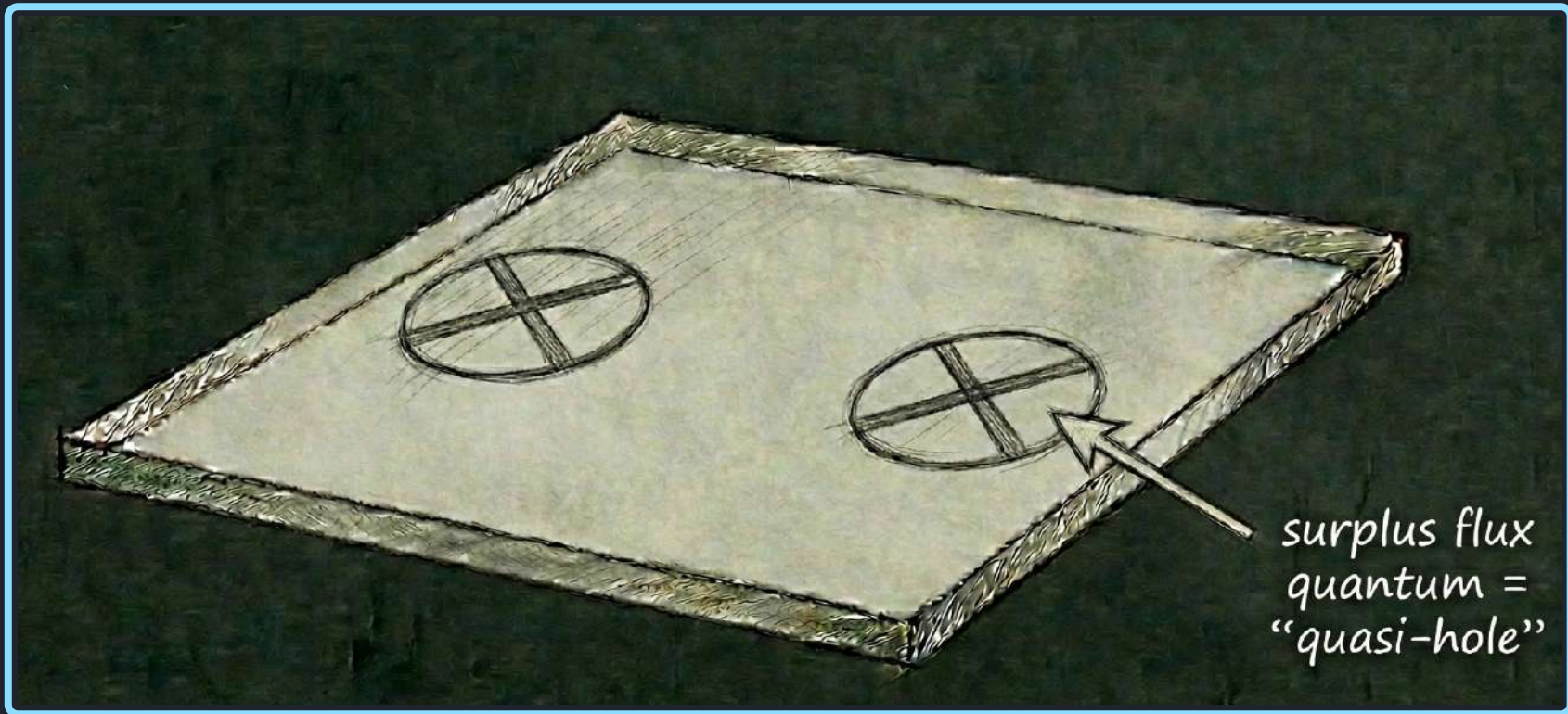

these *quasi-holes* appear like fractional quasi-particles in the FQH liquid.

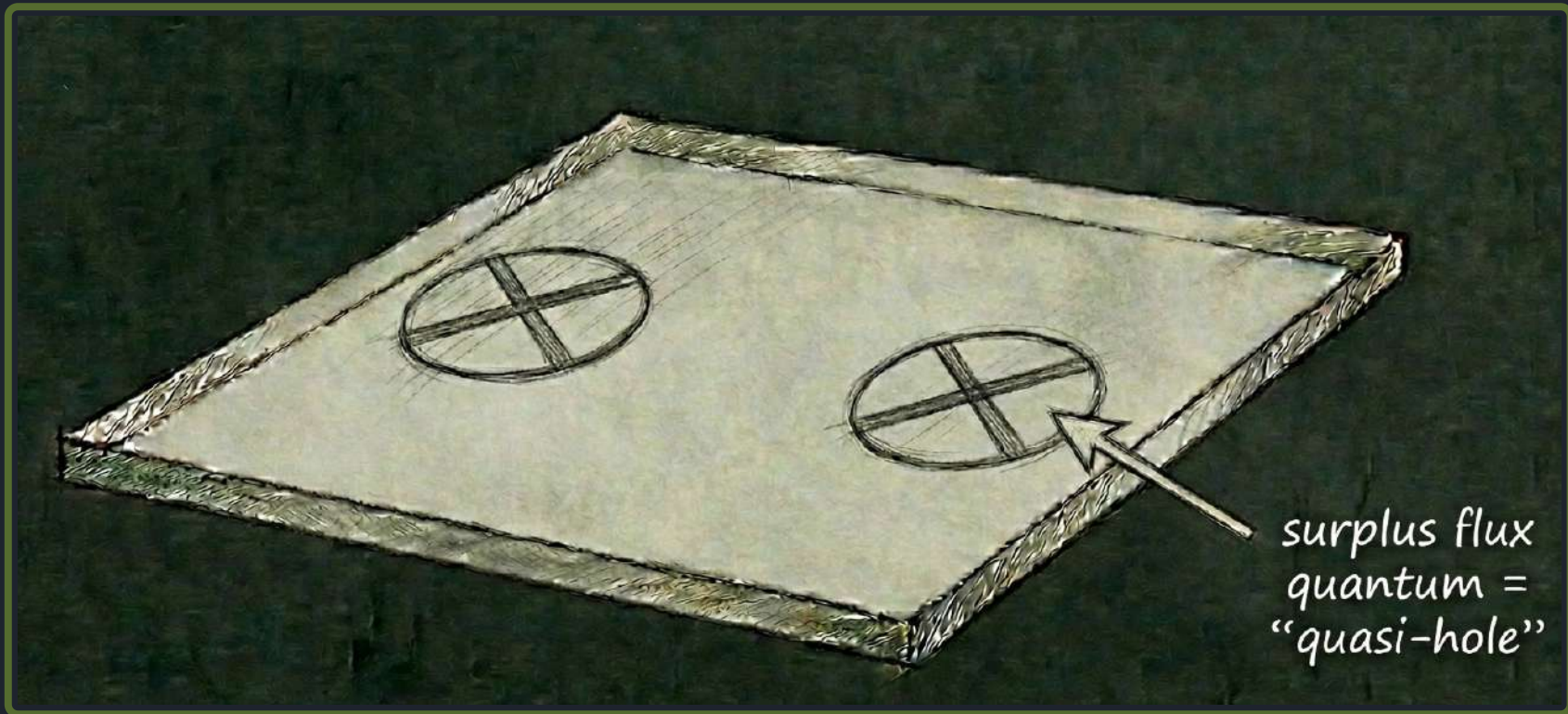

these *quasi-holes* appear like fractional quasi-particles in the FQH liquid.

These have the most remarkable property
that the *braiding* of their worldlines...

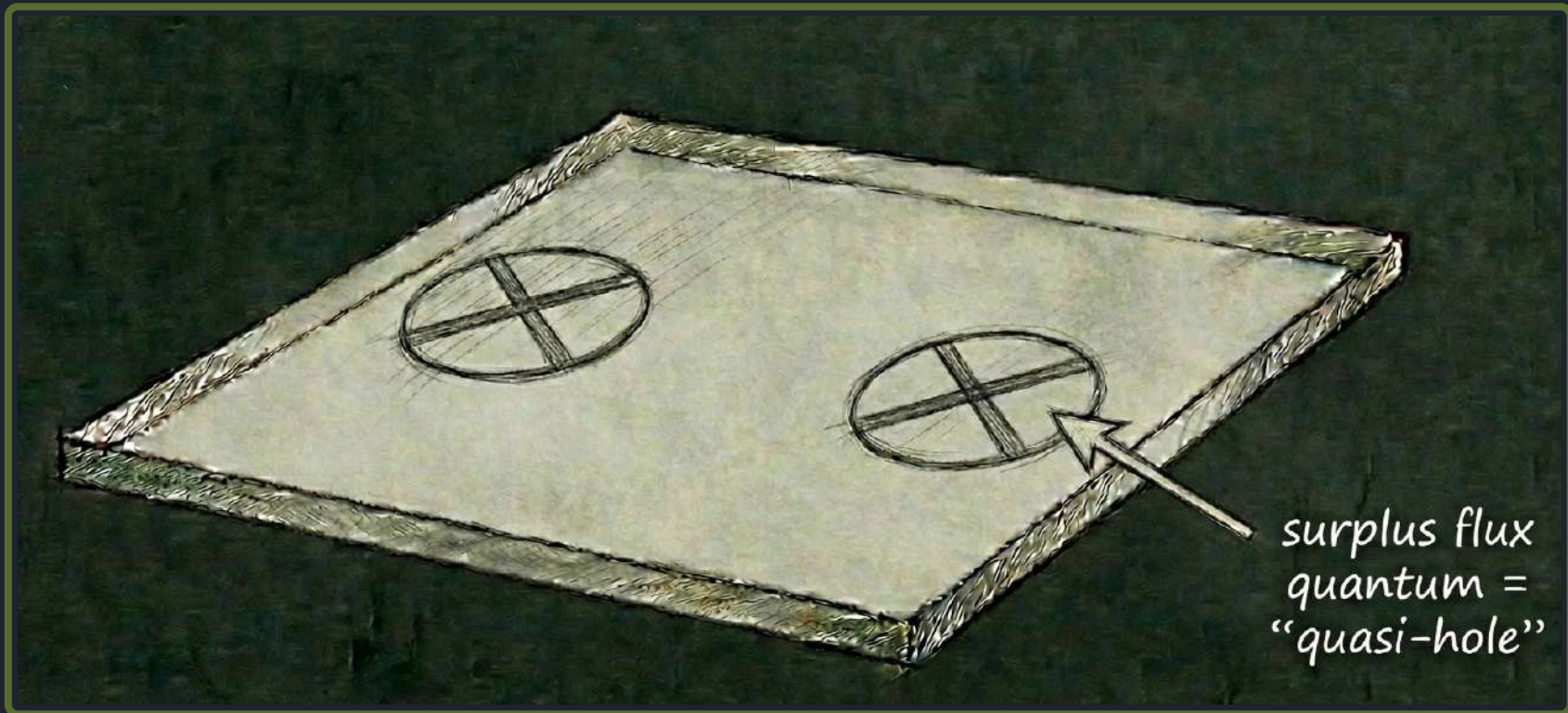

These have the most remarkable property
that the *braiding* of their worldlines...

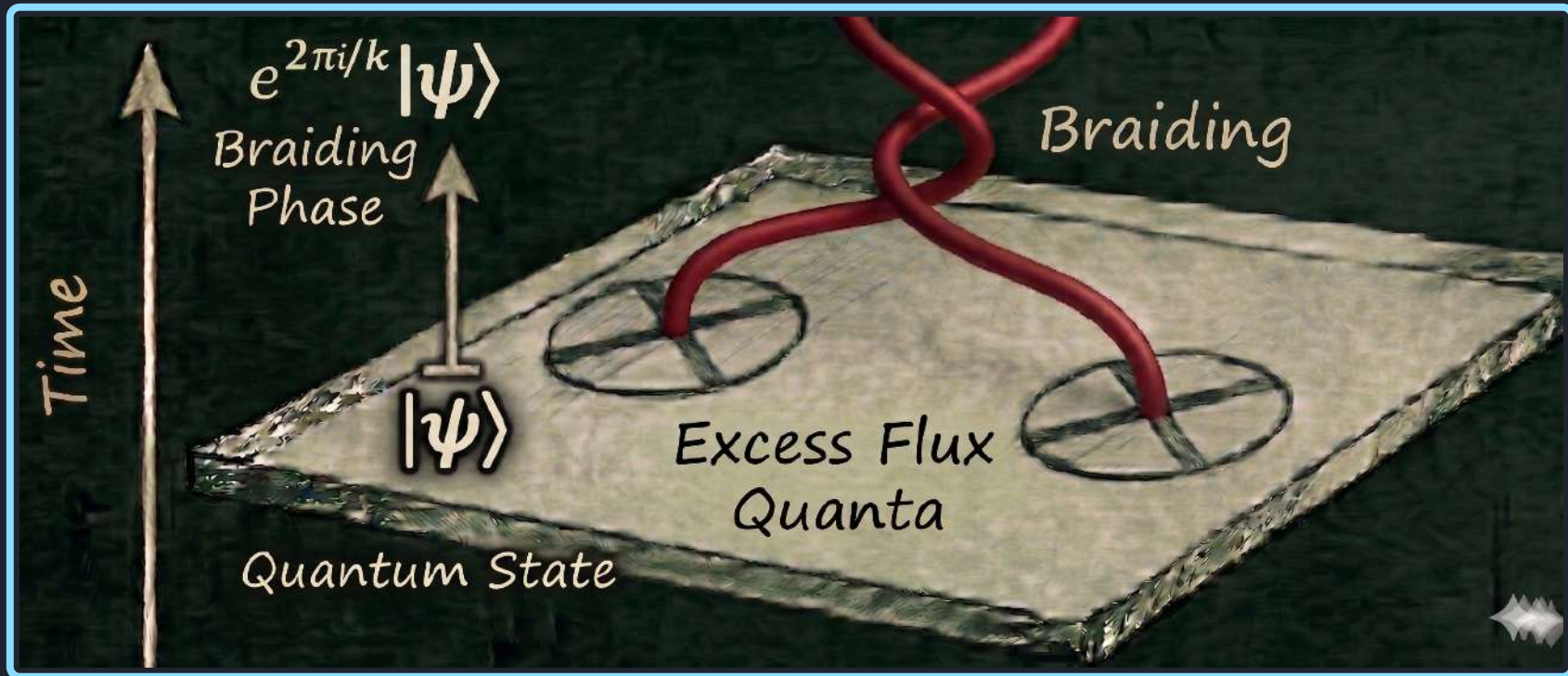

These have the most remarkable property
that the *braiding* of their worldlines...

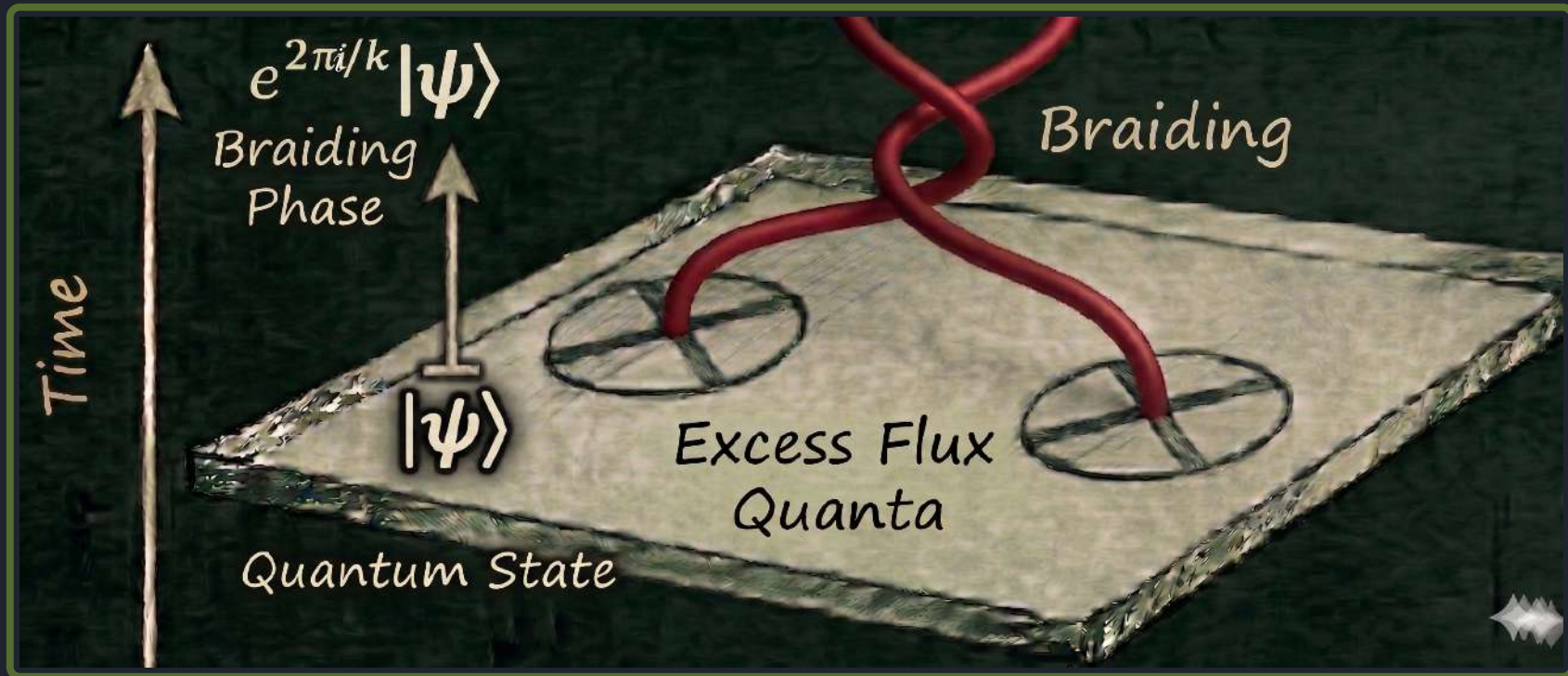

... causes the quantum state to change by a phase,

These have the most remarkable property
that the *braiding* of their worldlines...

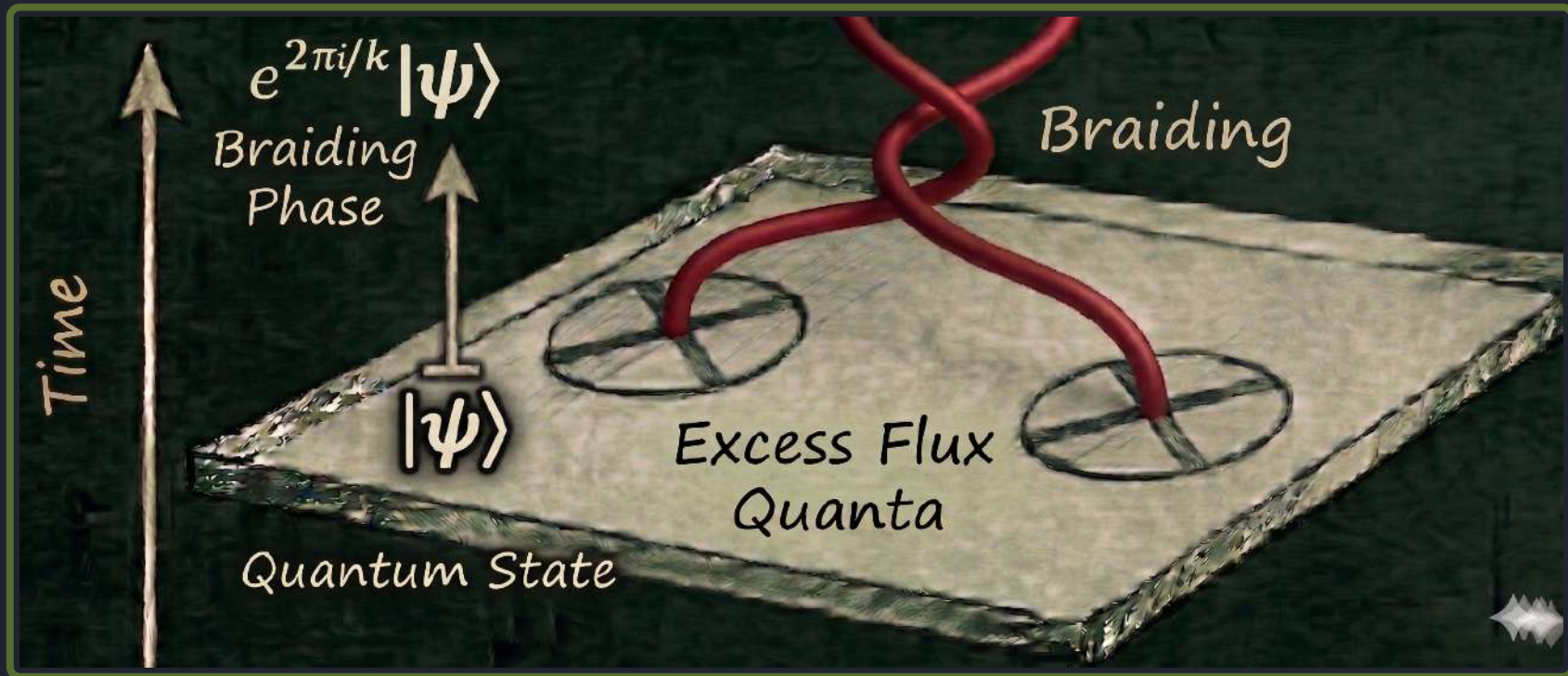

... causes the quantum state to change by a phase,
which depends only on the braiding/knotting

These have the most remarkable property
that the *braiding* of their worldlines...

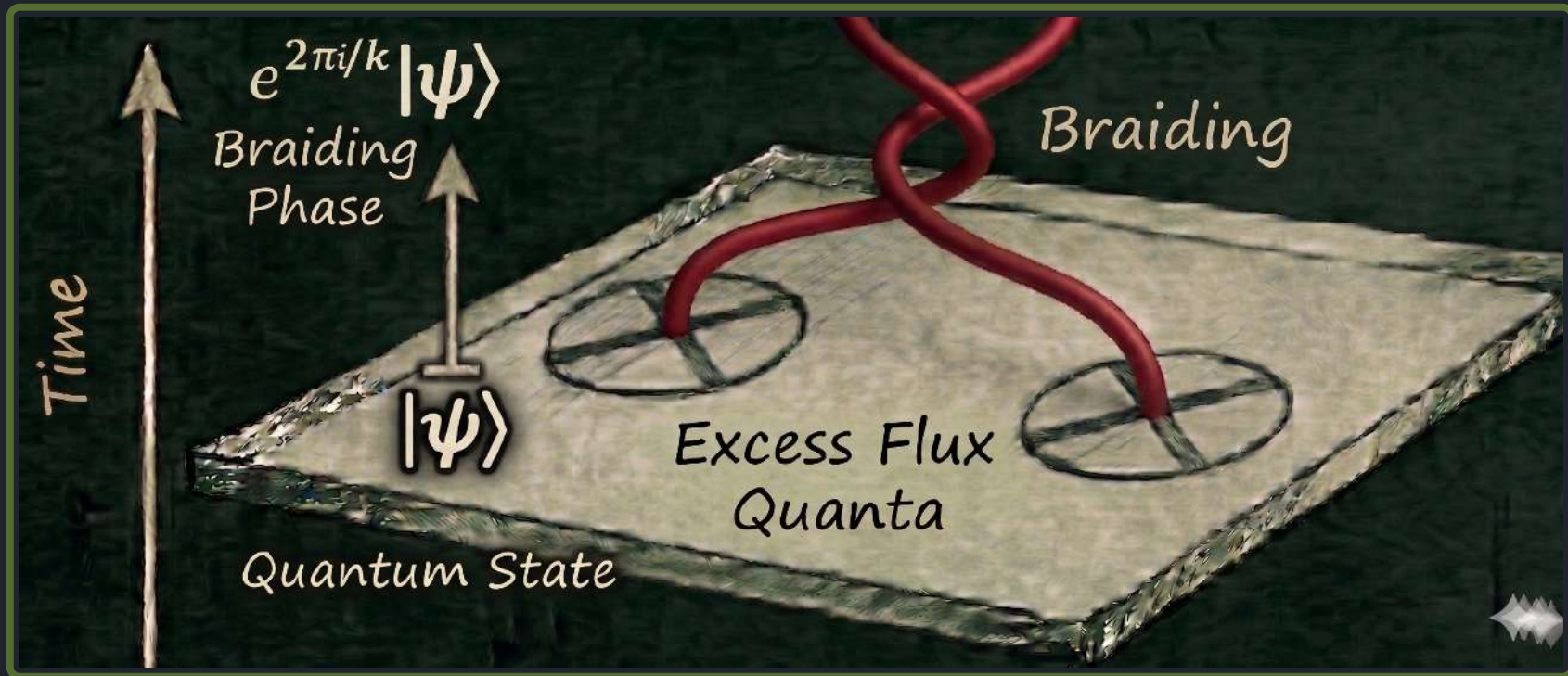

... causes the quantum state to change by a phase,
which depends only on the braiding/knotting

These processes may serve as
topological quantum gates

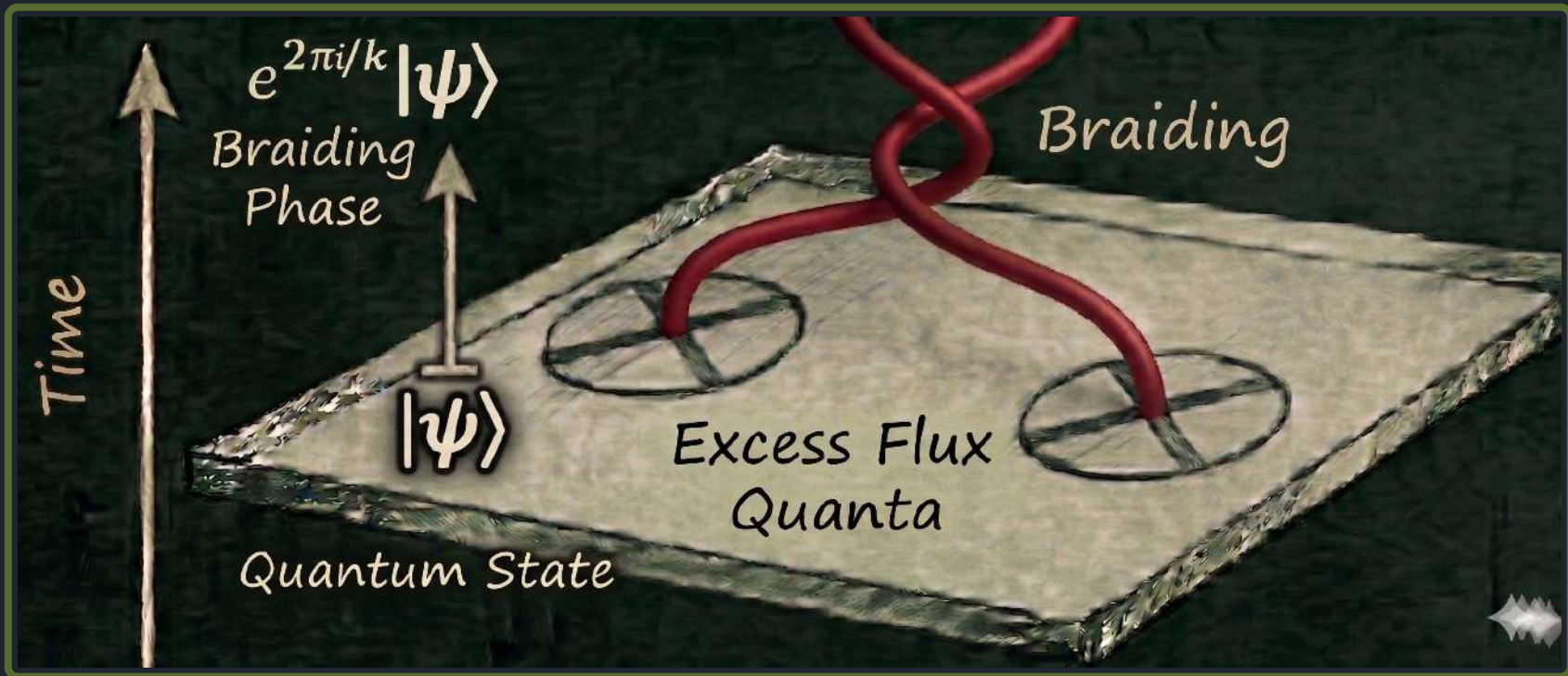

These processes may serve as
topological quantum gates

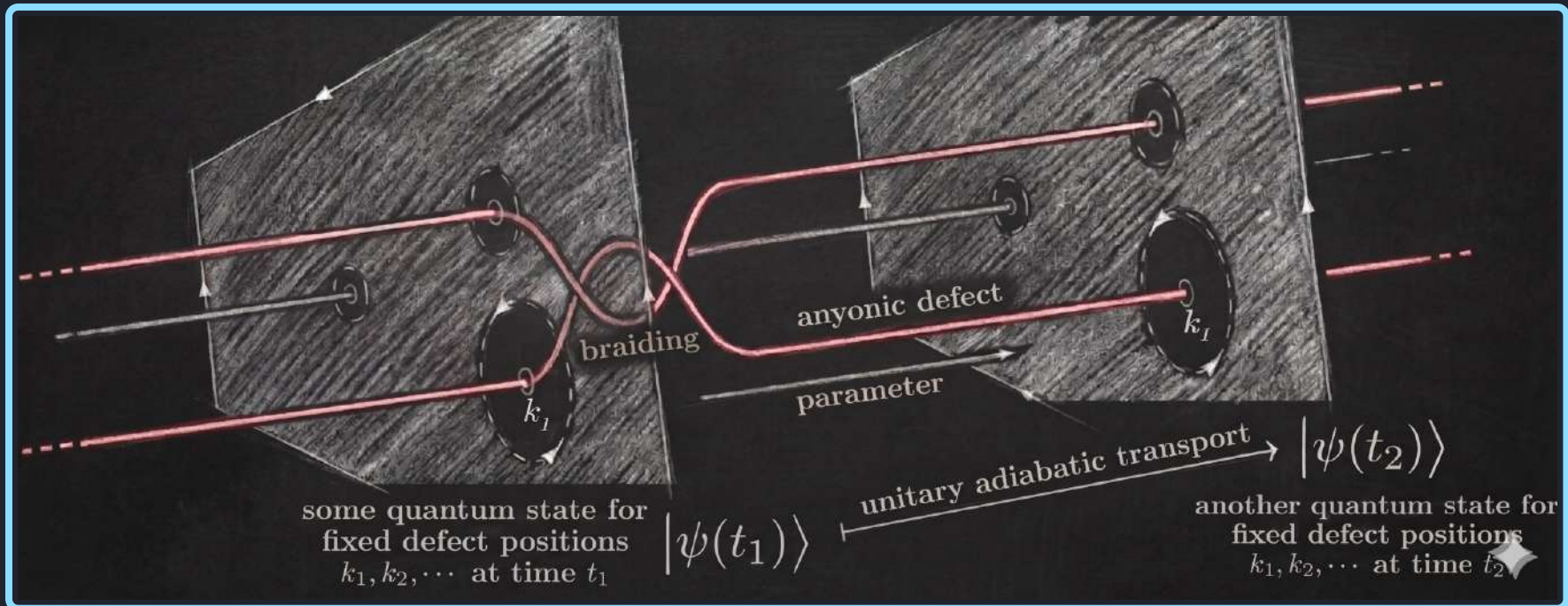

These processes may serve as
topological quantum gates

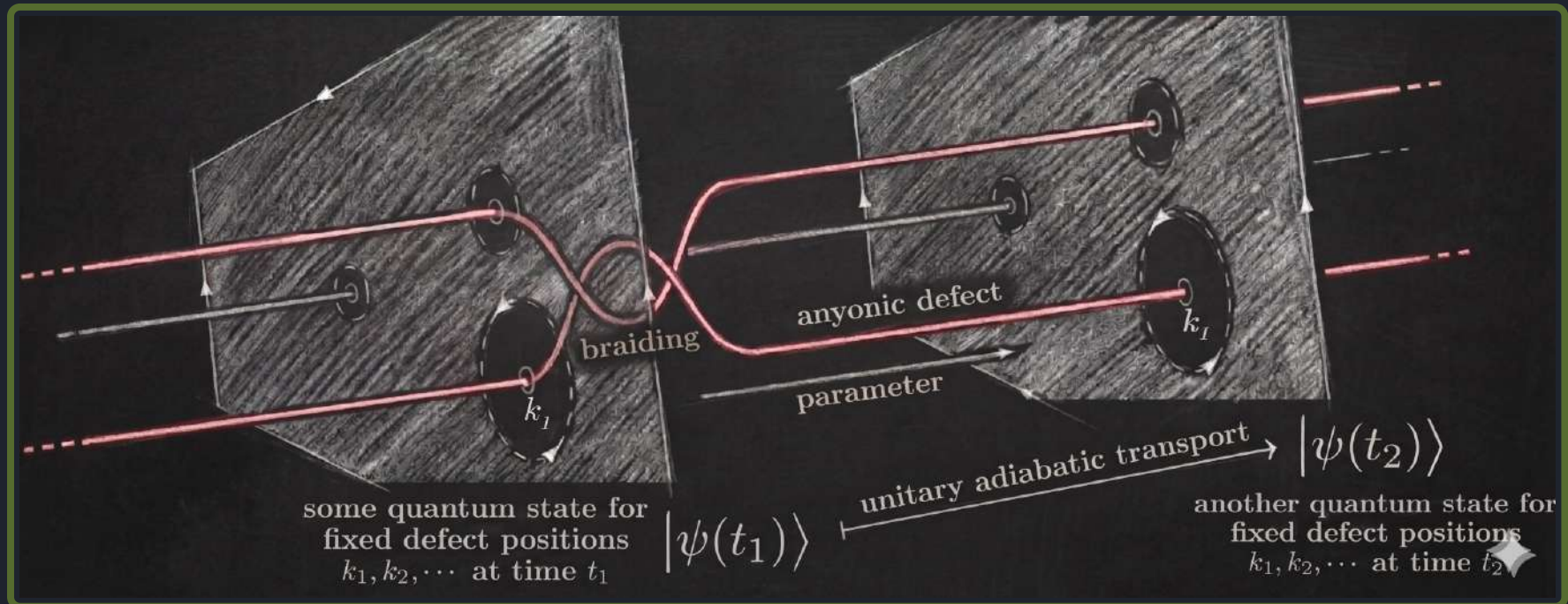

but let's first step back and talk about quantum computing

These processes may serve as
topological quantum gates

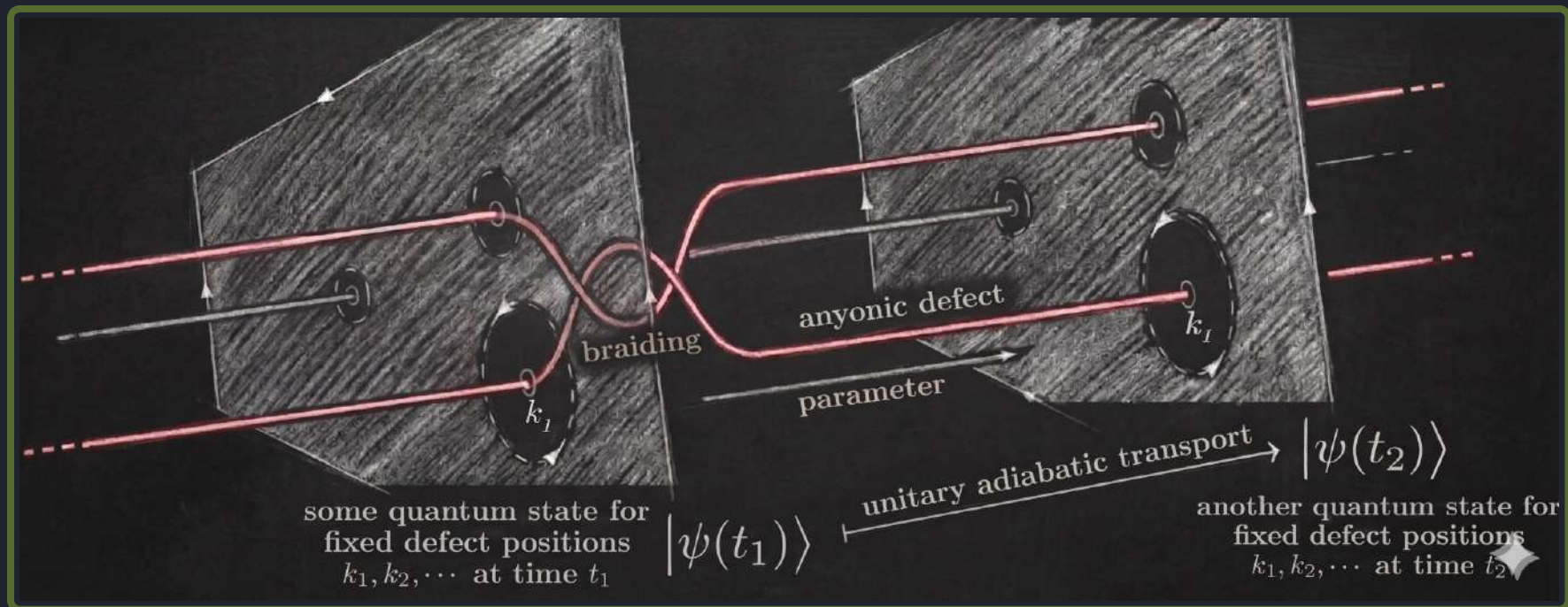

but let's first step back and talk about quantum computing

Crash Course on Quantum Computing

Crash Course on Quantum Computing

quantum state: probabilistic state of
nanoscopic matter $|\psi\rangle \in \mathcal{H}$

Crash Course on Quantum Computing

quantum state: probabilistic state of nanoscopic matter $|\psi\rangle \in \mathcal{H}$

quantum gate: controlled transformation of quantum states $\mathcal{H} \xrightarrow{U} \mathcal{H}'$
 $|\psi\rangle \mapsto |\psi'\rangle$

Crash Course on Quantum Computing

quantum state: probabilistic state of nanoscopic matter $|\psi\rangle \in \mathcal{H}$

quantum gate: controlled transformation of quantum states $\mathcal{H} \xrightarrow{U} \mathcal{H}'$
 $|\psi\rangle \mapsto |\psi'\rangle$

quantum circuit: algorithmic combination of quantum gates $\mathcal{H}_1 \longrightarrow \mathcal{H}_2$
 $\mathcal{H}_3 \cdots \cdots \cdots \longrightarrow$

Crash Course on Quantum Computing

quantum state: probabilistic state of nanoscopic matter $|\psi\rangle \in \mathcal{H}$

quantum gate: controlled transformation of quantum states $\mathcal{H} \xrightarrow{U} \mathcal{H}'$
 $|\psi\rangle \mapsto |\psi'\rangle$

quantum circuit: algorithmic combination of quantum gates $\left. \begin{array}{c} \mathcal{H}_1 \longrightarrow \mathcal{H}_2 \\ \mathcal{H}_3 \cdots \cdots \cdots \end{array} \right\}$

quantum compute: quantum circuits whose output is some computation $|x\rangle \mapsto |f(x)\rangle$

Crash Course on Quantum Computing

quantum state: probabilistic state of nanoscopic matter $|\psi\rangle \in \mathcal{H}$

quantum gate: controlled transformation of quantum states $\mathcal{H} \xrightarrow{U} \mathcal{H}'$
 $|\psi\rangle \mapsto |\psi'\rangle$

quantum circuit: algorithmic combination of quantum gates $\mathcal{H}_1 \longrightarrow \mathcal{H}_2$
 $\mathcal{H}_3 \cdots \cdots \cdots \longrightarrow$

quantum compute: quantum circuits whose output is some computation $|x\rangle \mapsto |f(x)\rangle$

For certain tasks, quantum computers could be vastly more powerful than classical computers

Crash Course on Quantum Computing

quantum state: probabilistic state of nanoscopic matter $|\psi\rangle \in \mathcal{H}$

quantum gate: controlled transformation of quantum states $\mathcal{H} \xrightarrow{U} \mathcal{H}'$
 $|\psi\rangle \mapsto |\psi'\rangle$

quantum circuit: algorithmic combination of quantum gates $\left. \begin{array}{c} \mathcal{H}_1 \longrightarrow \mathcal{H}_2 \\ \mathcal{H}_3 \cdots \cdots \cdots \end{array} \right\}$

quantum compute: quantum circuits whose output is some computation $|x\rangle \mapsto |f(x)\rangle$

For certain tasks, quantum computers could be vastly more powerful than classical computers – **in principle**.

The major hurdle for quantum computing is decay of the quantum state (“decoherence”).

The major hurdle for quantum computing is decay of the quantum state (“decoherence”).

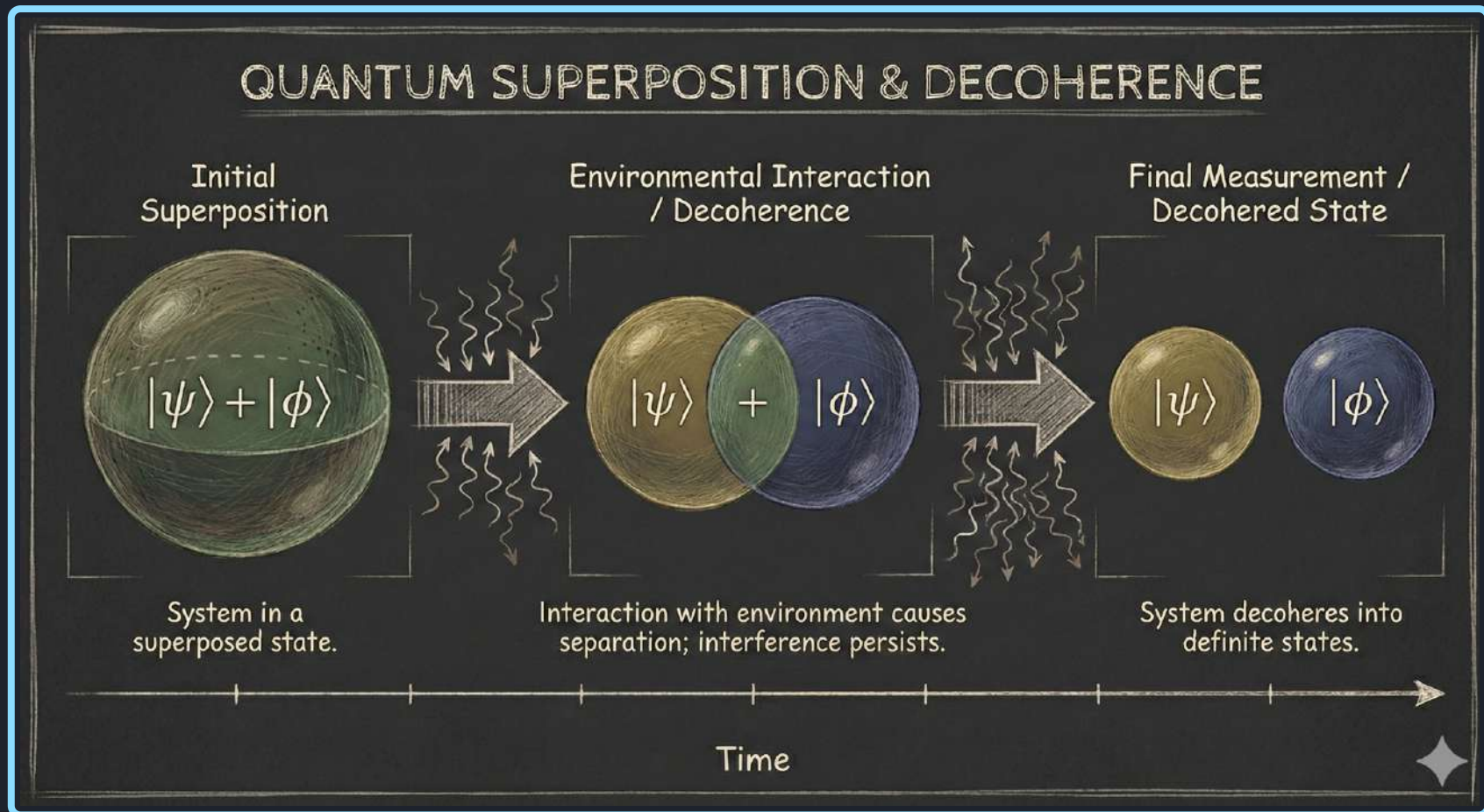

The major hurdle for quantum computing is decay of the quantum state (“decoherence”).

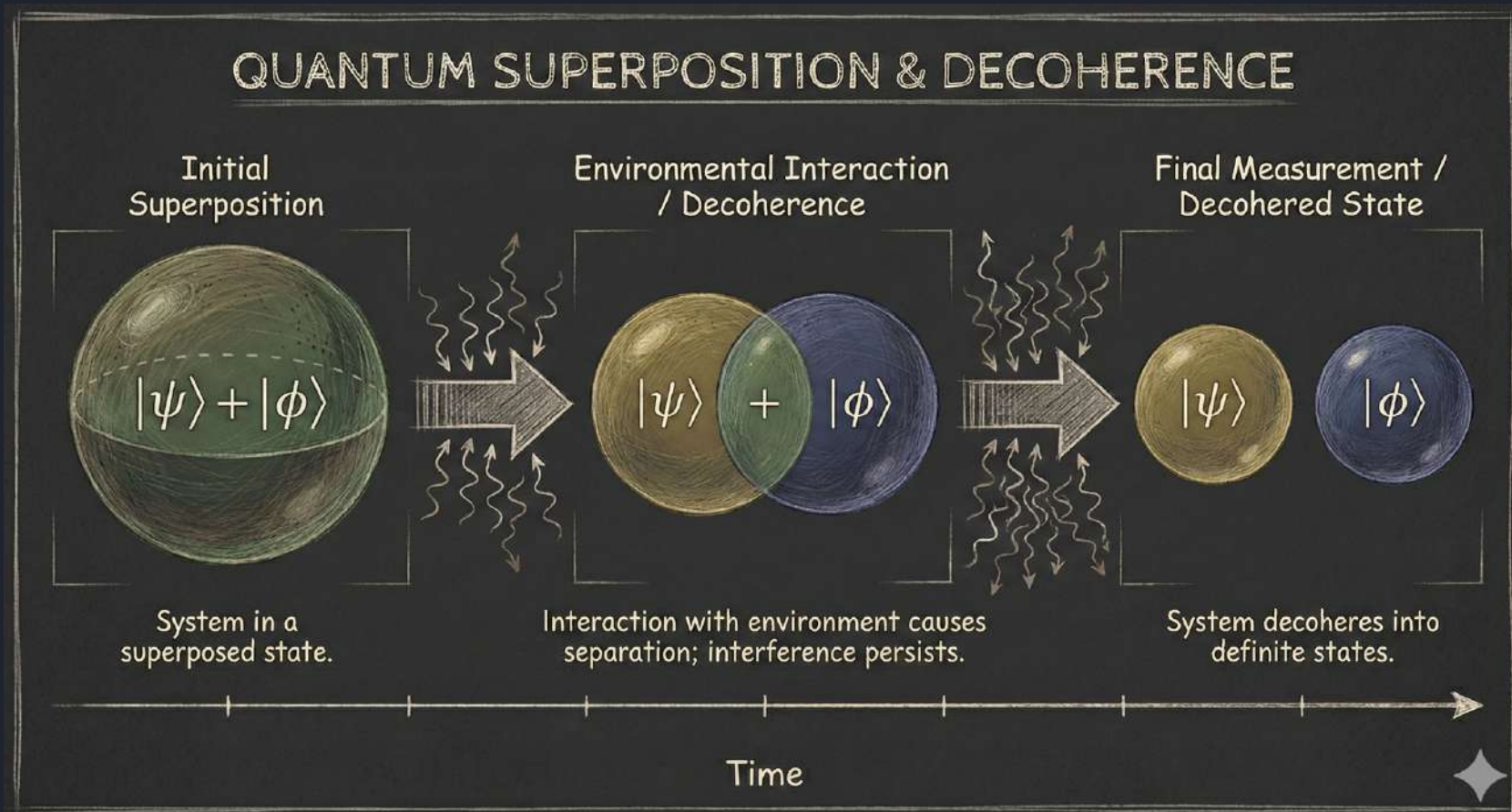

The power of quantum computing comes from *superposition* of quantum states,

The major hurdle for quantum computing is decay of the quantum state (“decoherence”).

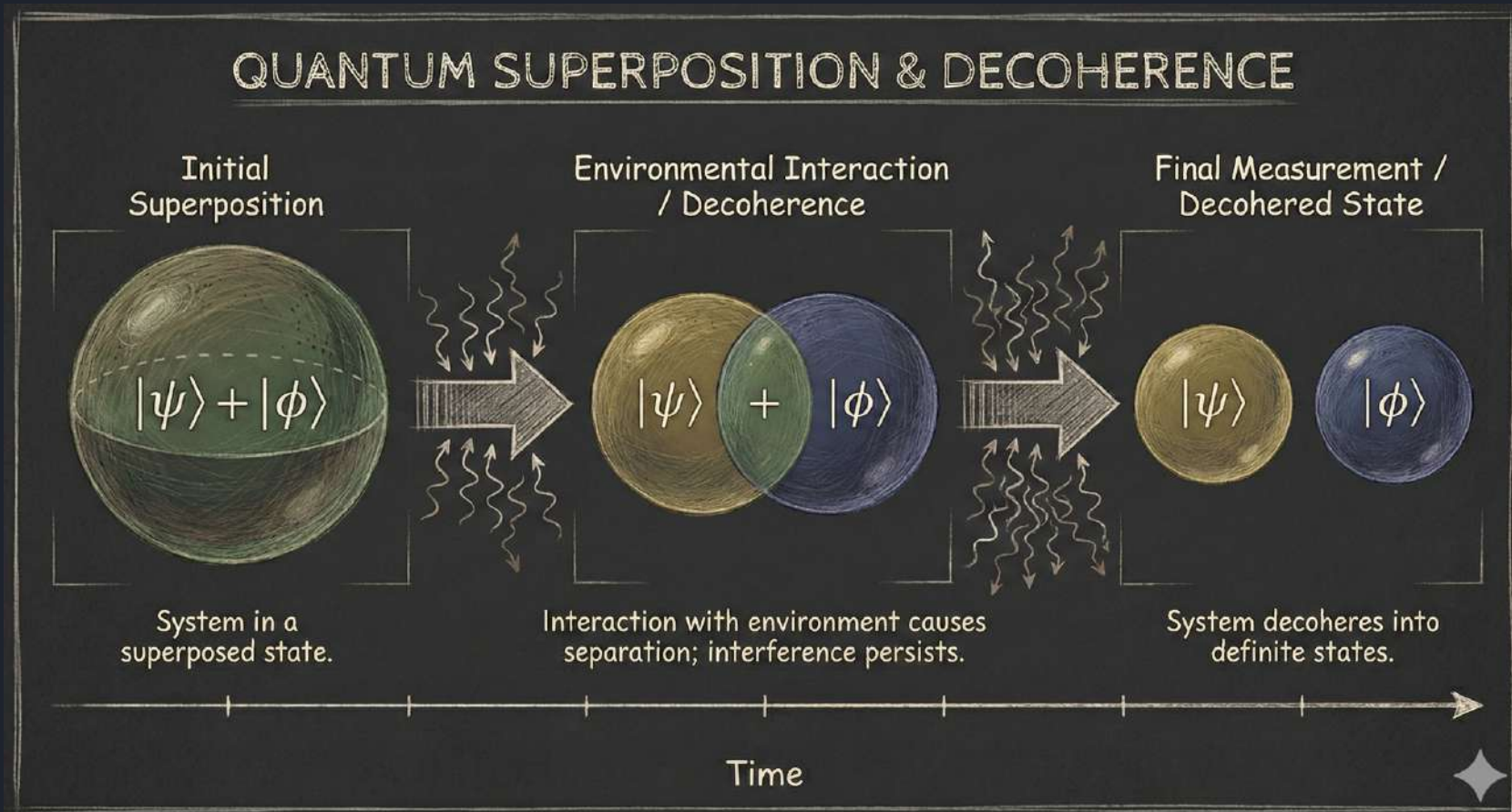

The power of quantum computing comes from *superposition* of quantum states, but this is easily destroyed by interactions with the environment

The major hurdle for quantum computing is decay of the quantum state (“decoherence”).

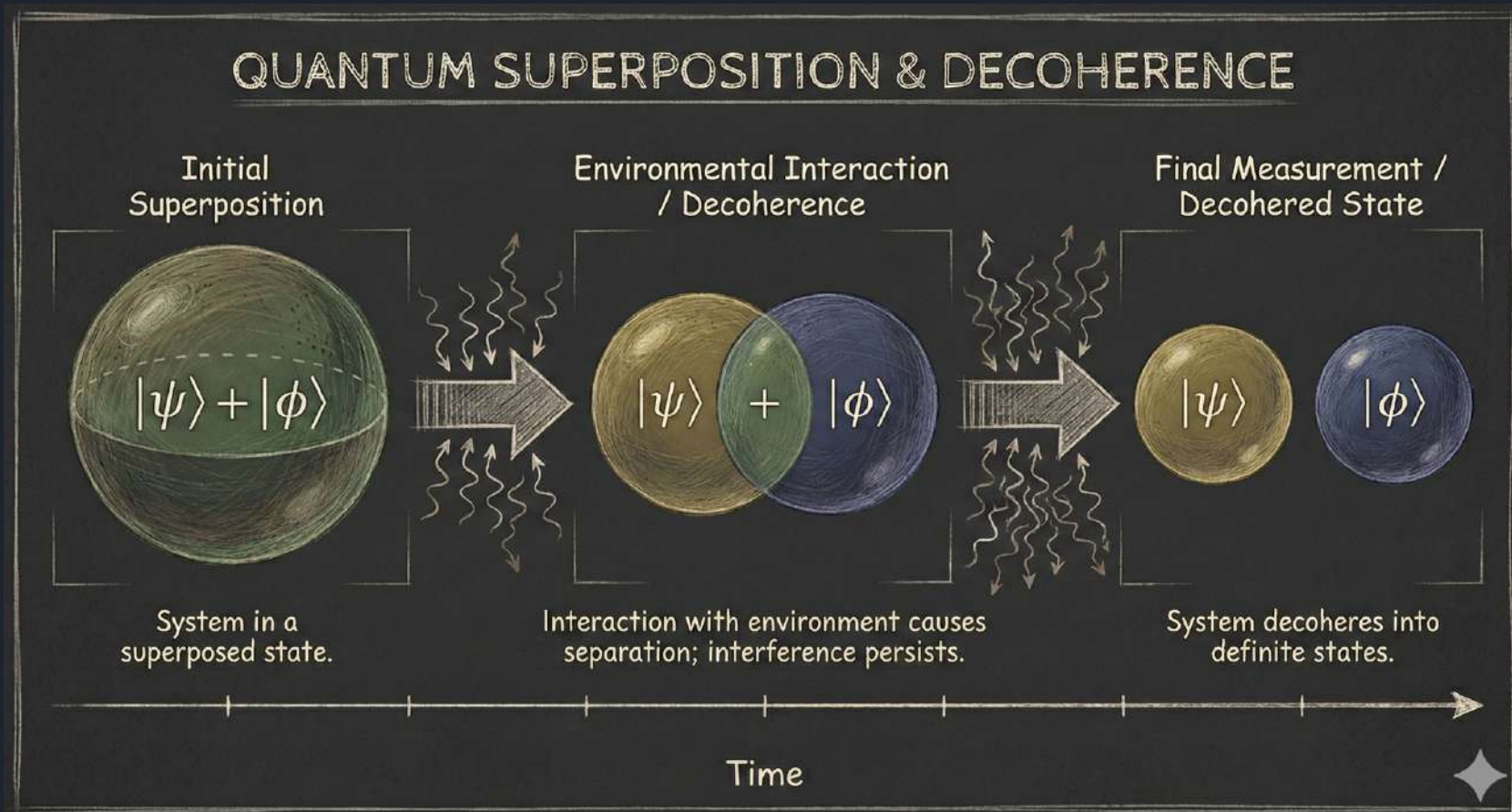

The power of quantum computing comes from *superposition* of quantum states, but this is easily destroyed by interactions with the environment

The currently dominant strategy towards future utility-scale quantum computers is *NISQ+QEC*:

The currently dominant strategy towards future utility-scale quantum computers is *NISQ+QEC*:

Unstable quantum memory, decaying in milliseconds, to be kept alive by *quantum error correction* (QEC):

The currently dominant strategy towards future utility-scale quantum computers is *NISQ+QEC*:

Unstable quantum memory, decaying in milliseconds, to be kept alive by *quantum error correction (QEC)*:

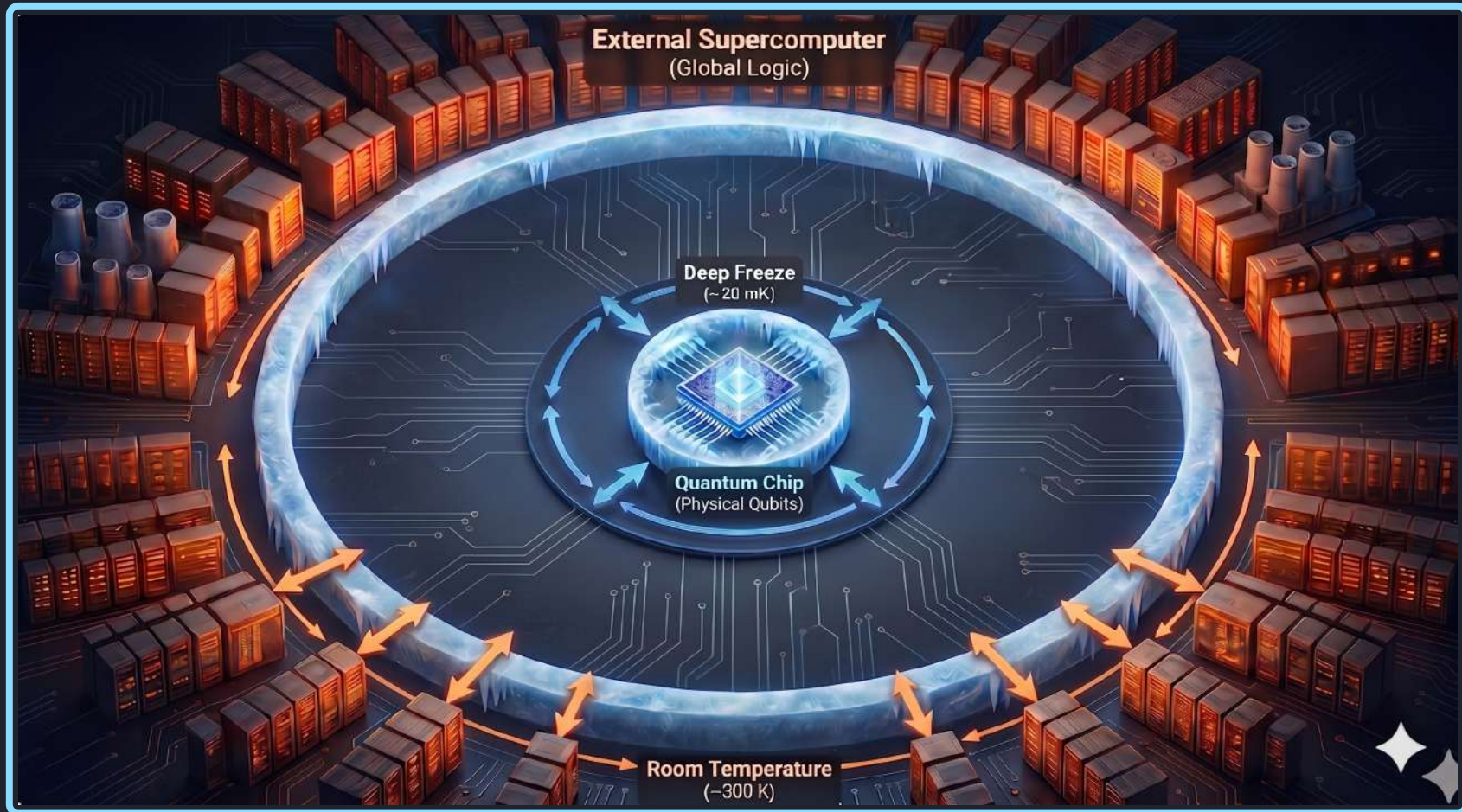

The currently dominant strategy towards future utility-scale quantum computers is *NISQ+QEC*:

Unstable quantum memory, decaying in milliseconds, to be kept alive by *quantum error correction (QEC)*:

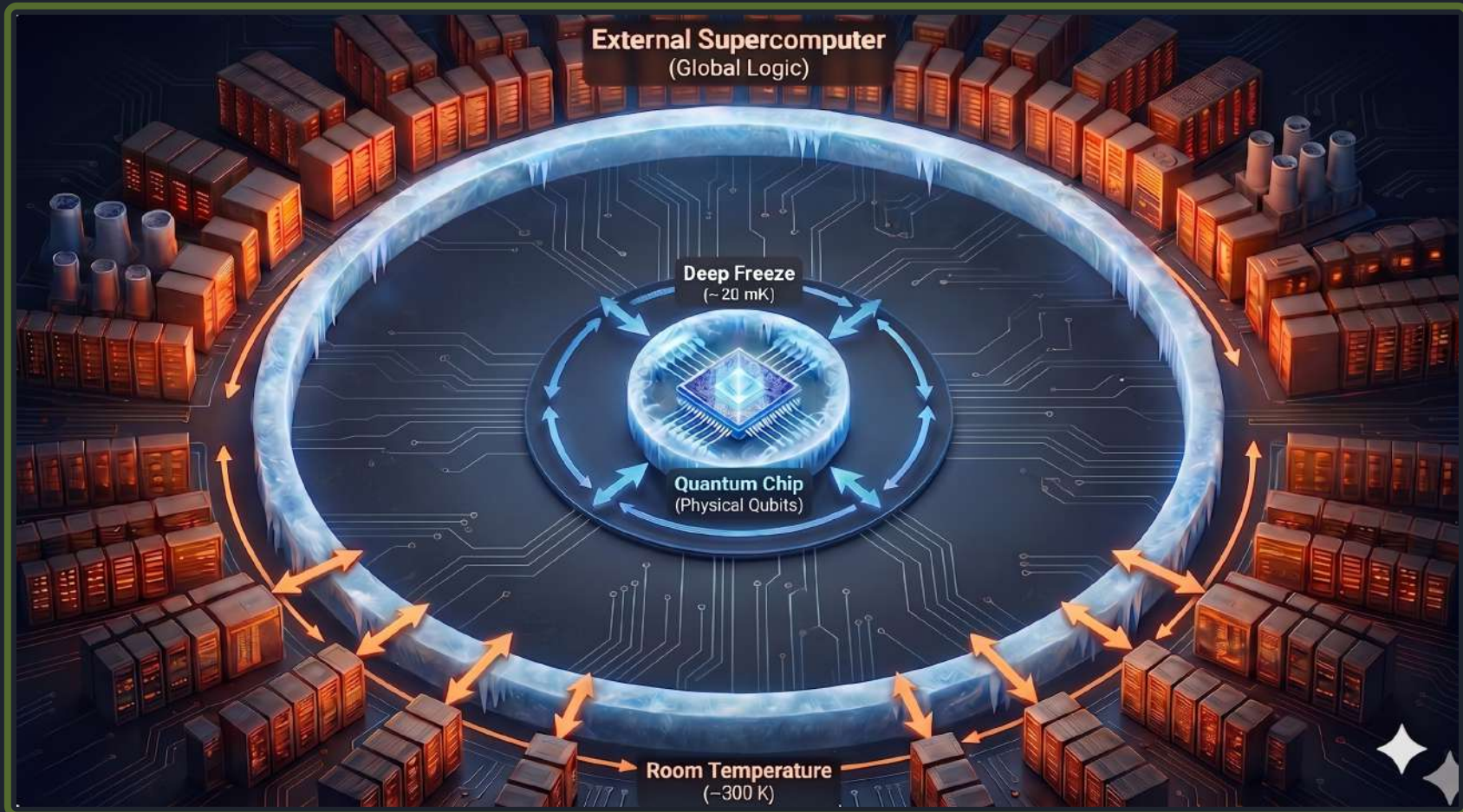

QEC alone will require novel classical *supercomputers*

The currently dominant strategy towards future utility-scale quantum computers is *NISQ+QEC*:

Unstable quantum memory, decaying in milliseconds, to be kept alive by *quantum error correction (QEC)*:

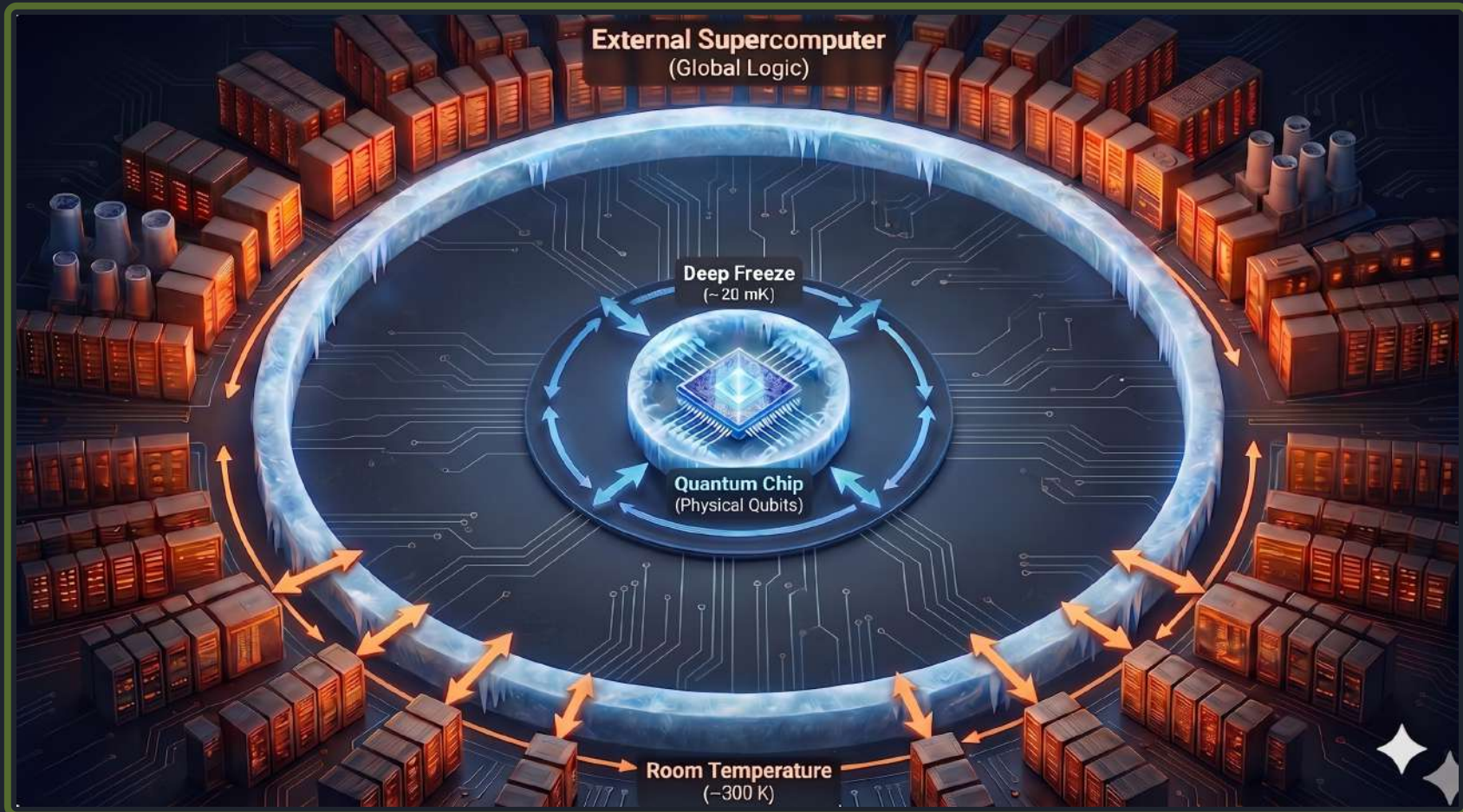

QEC alone will require novel classical *supercomputers* operating under presently inaccessible conditions!

The currently dominant strategy towards future utility-scale quantum computers is *NISQ+QEC*:

Unstable quantum memory, decaying in milliseconds, to be kept alive by *quantum error correction* (QEC):

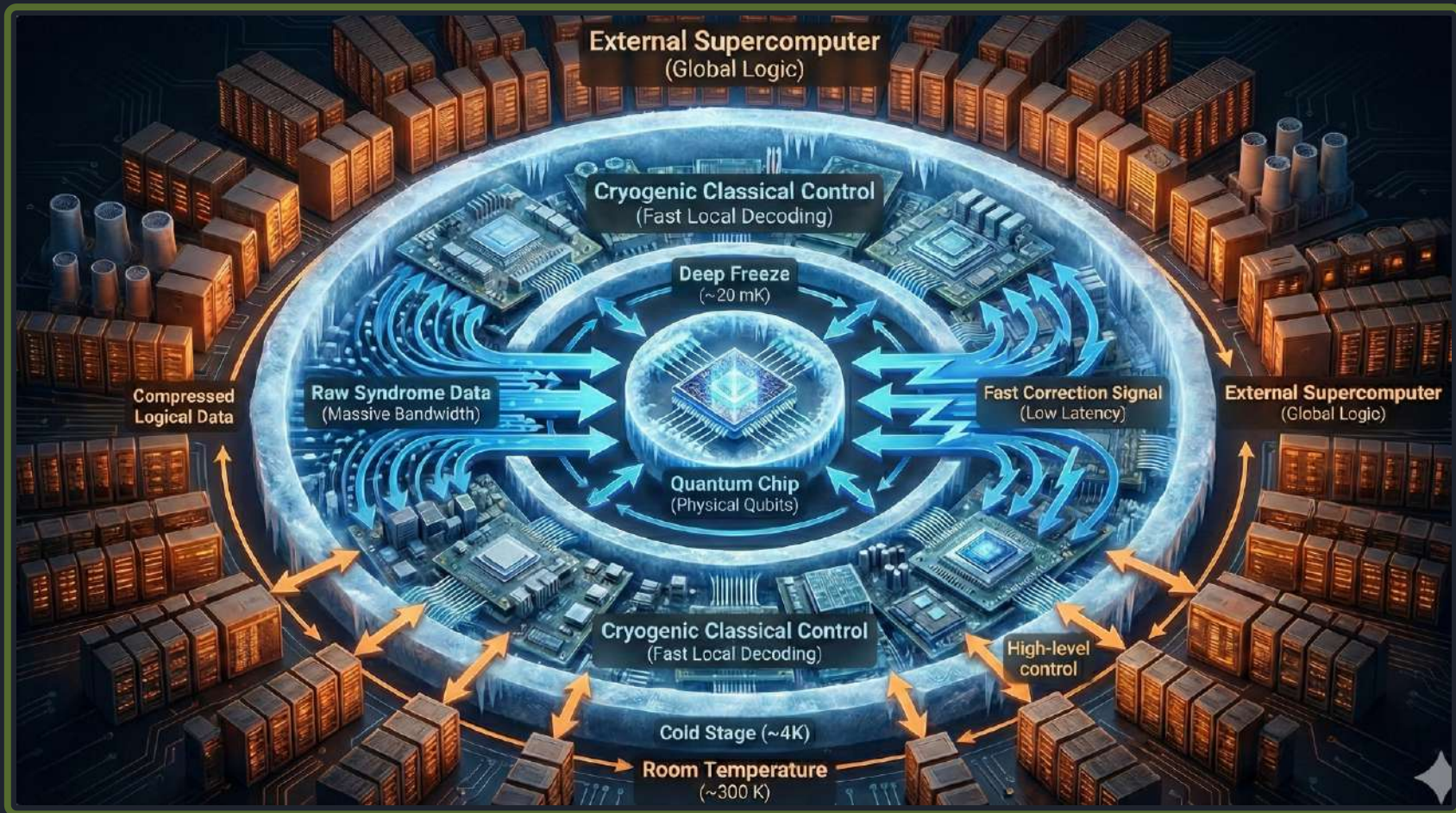

QEC alone will require novel classical *supercomputers* operating under presently inaccessible conditions!

The currently dominant strategy towards future utility-scale quantum computers is *NISQ+QEC*:

Unstable quantum memory, decaying in milliseconds, to be kept alive by *quantum error correction* (QEC):

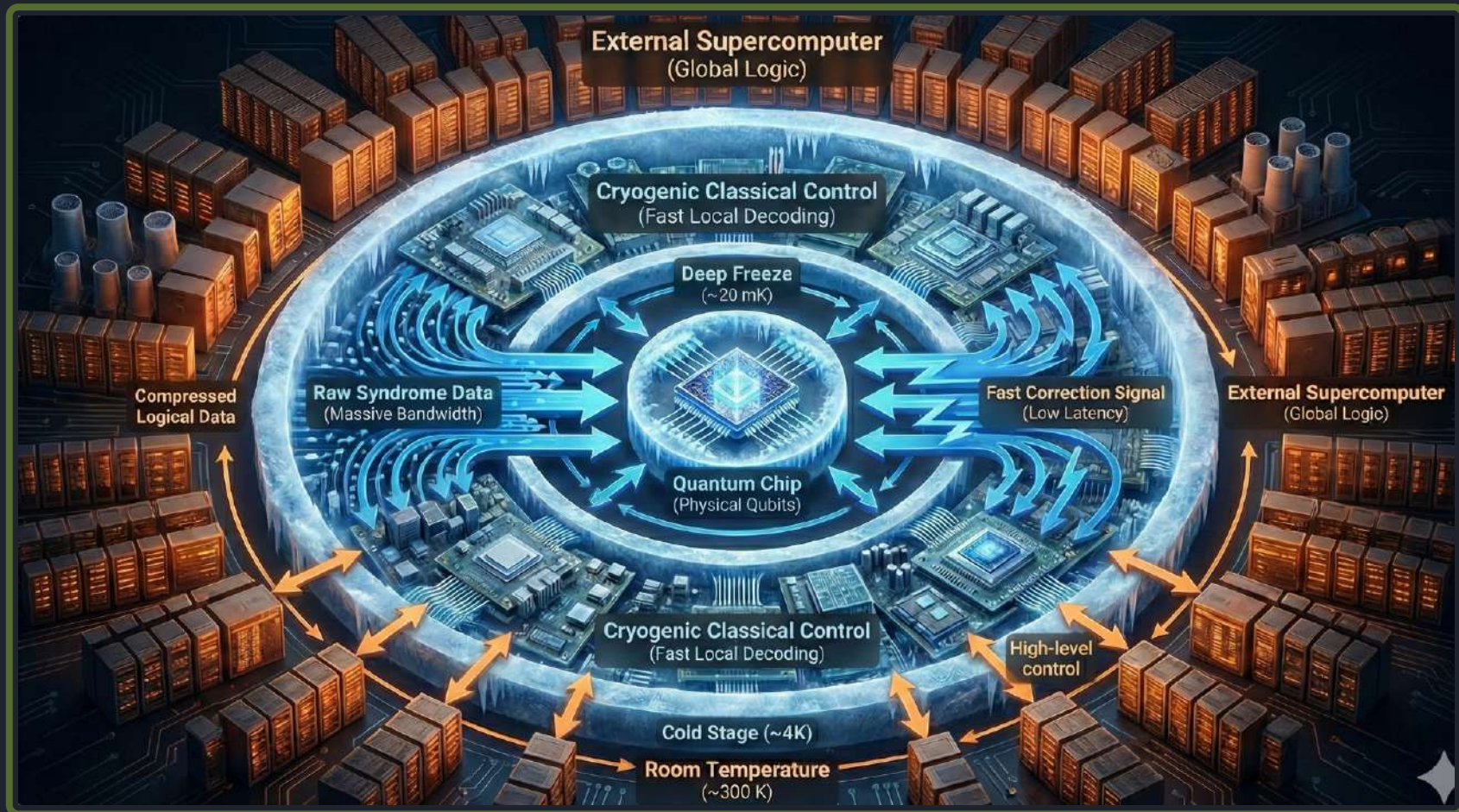

QEC alone will require novel classical *supercomputers* operating under presently inaccessible conditions!

In short, QEC is like frantically refilling leaking buckets.

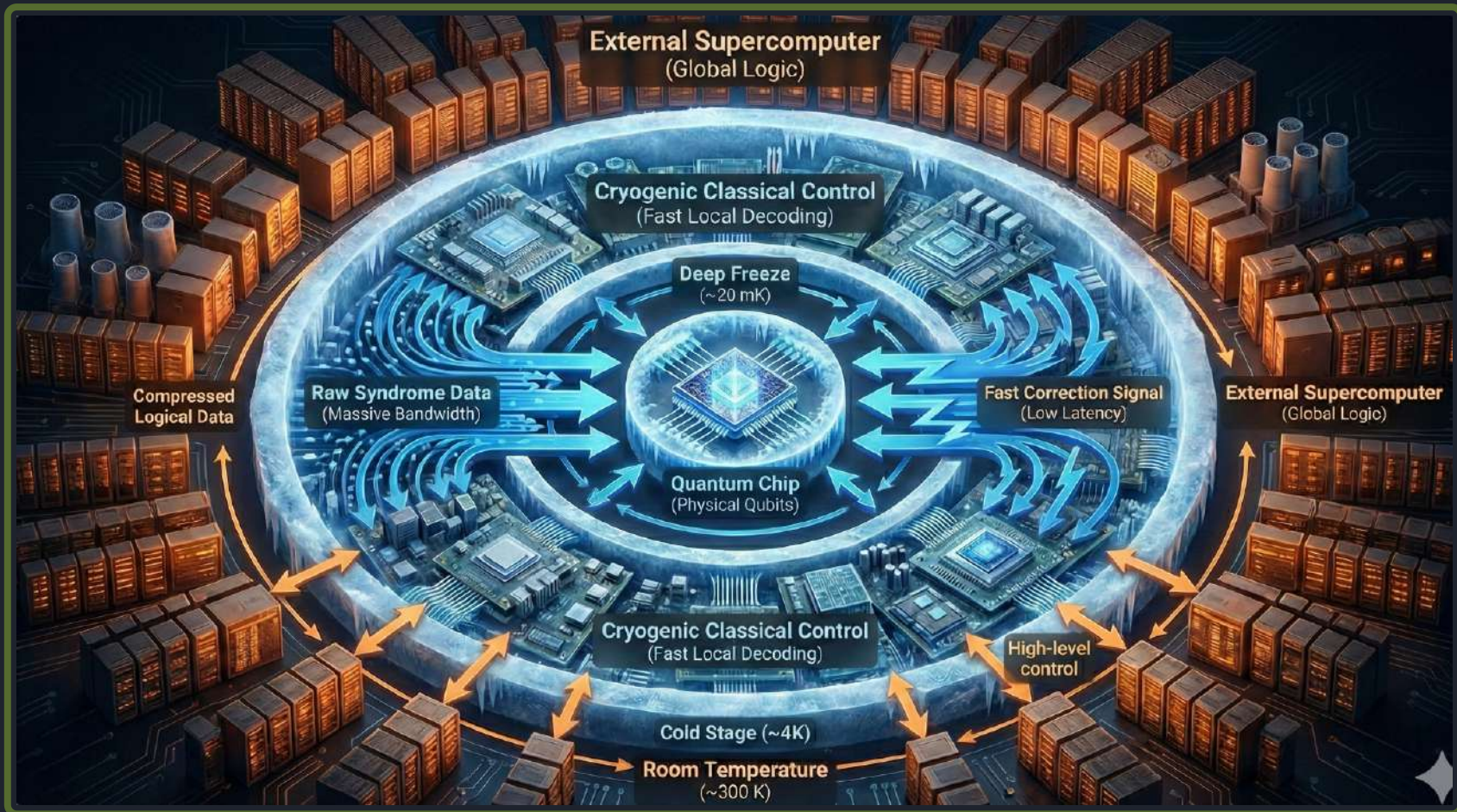

QEC alone will require novel classical *supercomputers* operating under presently inaccessible conditions!

In short, QEC is like frantically refilling leaking buckets.

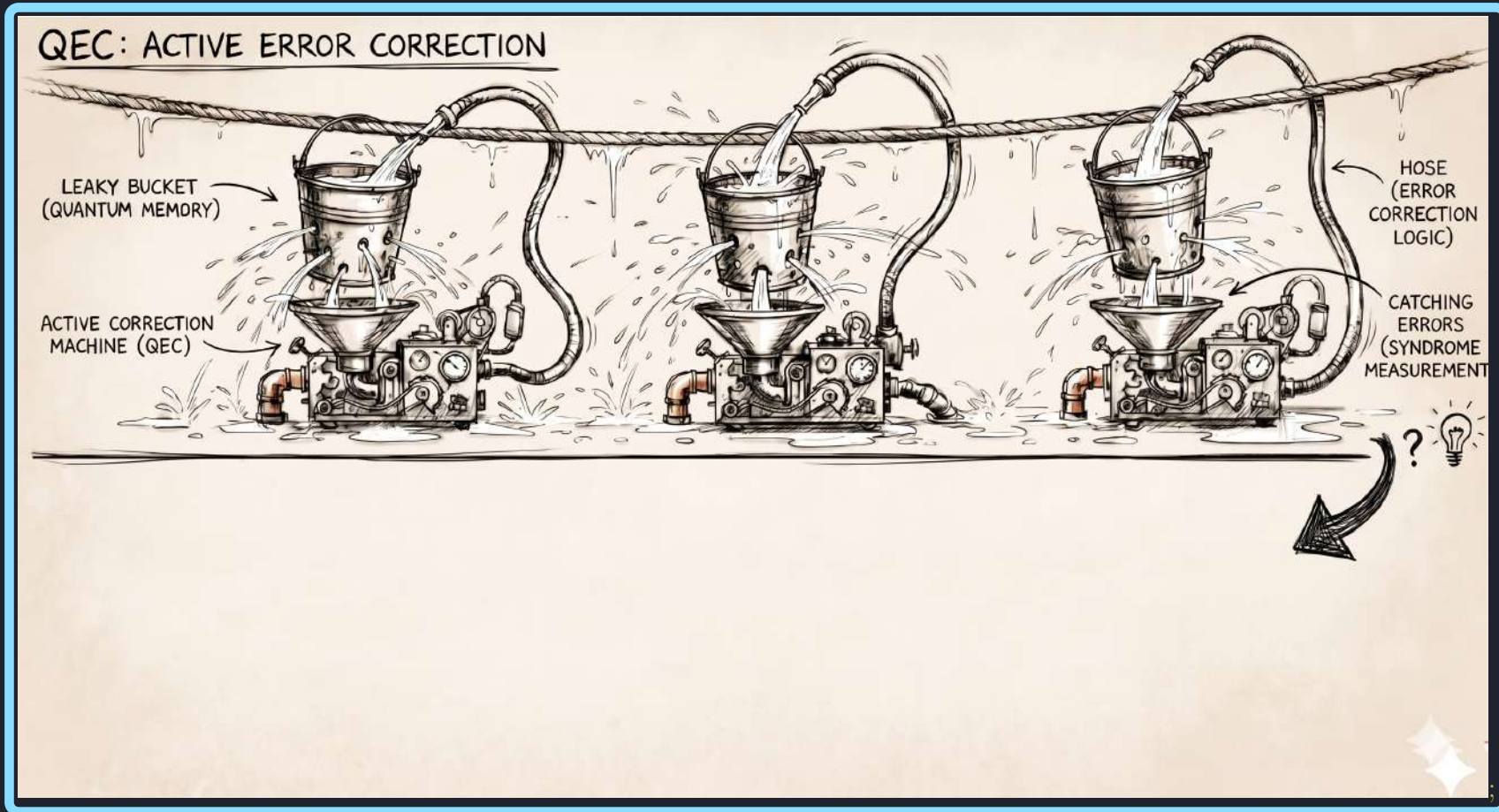

In short, QEC is like frantically refilling leaking buckets.
More fundamental fix would be to: Plug the buckets!

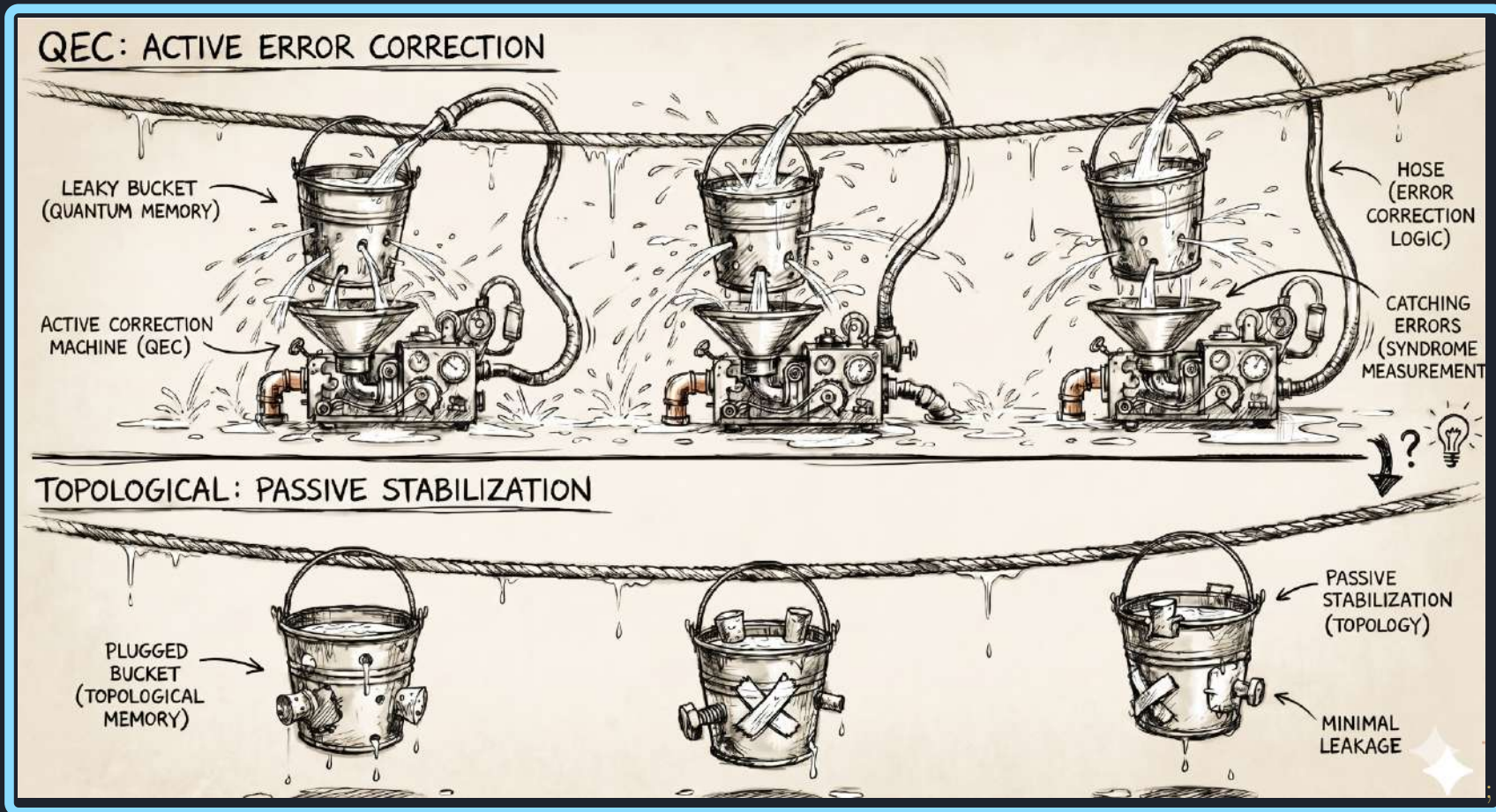

In short, QEC is like frantically refilling leaking buckets.
More fundamental fix would be to: Plug the buckets!

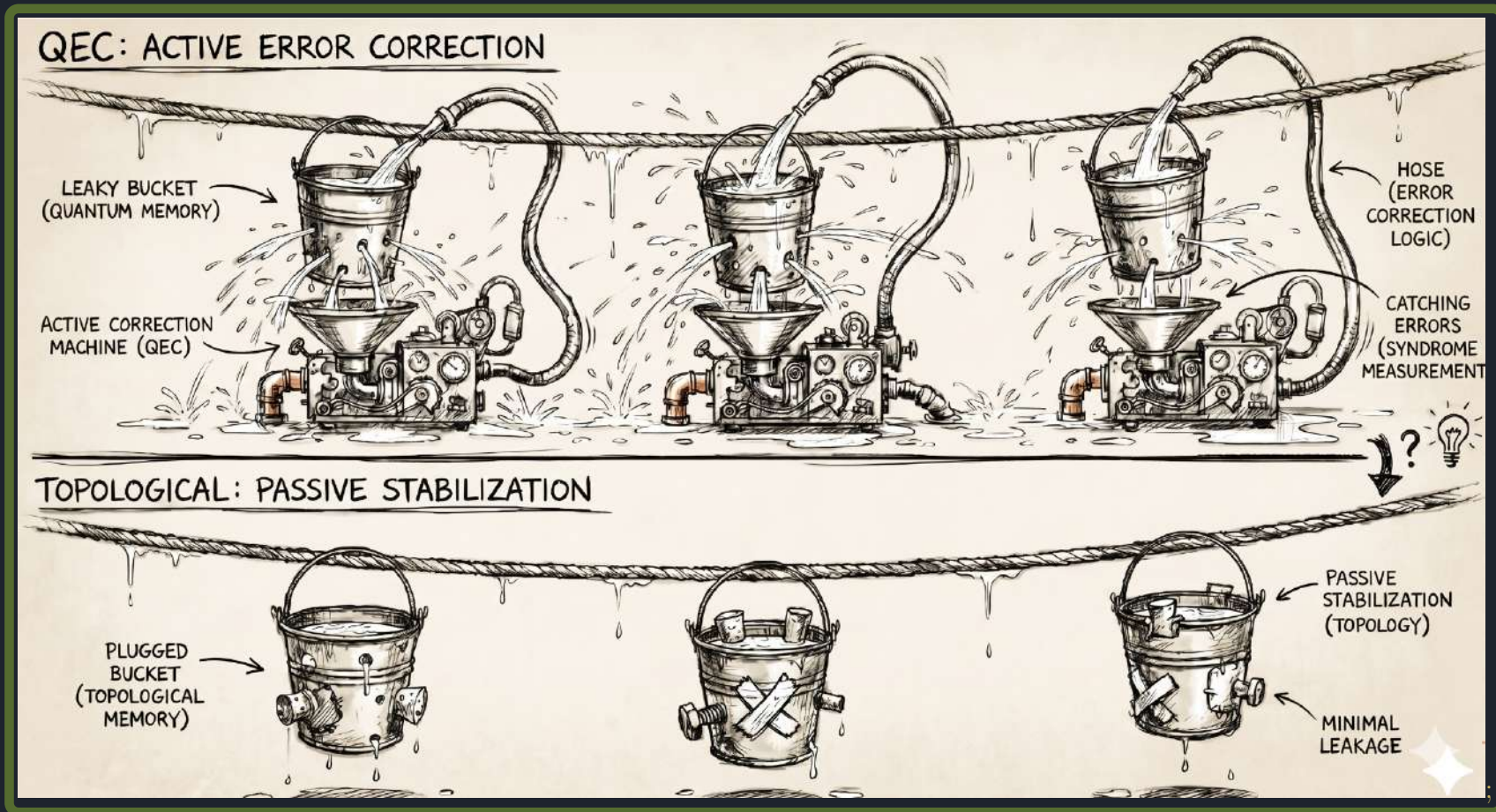

This fundamental fix is *topological quantum*:
Intrinsically stabilized quantum states by topology.

In short, QEC is like frantically refilling leaking buckets.
More fundamental fix would be to: Plug the buckets!

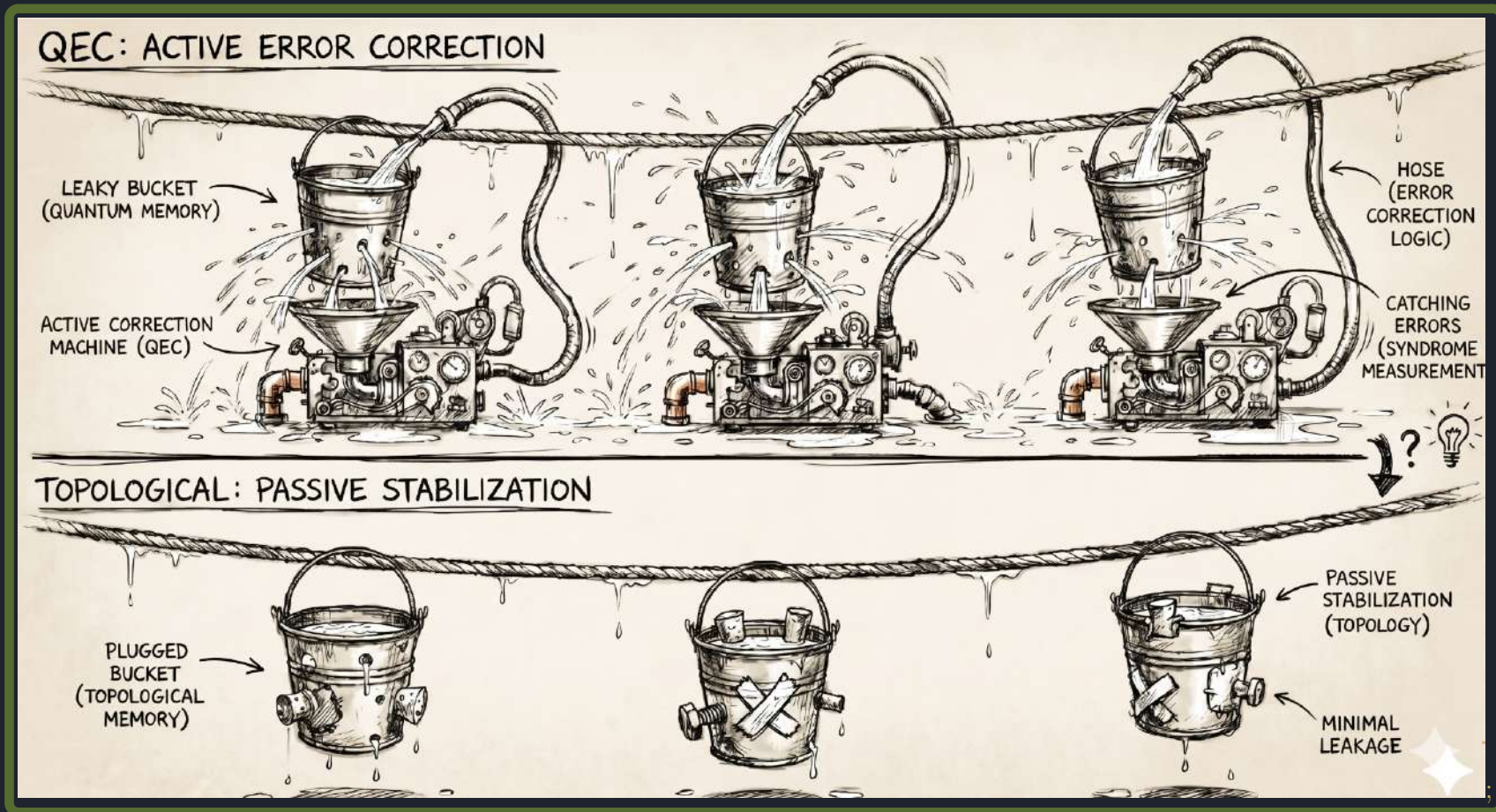

This fundamental fix is *topological quantum*:
Intrinsically stabilized quantum states by topology.

A candidate platform for such topological stabilization are just the FQH liquids, discussed earlier

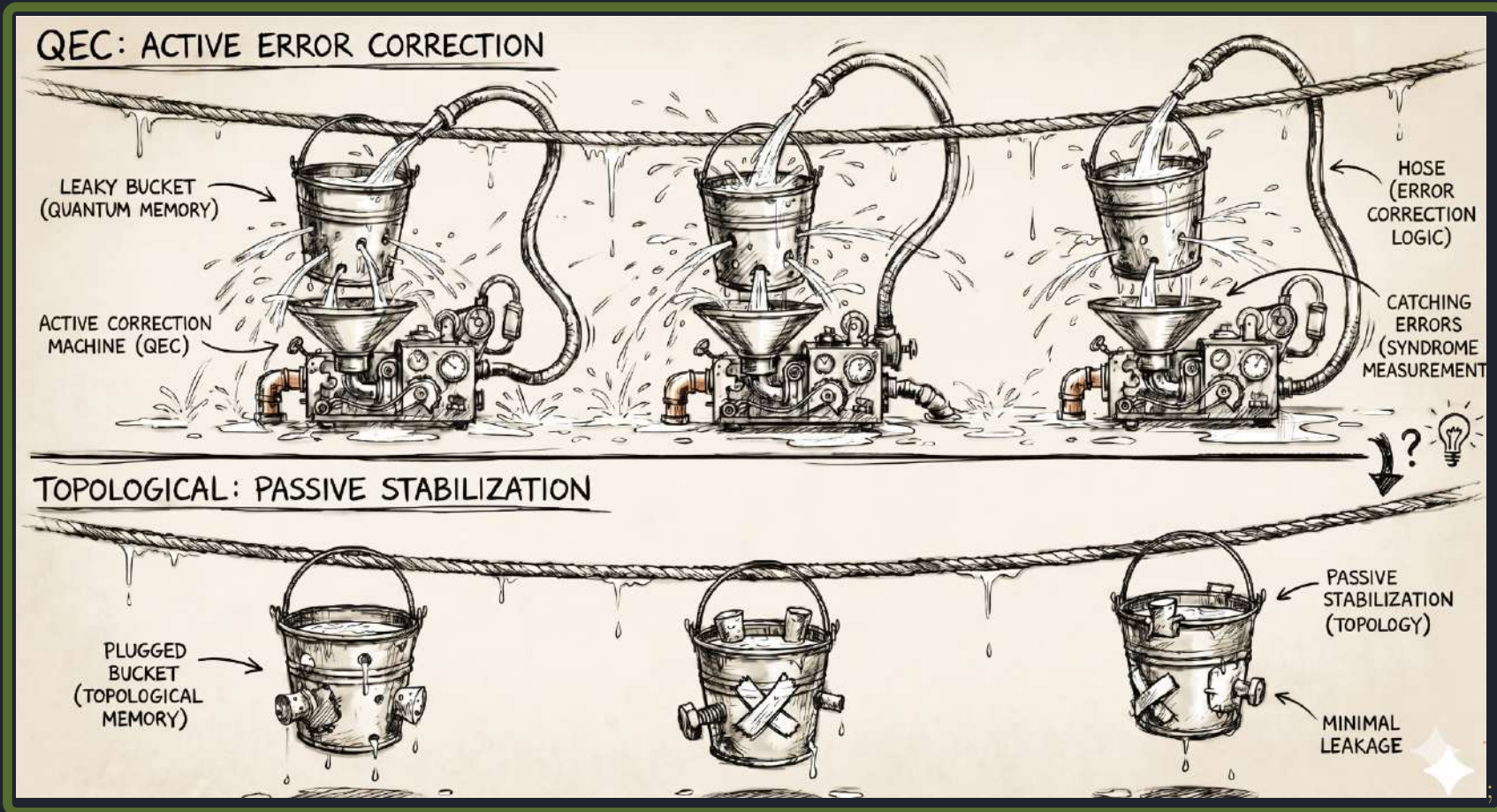

A candidate platform for such topological stabilization
are just the FQH liquids, discussed earlier
since the braiding phase is insensitive to local noise

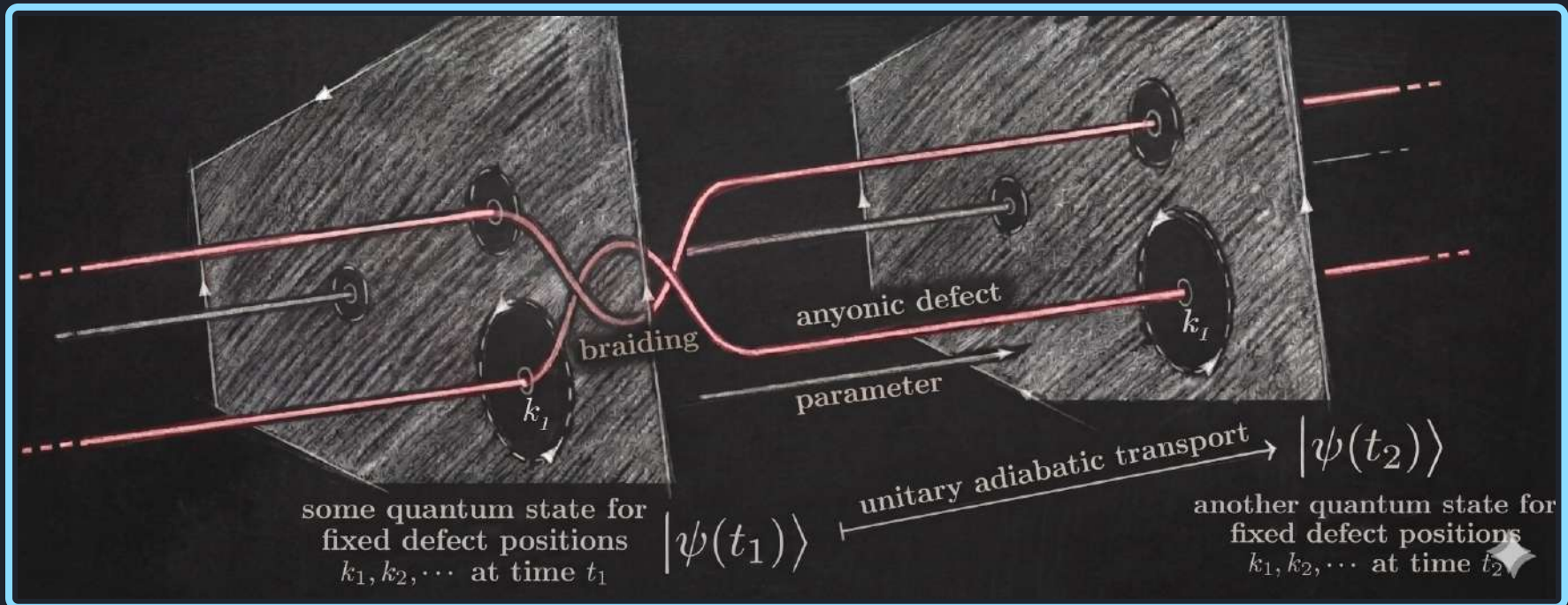

A candidate platform for such topological stabilization
are just the FQH liquids, discussed earlier
since the braiding phase is insensitive to local noise

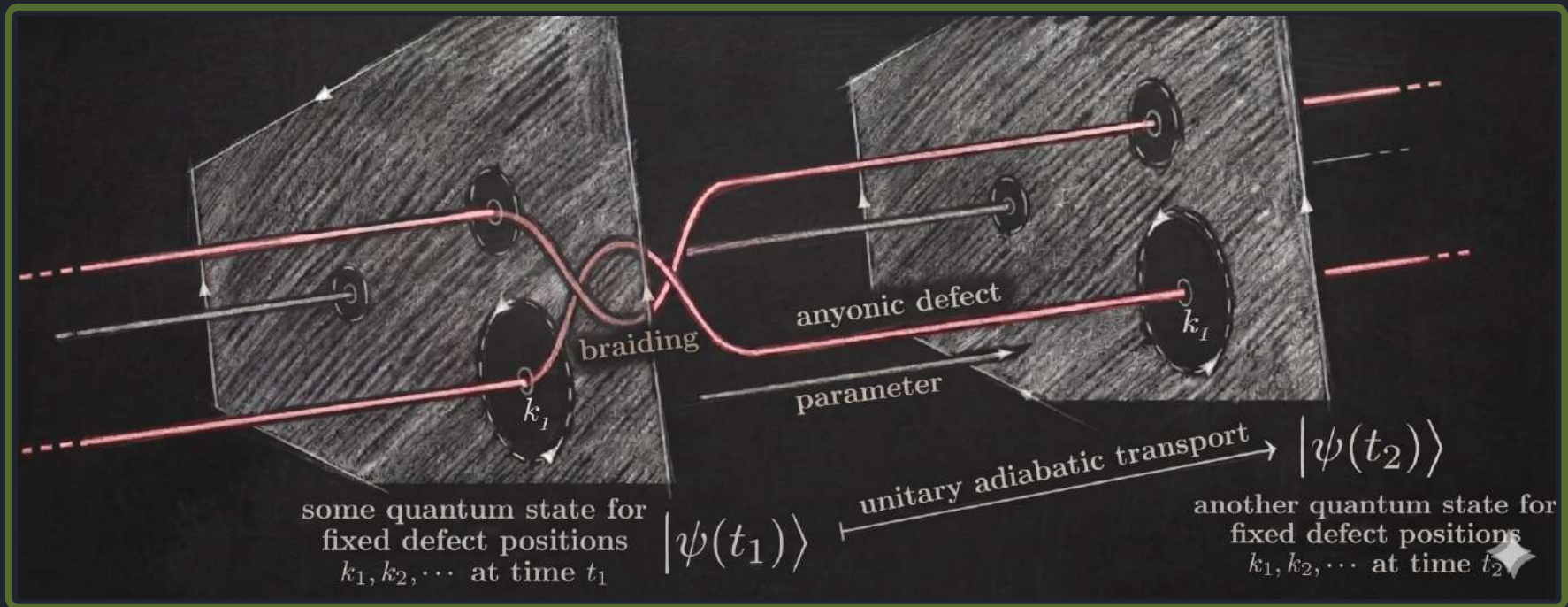

These (abelian) braiding phases have been observed(!)

A candidate platform for such topological stabilization
are just the FQH liquids, discussed earlier
since the braiding phase is insensitive to local noise

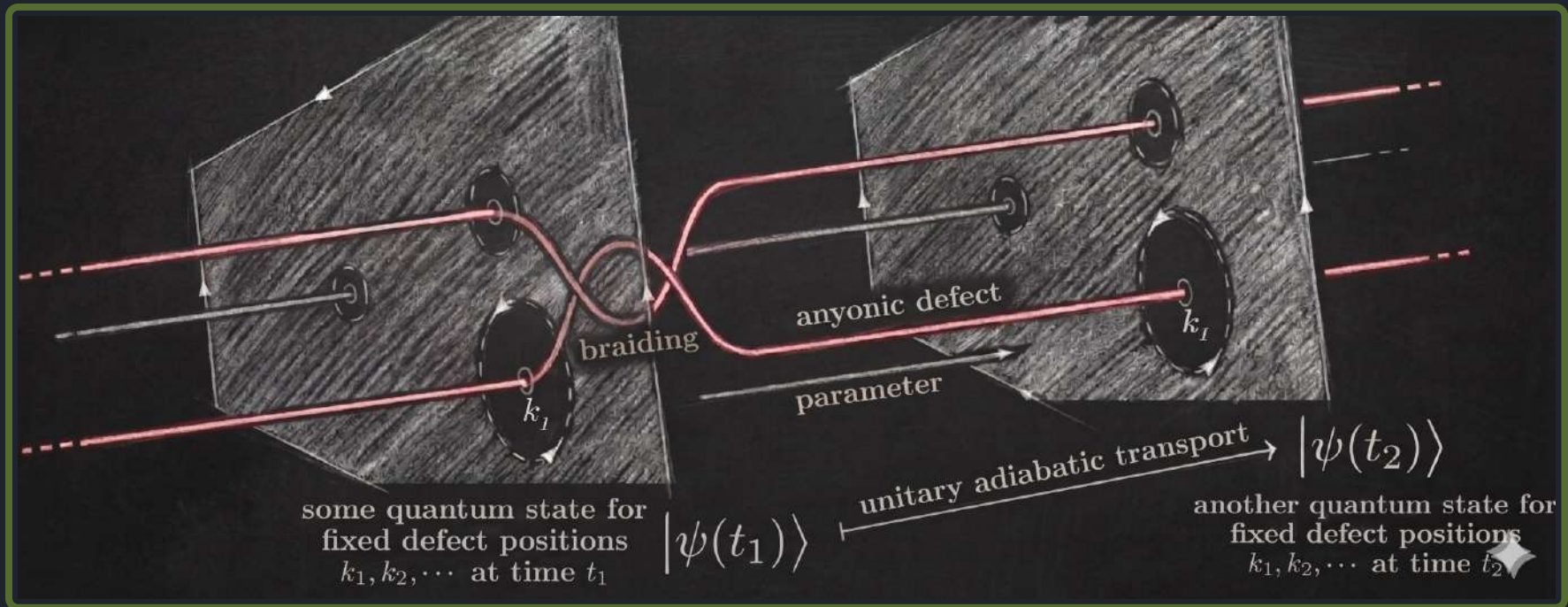

These (abelian) braiding phases have been observed(!)

but many open questions remain, such as
concerning nonabelian and controlled braiding.

A candidate platform for such topological stabilization
are just the FQH liquids, discussed earlier
since the braiding phase is insensitive to local noise

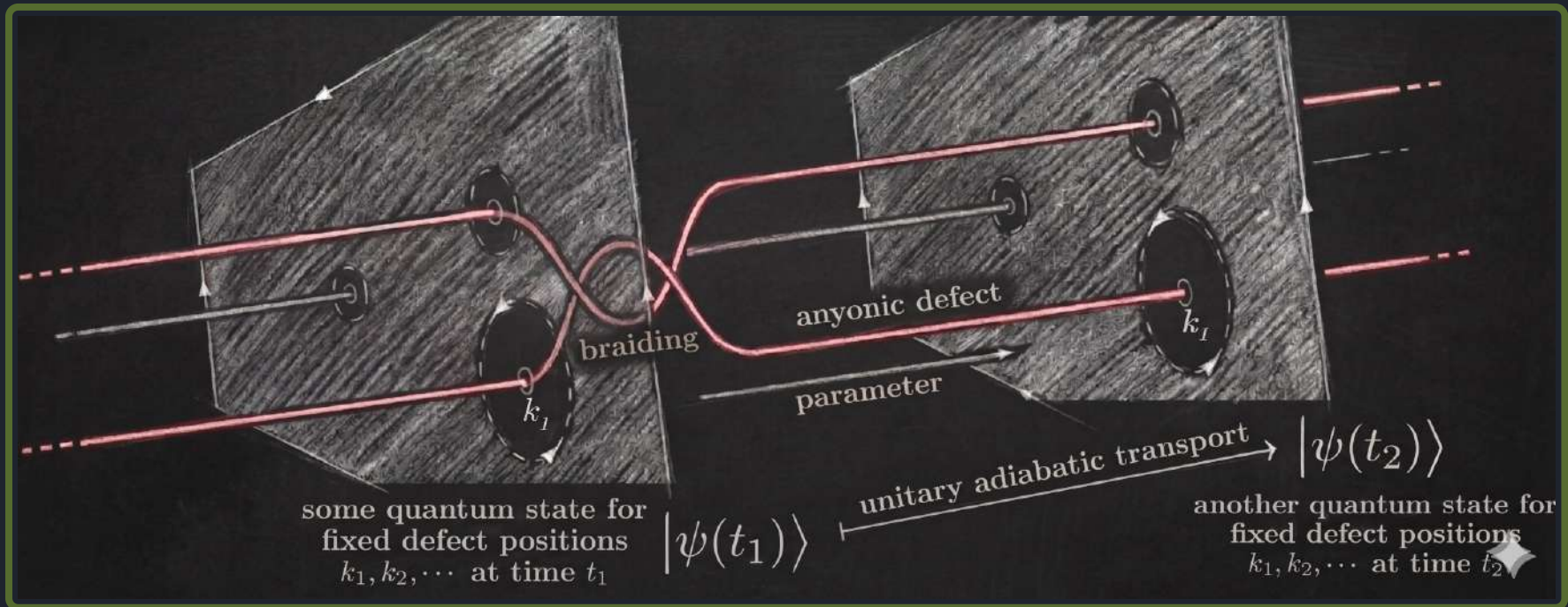

These (abelian) braiding phases have been observed(!)

but many open questions remain, such as
concerning nonabelian and controlled braiding.

Q: So how to actually understand
non-perturbative physical fields?

Q: So how to actually understand
non-perturbative physical fields?

A: *Flux Quantization* \Rightarrow



Q: So how to actually understand
non-perturbative physical fields?

A: *Flux Quantization* \Rightarrow

solitons,

Q: So how to actually understand
non-perturbative physical fields?

A: *Flux Quantization* \Rightarrow

solitons,
monopoles,

Q: So how to actually understand
non-perturbative physical fields?

A: *Flux Quantization* \Rightarrow

solitons,
monopoles,
skyrmions,

Q: So how to actually understand
non-perturbative physical fields?

A: *Flux Quantization* \Rightarrow

solitons,
monopoles,
skyrmions,
instantons,

Q: So how to actually understand
non-perturbative physical fields?

A: *Flux Quantization* \Rightarrow

solitons,
monopoles,
skyrmions,
instantons,
...

Q: So how to actually understand
non-perturbative physical fields?

A: *Flux Quantization* \Rightarrow

solitons,
monopoles,
skyrmions,
instantons,
...



Encyclopedia of Mathematical Physics (Second Edition)

Volume 4, 2025, Pages 281-324

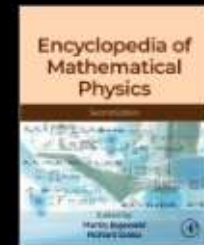

Flux Quantization

Hisham Sati, Urs Schreiber

Q: So how to actually understand
non-perturbative physical fields?

A: *Flux Quantization* \Rightarrow

solitons,
monopoles,
skyrmions,
instantons,
...



Encyclopedia of Mathematical Physics (Second Edition)

Volume 4, 2025, Pages 281-324

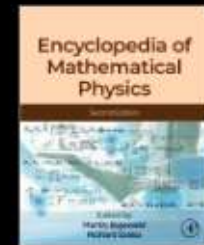

Flux Quantization

Hisham Sati, Urs Schreiber

In 1852, Michael Faraday strewed
iron filings over the poles of a magnet

In 1852, Michael Faraday strewed iron filings over the poles of a magnet

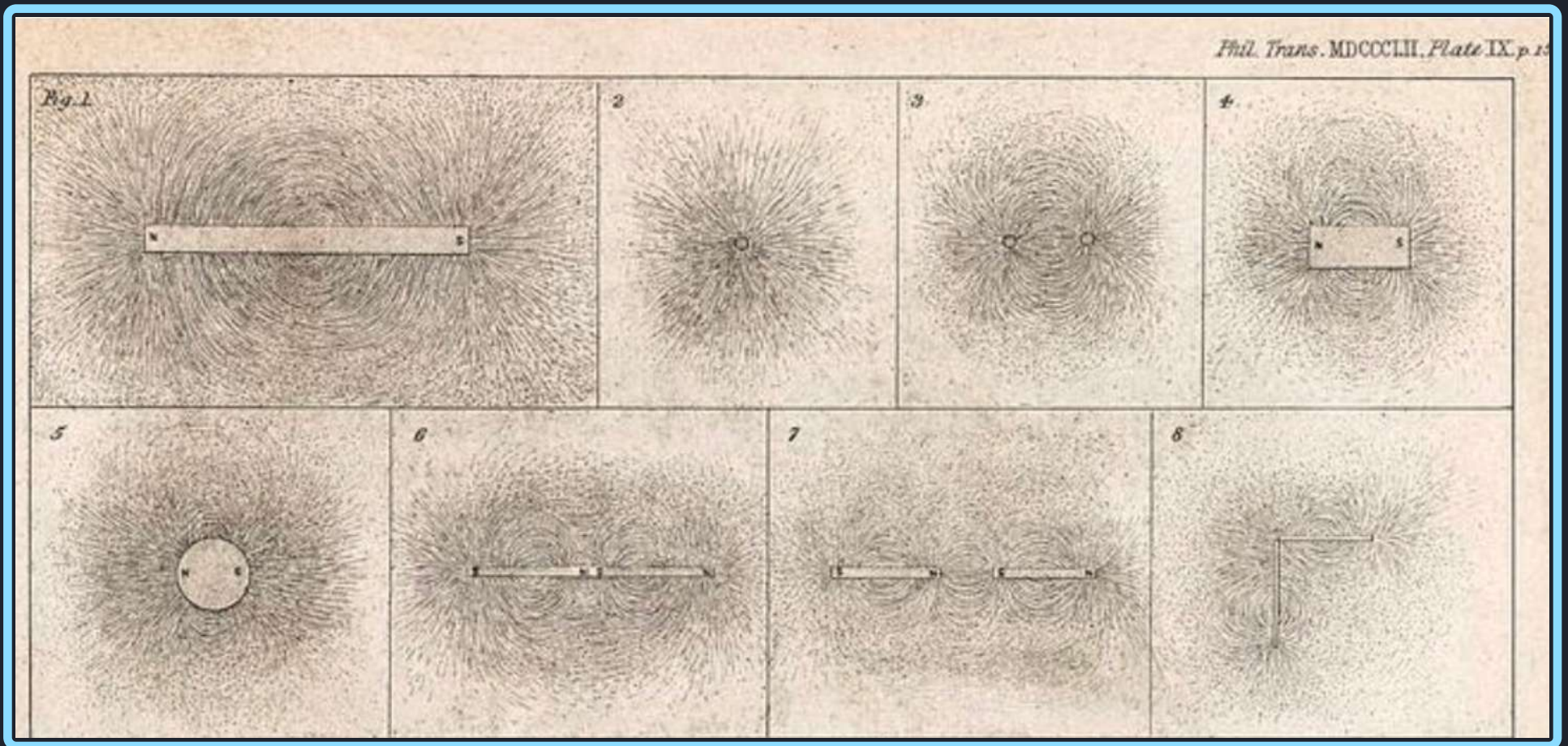

In 1852, Michael Faraday strewed iron filings over the poles of a magnet

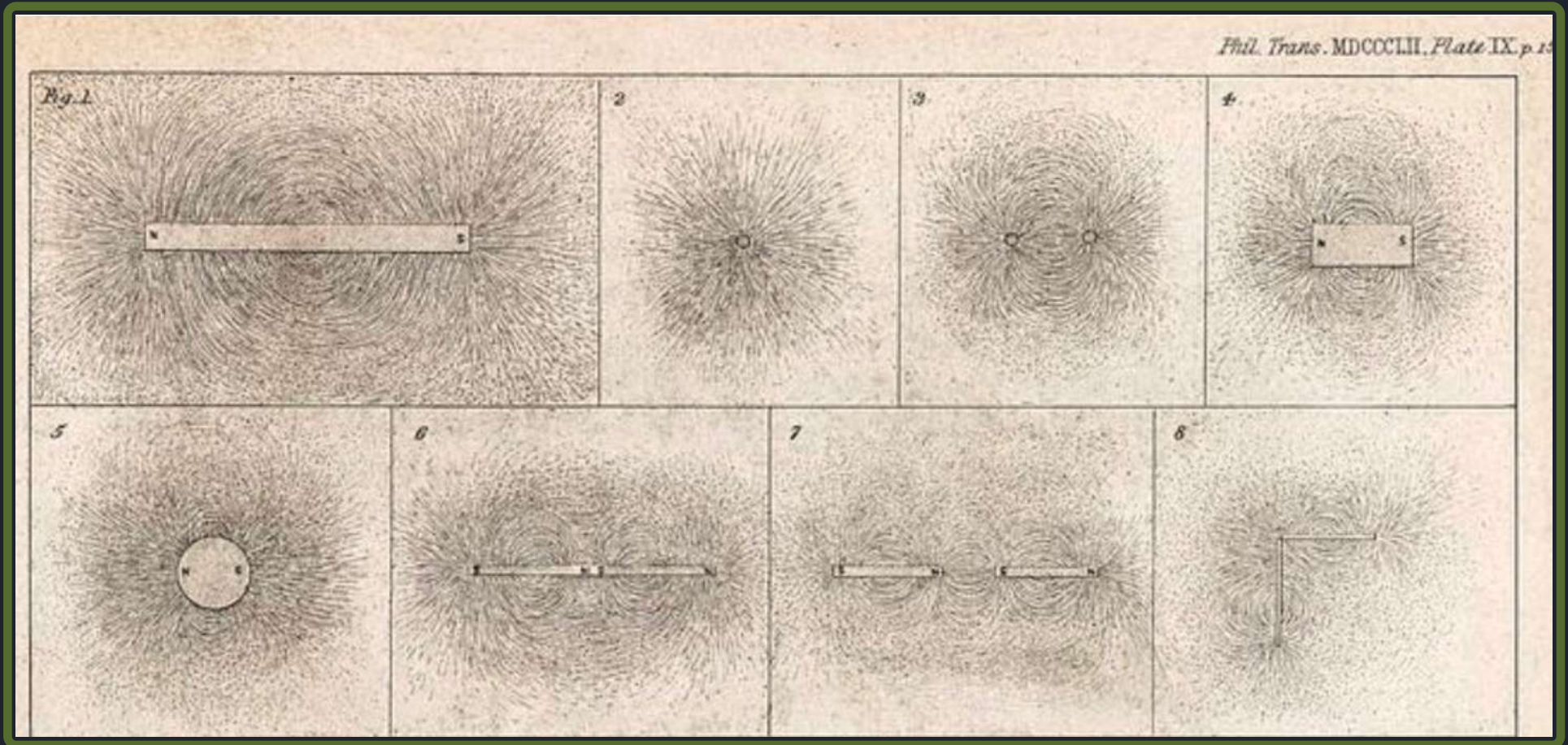

This revealed *magnetic flux lines* sourced by the magnetic poles.

In 1852, Michael Faraday strewed iron filings over the poles of a magnet

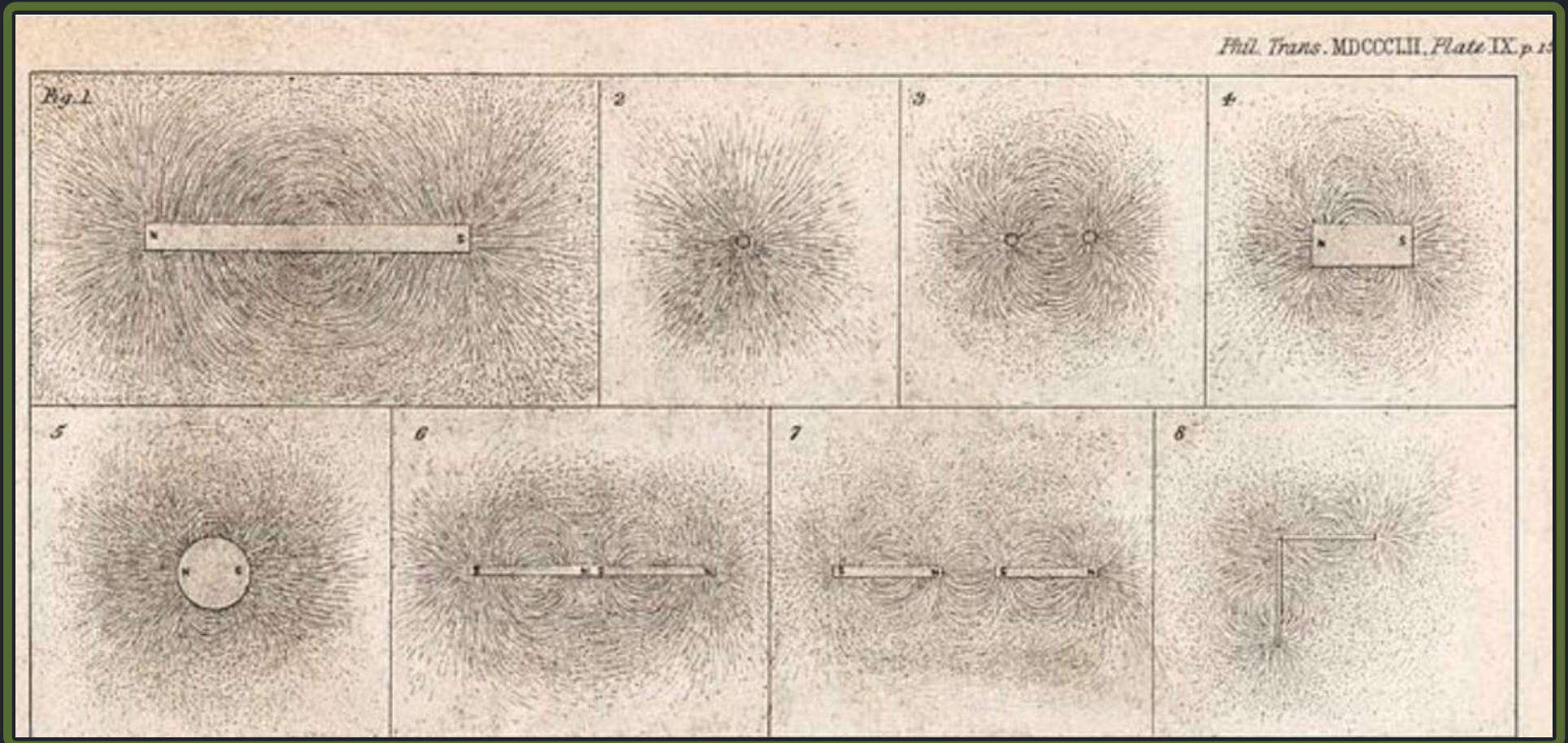

This revealed *magnetic flux lines* sourced by the magnetic poles.

In 1852, Michael Faraday strewed iron filings over the poles of a magnet

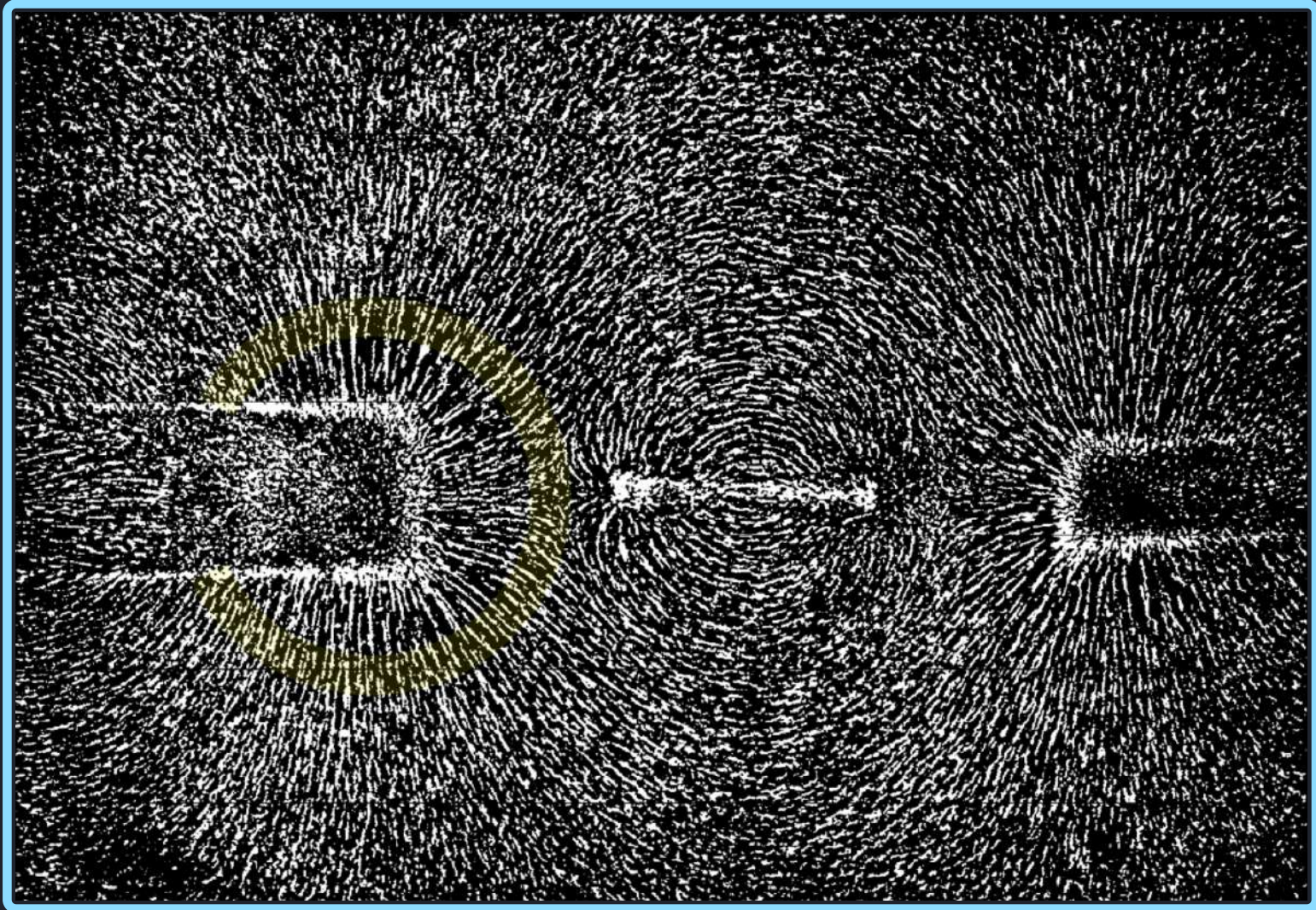

This revealed *magnetic flux lines* sourced by the magnetic poles.

In 1852, Michael Faraday strewed
iron filings over the poles of a magnet

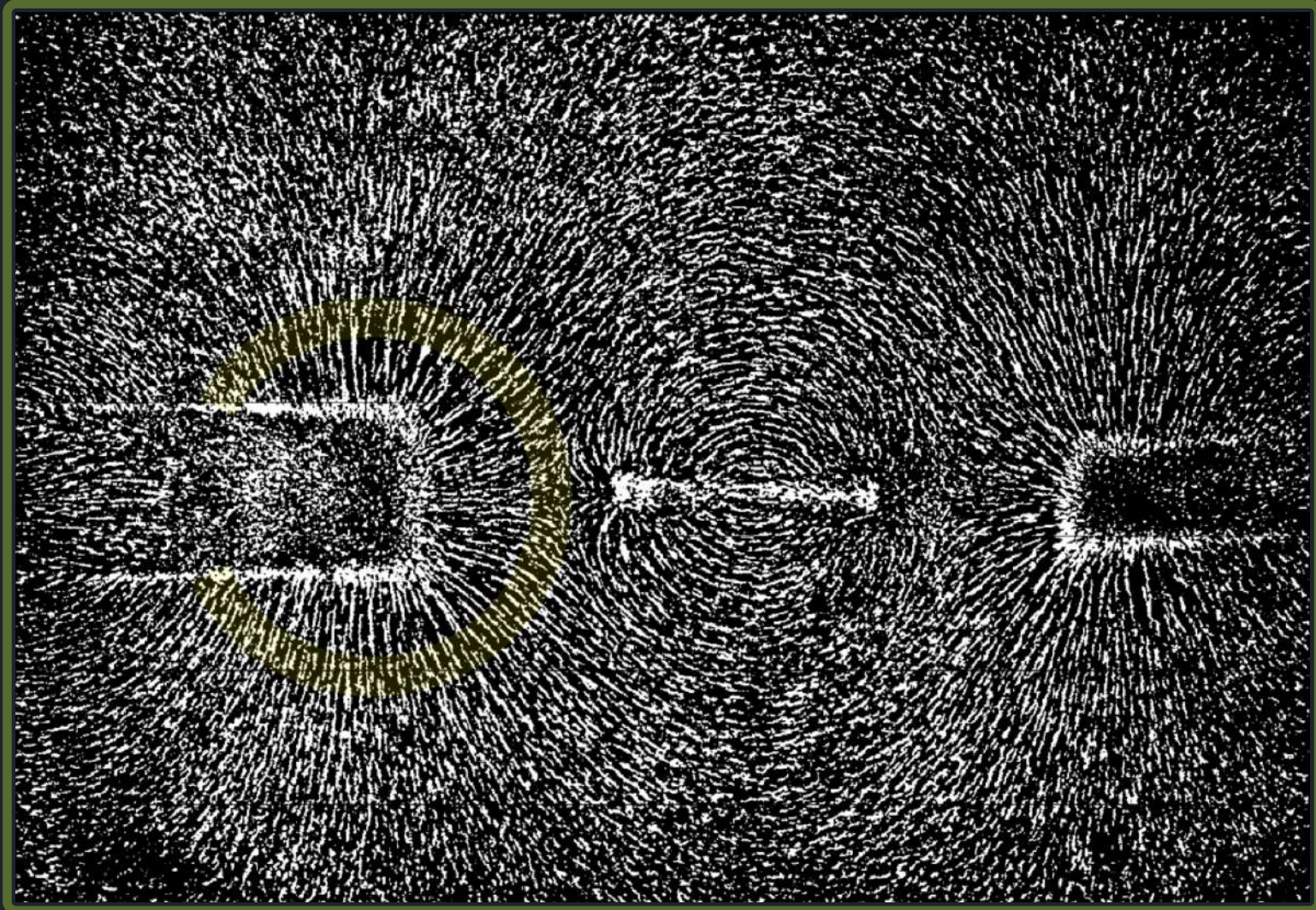

This revealed *magnetic flux lines*
sourced by the magnetic poles.

Hence the magnetic field B is encoded by how much flux F there is through any surface element $\Delta x^1 \times \Delta x^2$

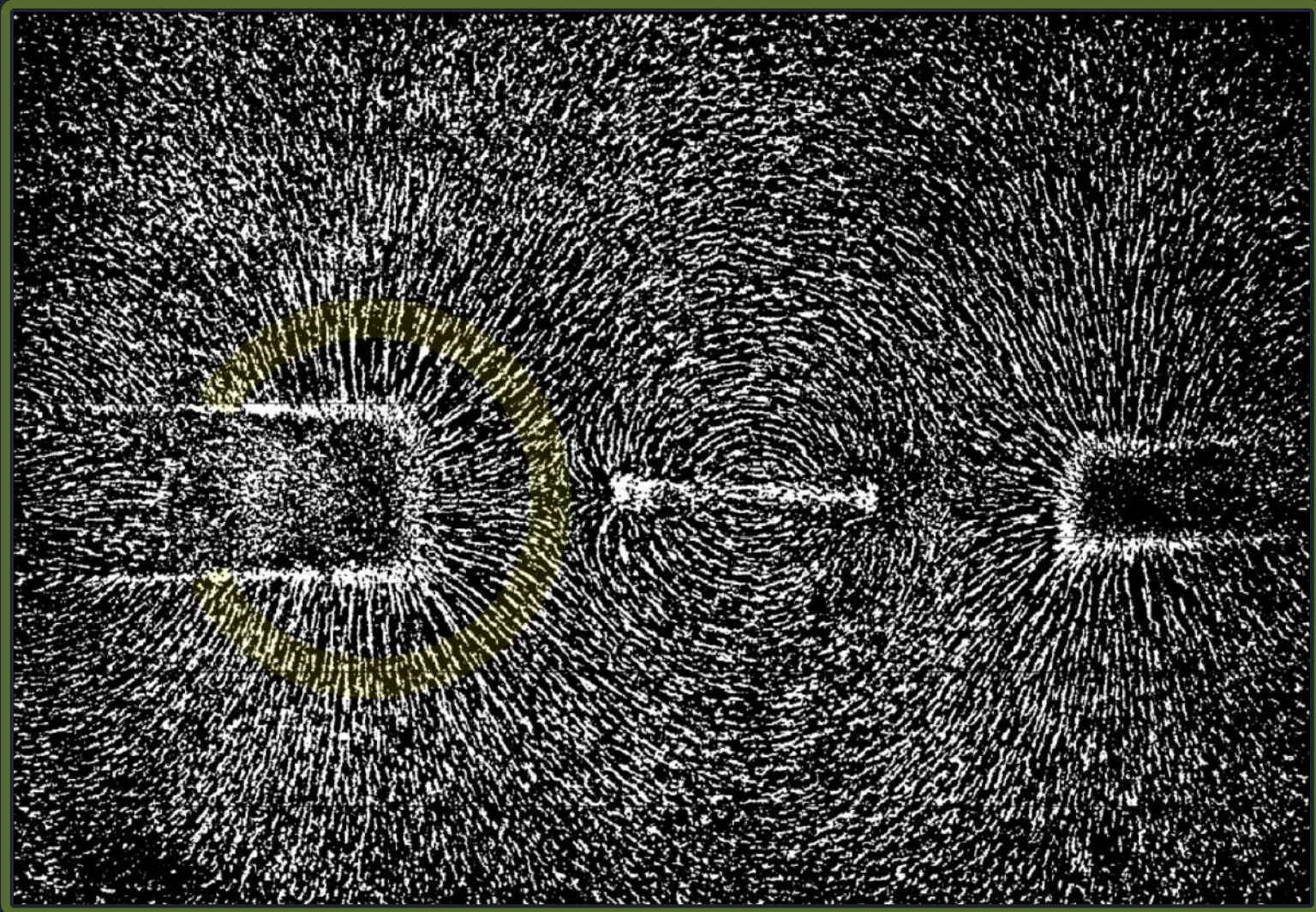

Hence the magnetic field B is encoded by how much flux F there is through any surface element $\Delta x^1 \times \Delta x^2$

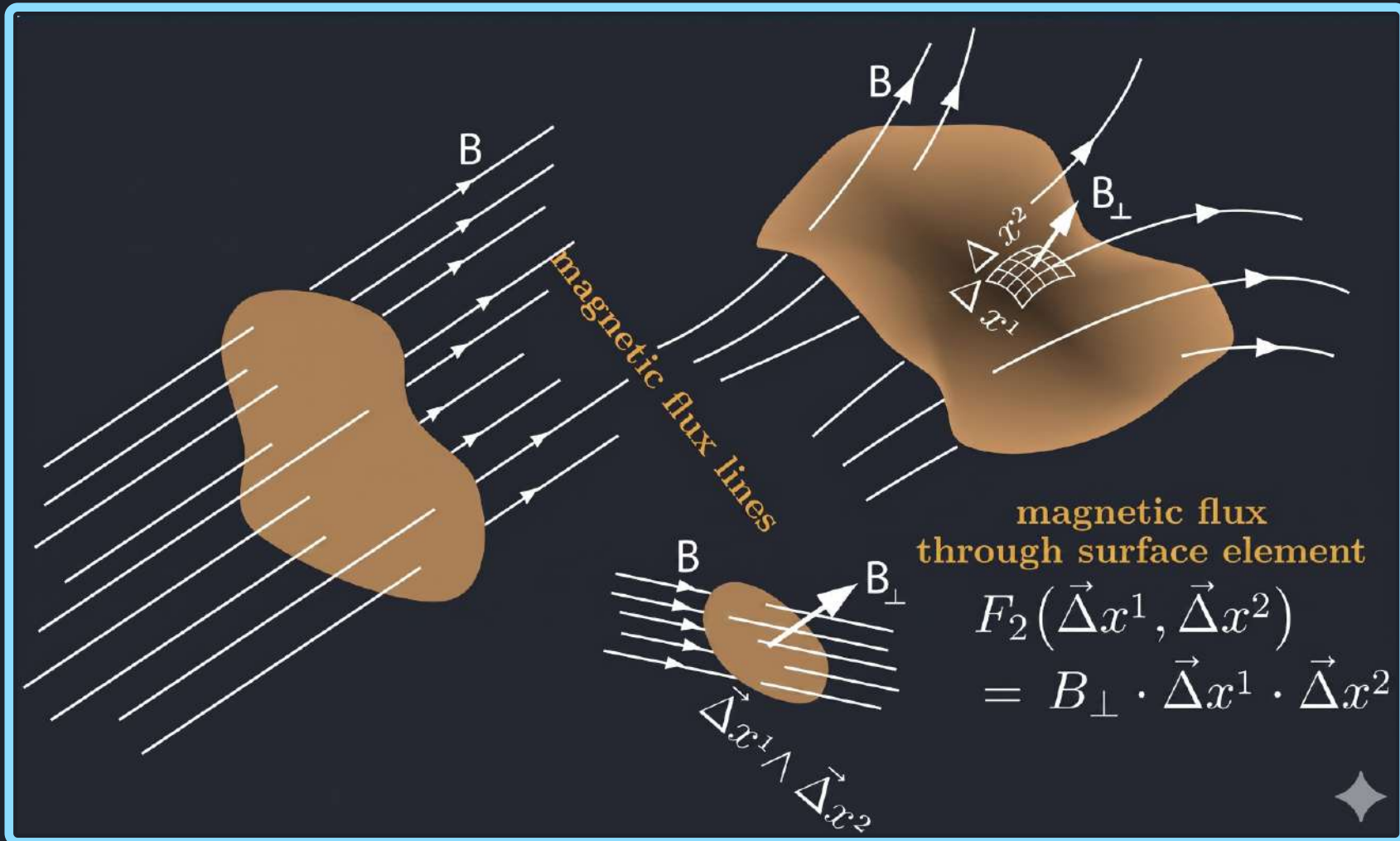

Hence the magnetic field B is encoded by how much flux F there is through any surface element $\Delta x^1 \times \Delta x^2$

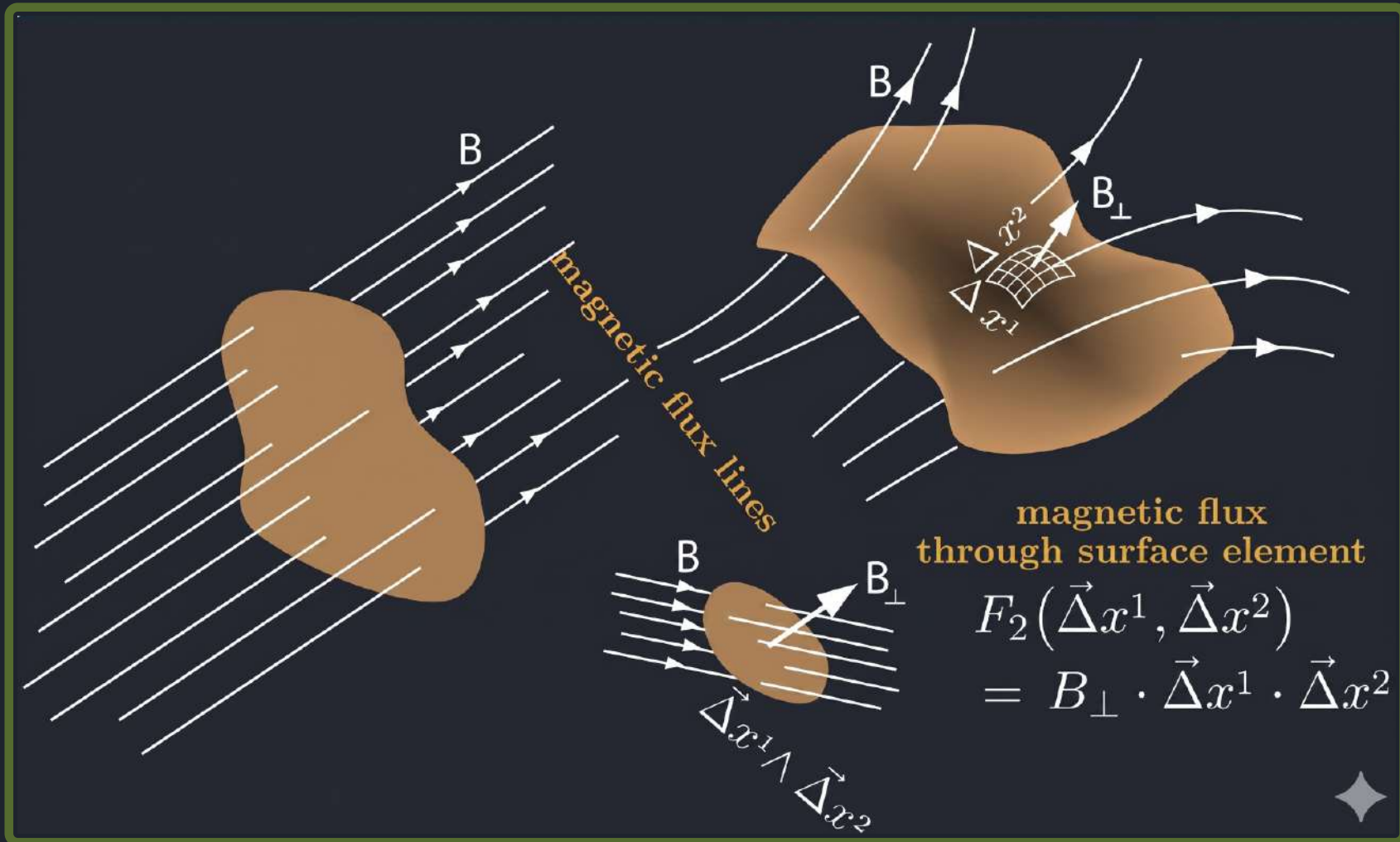

This assignment F_2 is now called a *differential 2-form*.

Hence the magnetic field B is encoded by how much flux F there is through any surface element $\Delta x^1 \times \Delta x^2$

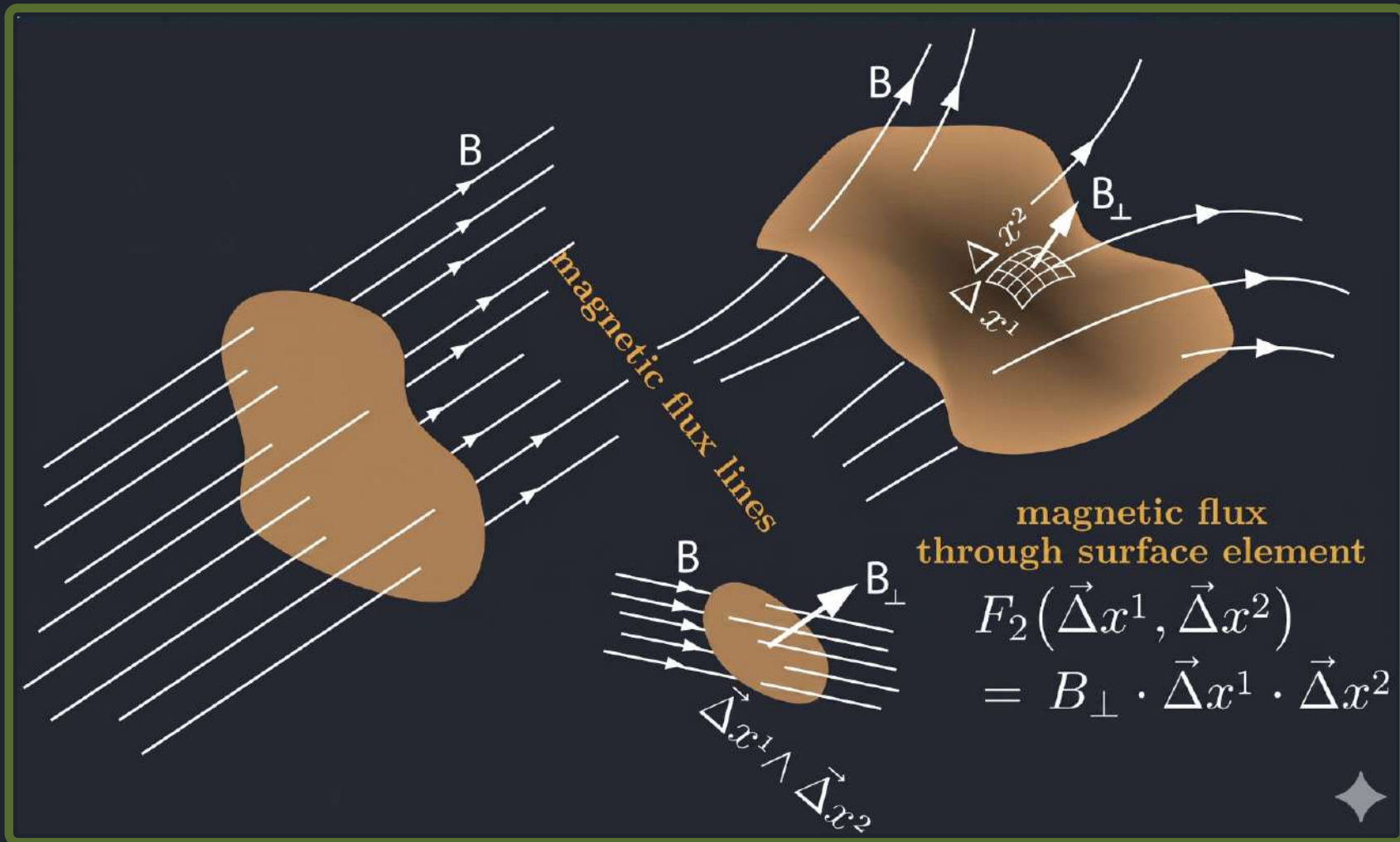

This assignment F_2 is now called a *differential 2-form*.

Magnetic flux density *diverges* at a (mono-)pole

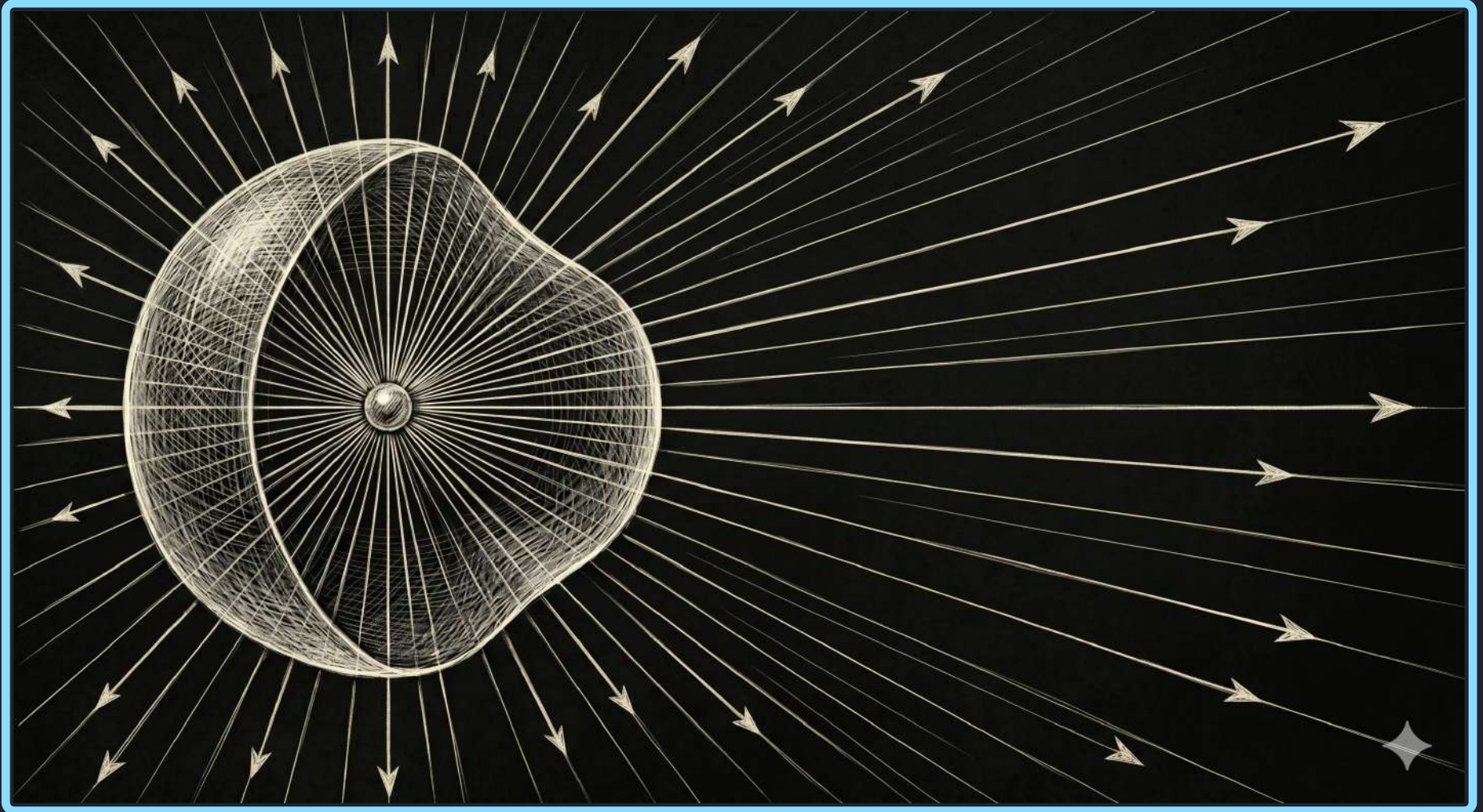

Magnetic flux density *diverges* at a (mono-)pole
and is *divergence free* elsewhere: “ $dF_2 = 0$ ”.

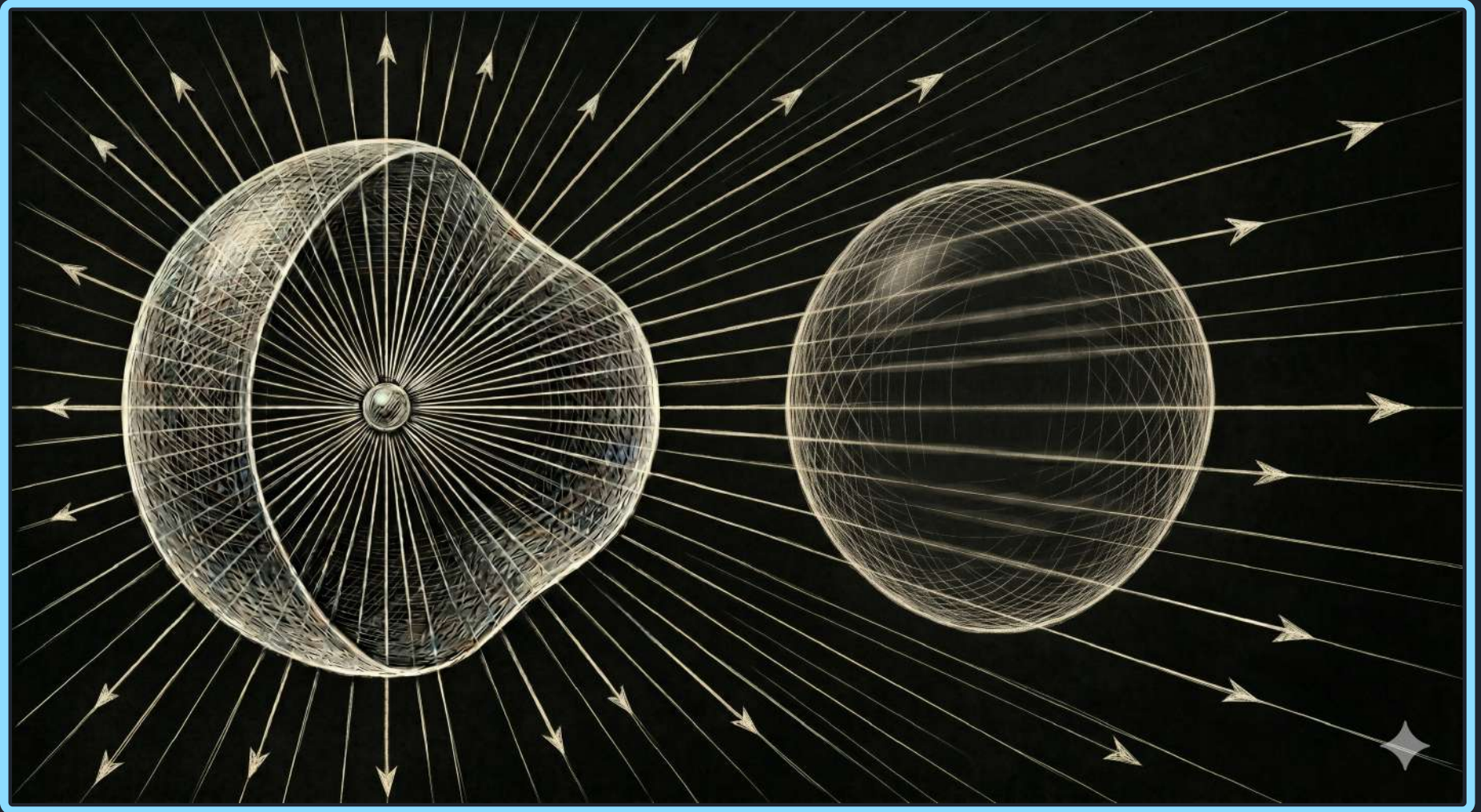

Magnetic flux density *diverges* at a (mono-)pole
and is *divergence free* elsewhere: “ $dF_2 = 0$ ”.

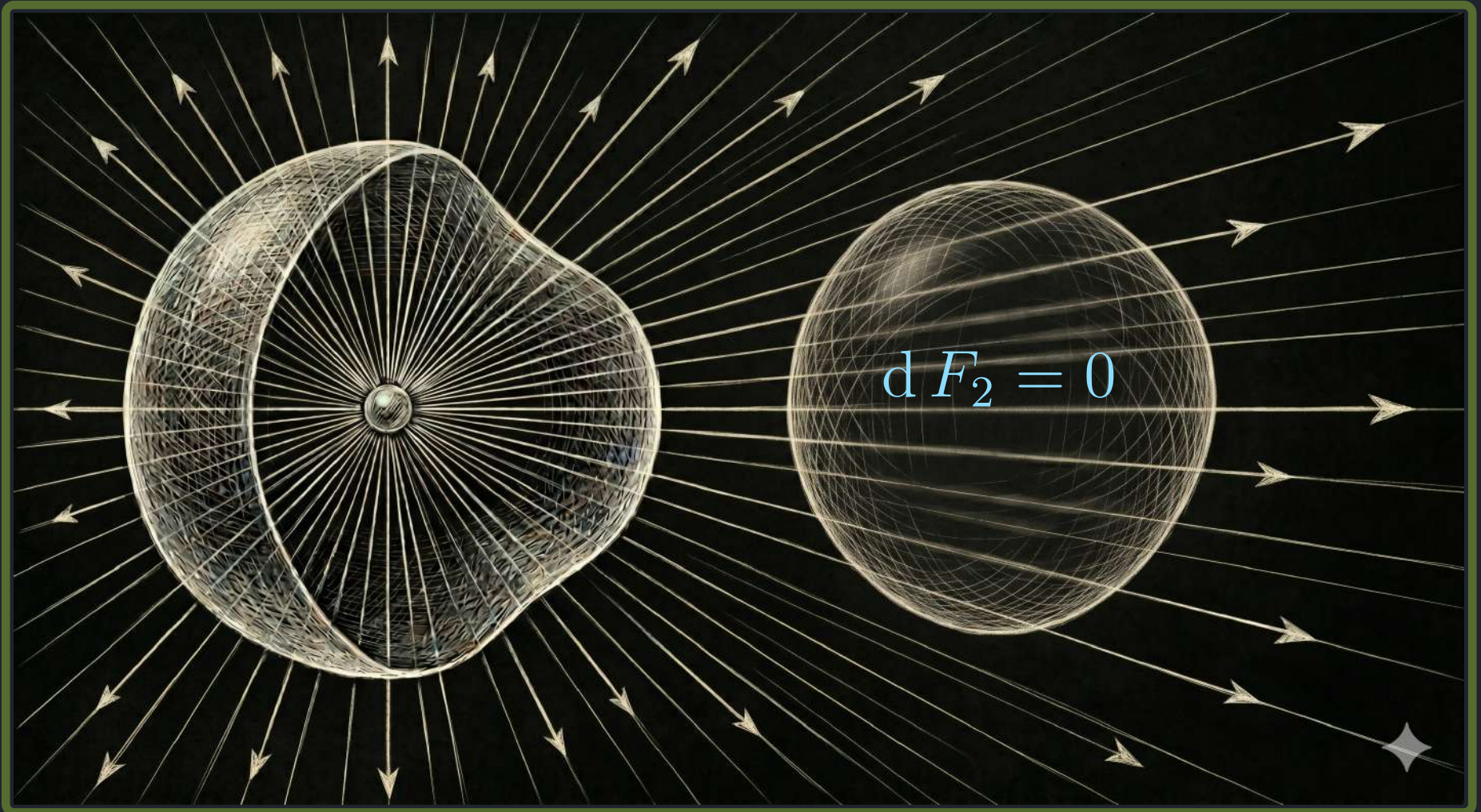

Magnetic flux density *diverges* at a (mono-)pole
and is *divergence free* elsewhere: “ $dF_2 = 0$ ”.



Magnetic flux density *diverges* at a (mono-)pole
and is *divergence free* elsewhere: “ $dF_2 = 0$ ”.

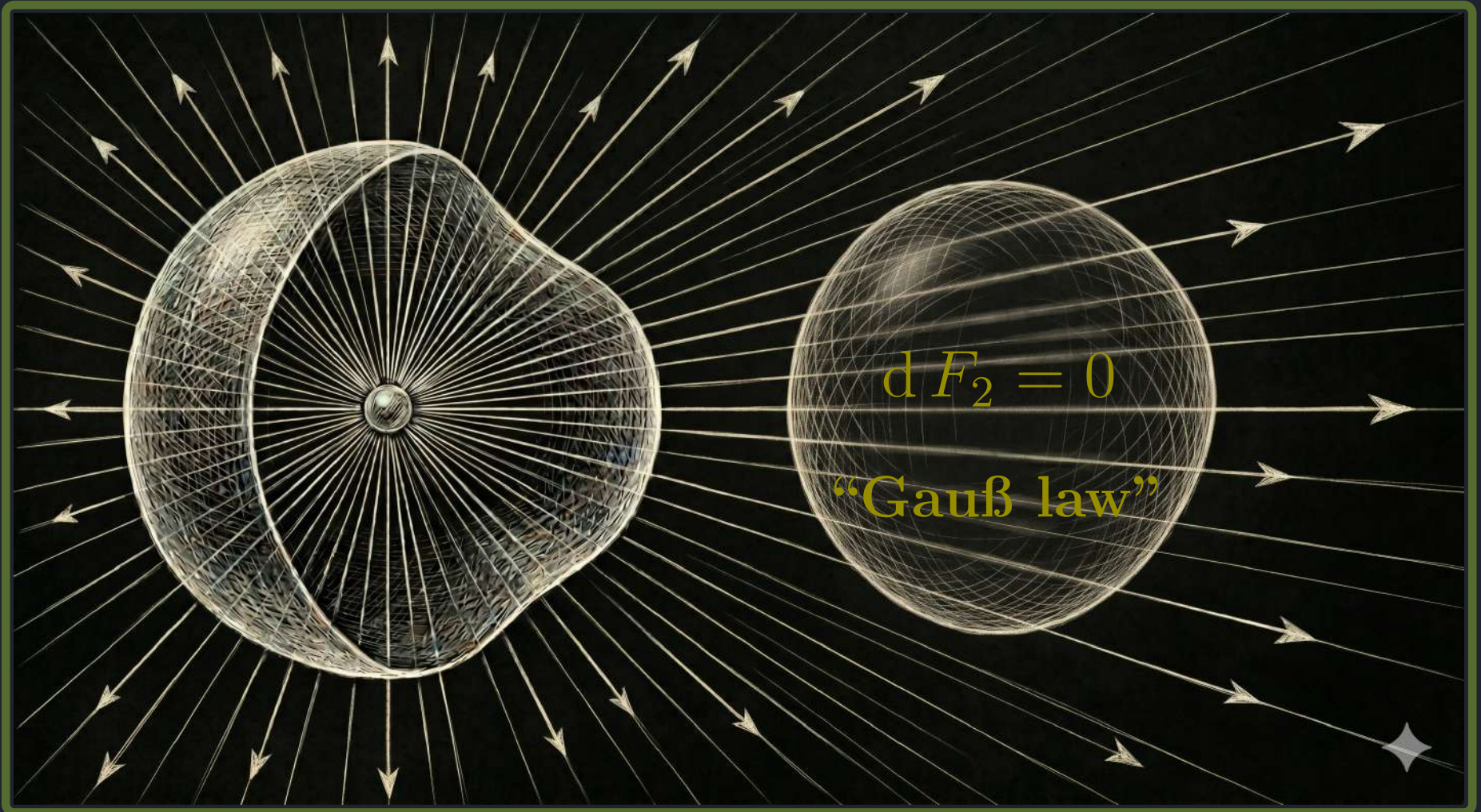

Magnetic flux density *diverges* at a (mono-)pole and is *divergence free* elsewhere: “ $dF_2 = 0$ ”.

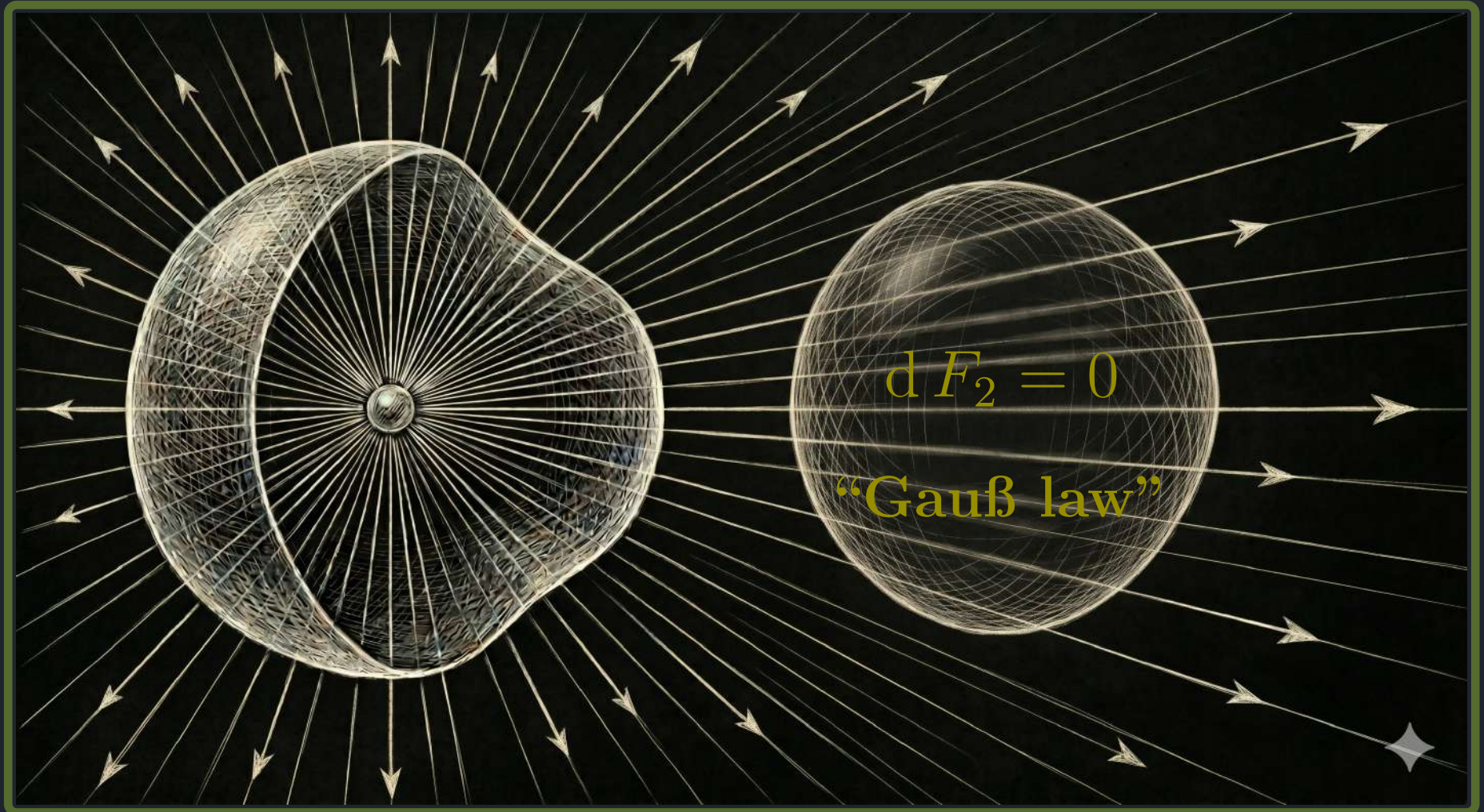

Otherwise, according to Faraday, the total flux through any sphere could take any value.

Magnetic flux density *diverges* at a (mono-)pole
and is *divergence free* elsewhere: “ $dF_2 = 0$ ”.

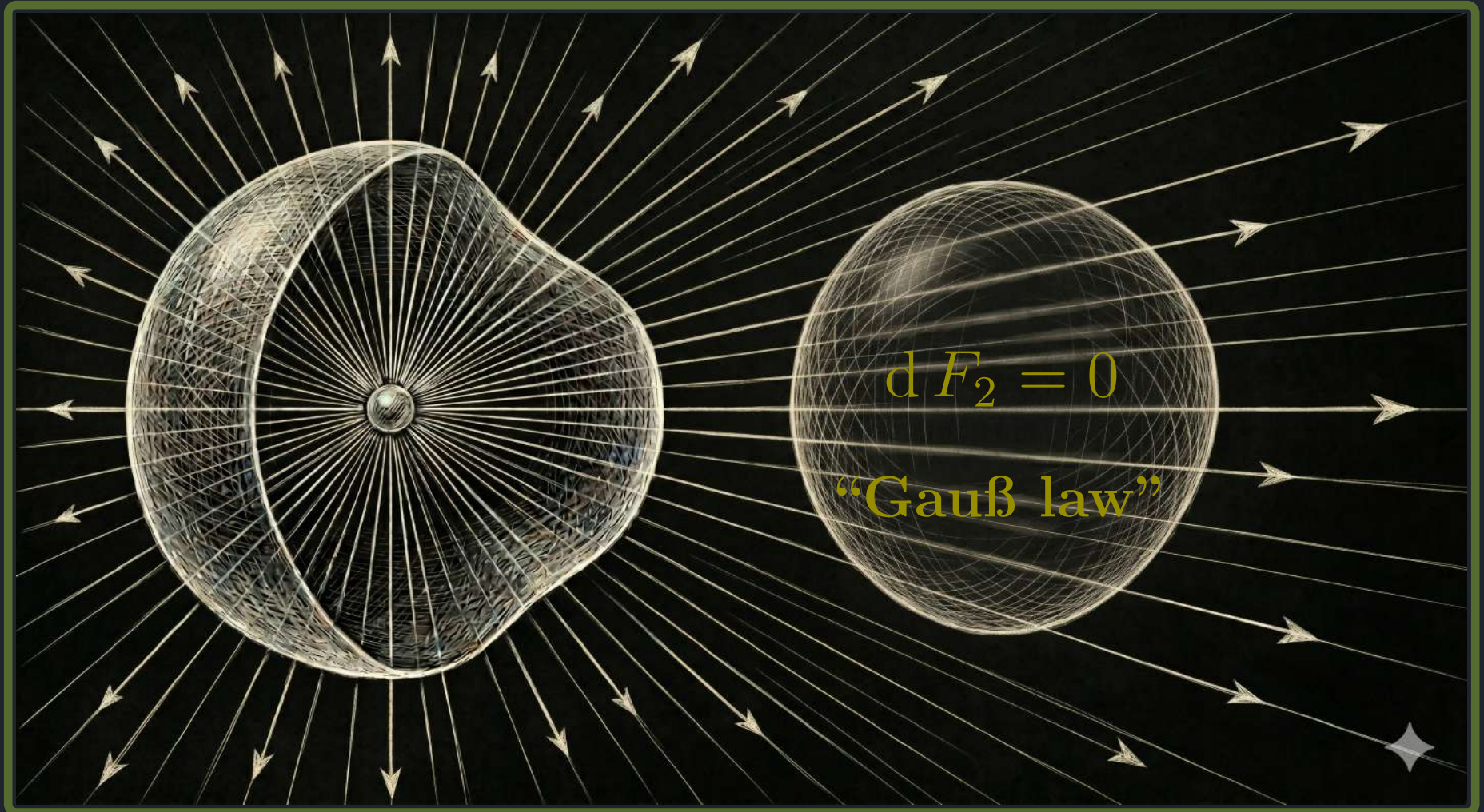

Otherwise, according to Faraday, the total flux
through any sphere could take any value.

In 1931 P.A.M Dirac noticed that this is in fact wrong.

In 1931 P.A.M Dirac noticed that this is in fact wrong.

Quantised Singularities in the Electromagnetic Field
By P. A. M. DIRAC, F.R.S., St. John's College, Cambridge.
(Received May 29, 1931.)

In 1931 P.A.M Dirac noticed that this is in fact wrong.

Quantised Singularities in the Electromagnetic Field
By P. A. M. DIRAC, F.R.S., St. John's College, Cambridge.
(Received May 29, 1931.)

Dirac: { Total magnetic flux through closed surfaces comes
in integer multiples of a unit *flux quantum*.

In 1931 P.A.M Dirac noticed that this is in fact wrong.

Quantised Singularities in the Electromagnetic Field
By P. A. M. DIRAC, F.R.S., St. John's College, Cambridge.
(Received May 29, 1931.)

Dirac: { Total magnetic flux through closed surfaces comes
in integer multiples of a unit *flux quantum*.

Since 1967 these flux quanta are experimentally observed:

In 1931 P.A.M Dirac noticed that this is in fact wrong.

Quantised Singularities in the Electromagnetic Field
By P. A. M. DIRAC, F.R.S., St. John's College, Cambridge.
(Received May 29, 1931.)

Dirac: { Total magnetic flux through closed surfaces comes
in integer multiples of a unit *flux quantum*.

Since 1967 these flux quanta are experimentally observed:

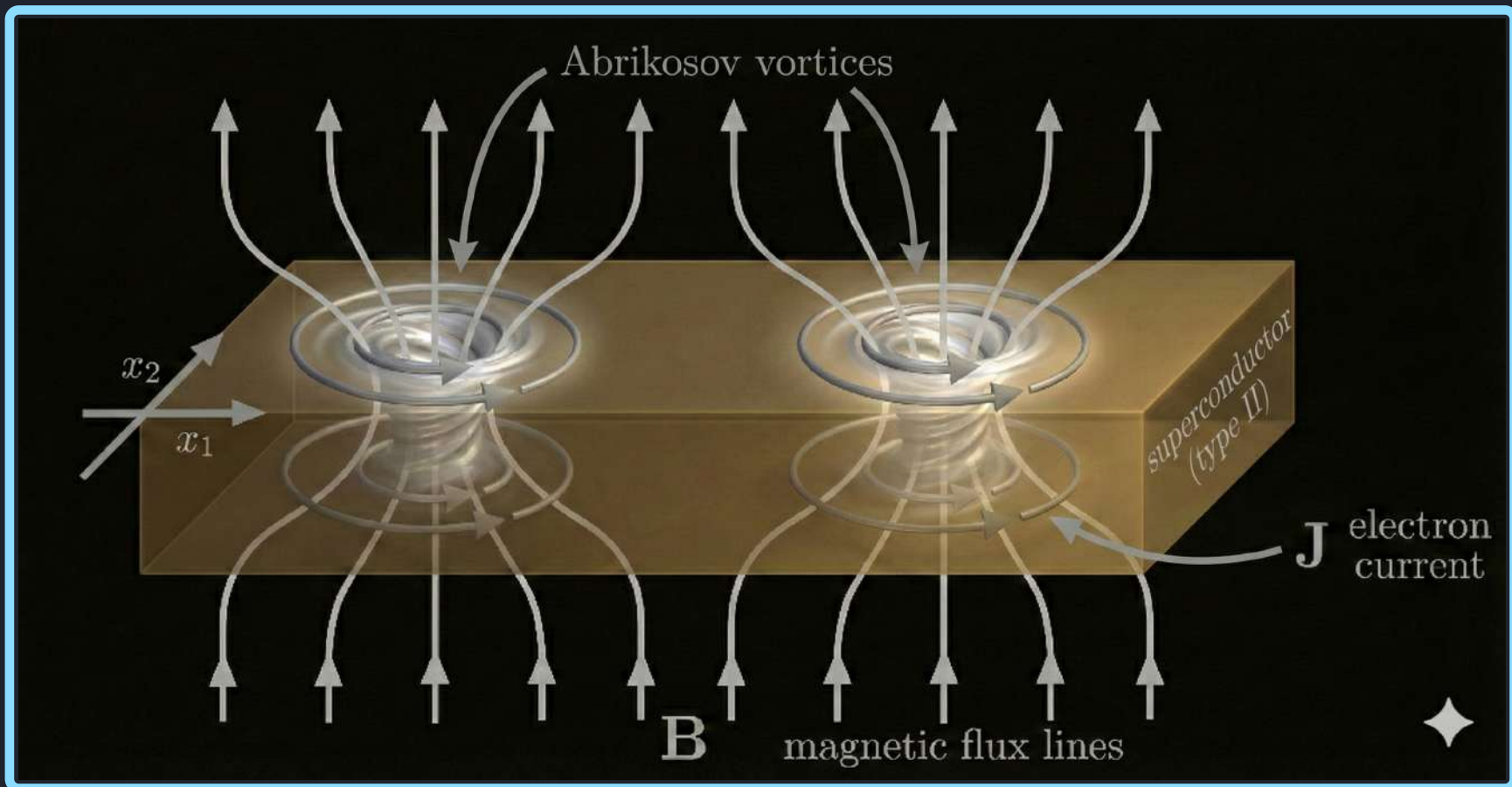

In 1931 P.A.M Dirac noticed that this is in fact wrong.

Quantised Singularities in the Electromagnetic Field
By P. A. M. DIRAC, F.R.S., St. John's College, Cambridge.
(Received May 29, 1931.)

Dirac: { Total magnetic flux through closed surfaces comes
in integer multiples of a unit *flux quantum*.

Since 1967 these flux quanta are experimentally observed:

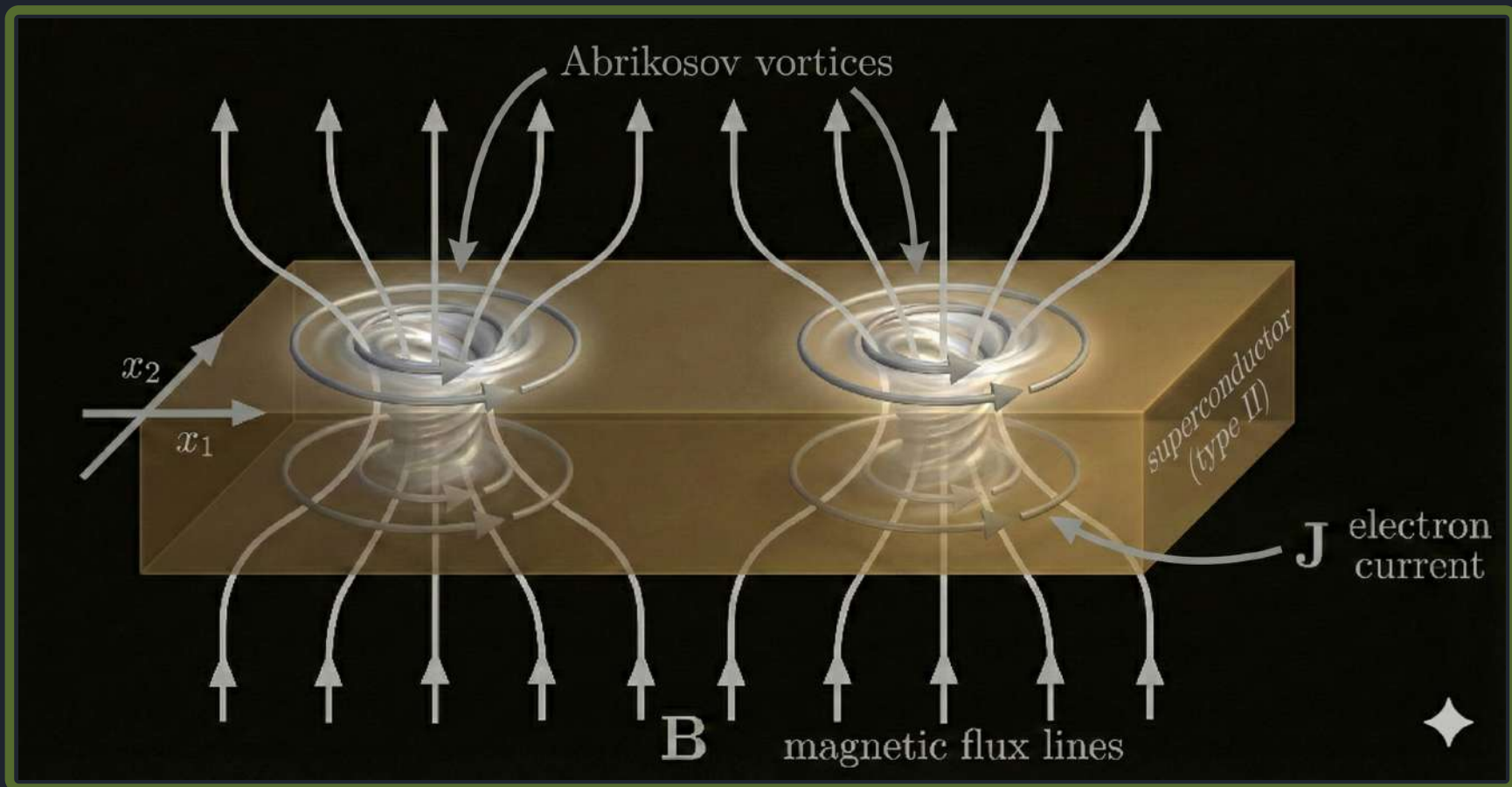

In 1931 P.A.M Dirac noticed that this is in fact wrong.

Quantised Singularities in the Electromagnetic Field
By P. A. M. DIRAC, F.R.S., St. John's College, Cambridge.
(Received May 29, 1931.)

Dirac: { Total magnetic flux through closed surfaces comes
in integer multiples of a unit *flux quantum*.

In 1931 P.A.M Dirac noticed that this is in fact wrong.

Quantised Singularities in the Electromagnetic Field
By P. A. M. DIRAC, F.R.S., St. John's College, Cambridge.
(Received May 29, 1931.)

Dirac: { Total magnetic flux through closed surfaces comes
in integer multiples of a unit *flux quantum*.

But this is a subtle non-perturbative constraint:

Locally the flux density is arbitrary, but
globally it integrates to an integer!

In 1931 P.A.M Dirac noticed that this is in fact wrong.

Quantised Singularities in the Electromagnetic Field
By P. A. M. DIRAC, F.R.S., St. John's College, Cambridge.
(Received May 29, 1931.)

Dirac: { Total magnetic flux through closed surfaces comes
in integer multiples of a unit *flux quantum*.

But this is a subtle non-perturbative constraint:

Locally the flux density is arbitrary, but
globally it integrates to an integer!

akin to knots:
locally free,
globally fixed

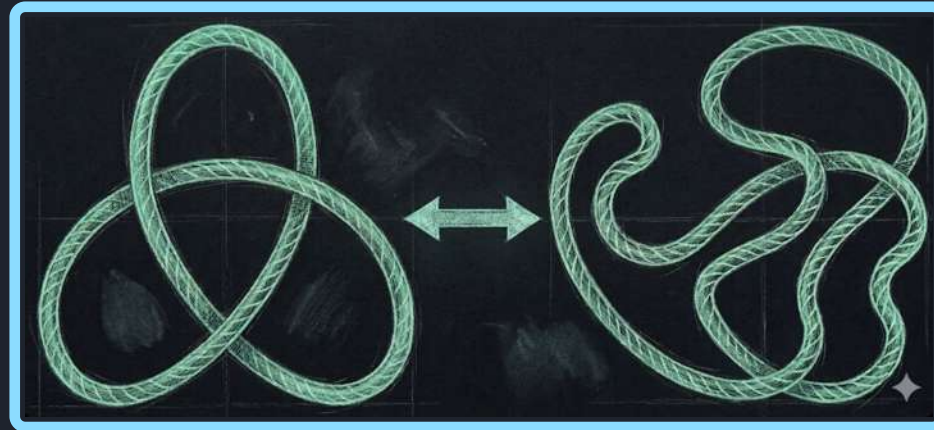

In 1931 P.A.M Dirac noticed that this is in fact wrong.

Quantised Singularities in the Electromagnetic Field
By P. A. M. DIRAC, F.R.S., St. John's College, Cambridge.
(Received May 29, 1931.)

Dirac: { Total magnetic flux through closed surfaces comes
in integer multiples of a unit *flux quantum*.

But this is a subtle non-perturbative constraint:

Locally the flux density is arbitrary, but
globally it integrates to an integer!

akin to knots:
locally free,
globally fixed

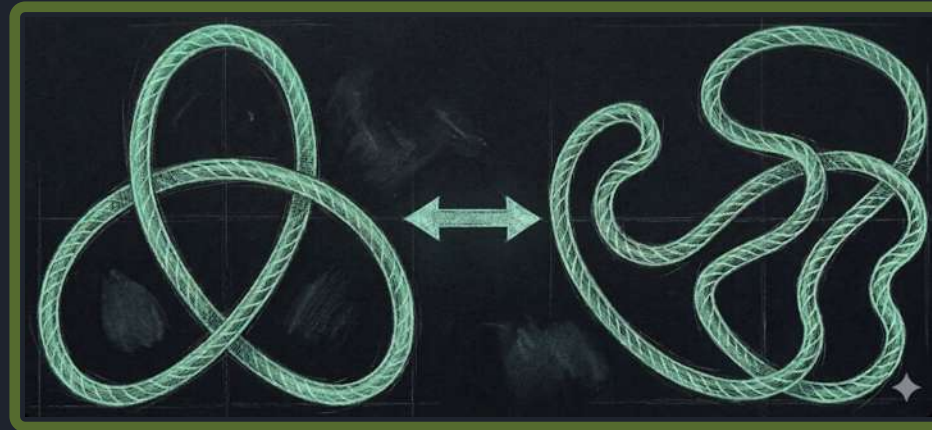

Mathematical solution:

Total flux comes from maps to a *classifying space*,
which encodes the *topology* (knotting) of the field.

In 1931 P.A.M Dirac noticed that this is in fact wrong.

Quantised Singularities in the Electromagnetic Field
By P. A. M. DIRAC, F.R.S., St. John's College, Cambridge.
(Received May 29, 1931.)

Dirac: { Total magnetic flux through closed surfaces comes
in integer multiples of a unit *flux quantum*.

But this is a subtle non-perturbative constraint:

Locally the flux density is arbitrary, but
globally it integrates to an integer!

akin to knots:
locally free,
globally fixed

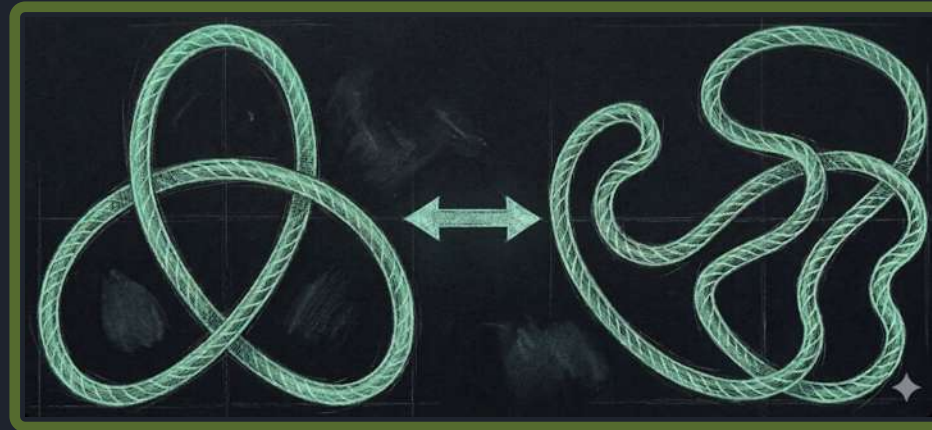

Mathematical solution:

Total flux comes from maps to a *classifying space*,
which encodes the *topology* (knotting) of the field.

A model for the classifying space
of the ordinary magnetic field.

Consider *Complex Projective 2-Space*

$$\mathbb{C}P^2 := \left\{ \text{complex lines in } \mathbb{C}^3 \right\}$$

A model for the classifying space
of the ordinary magnetic field.

Consider *Complex Projective 2-Space*

$$\mathbb{C}P^2 := \left\{ \text{complex lines in } \mathbb{C}^3 \right\}$$

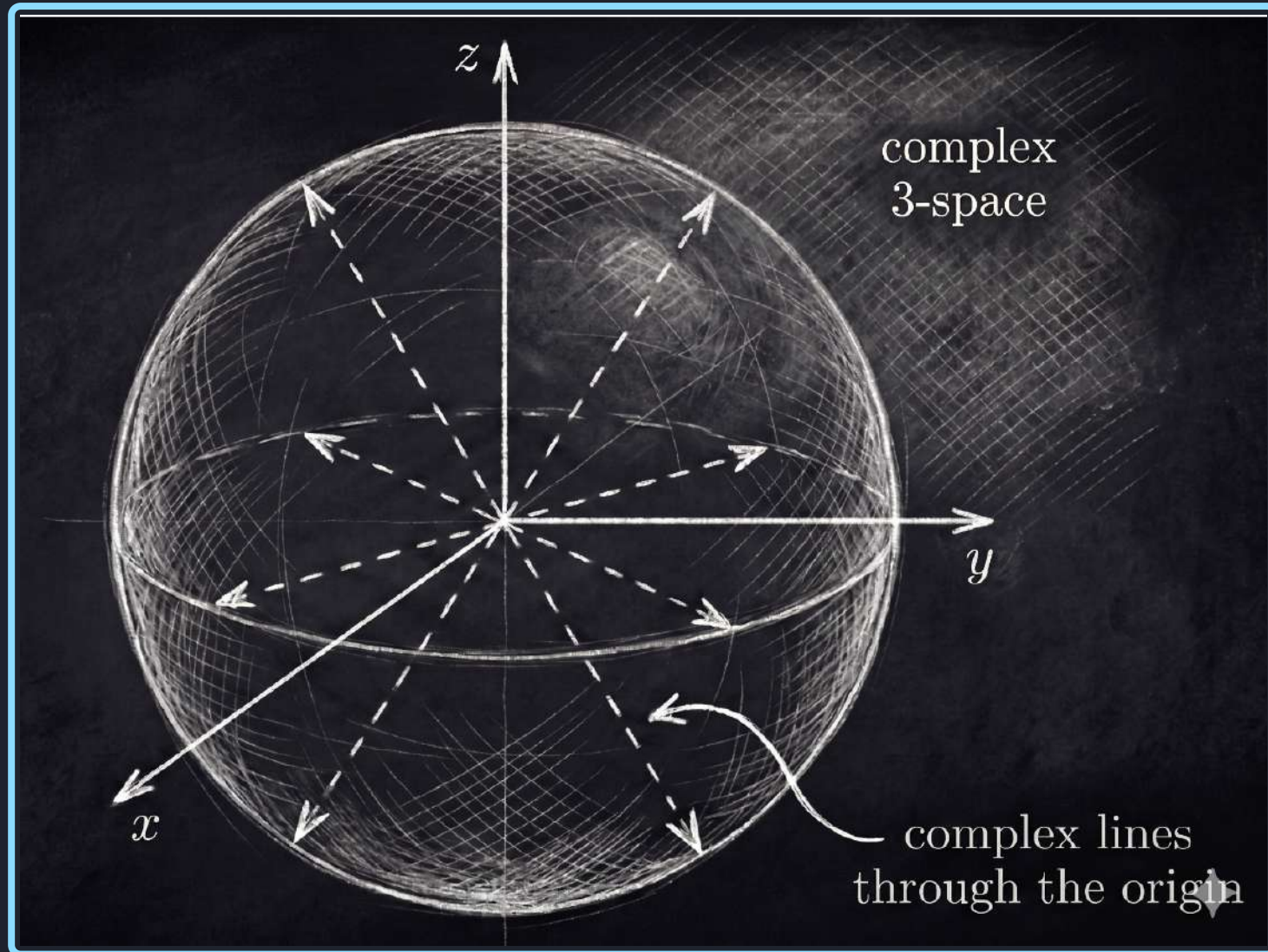

Consider *Complex Projective 2-Space*

$$\mathbb{C}P^2 := \left\{ \text{complex lines in } \mathbb{C}^3 \right\}$$

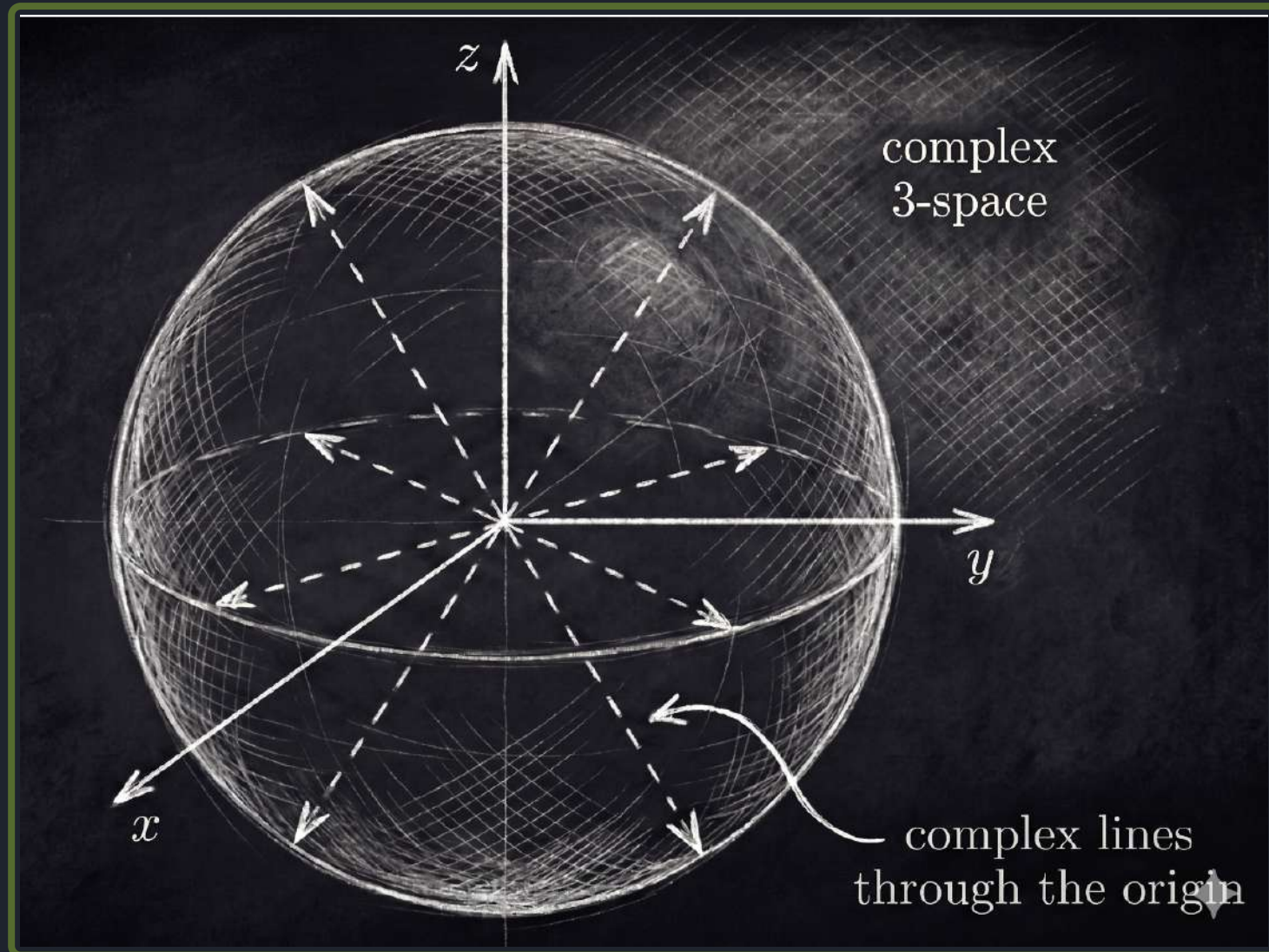

Fact: This carries a *universal flux density* f_2 whose total flux through any 2-sphere is an integer.

Consider *Complex Projective 2-Space*

$$\mathbb{C}P^2 := \left\{ \text{complex lines in } \mathbb{C}^3 \right\}$$

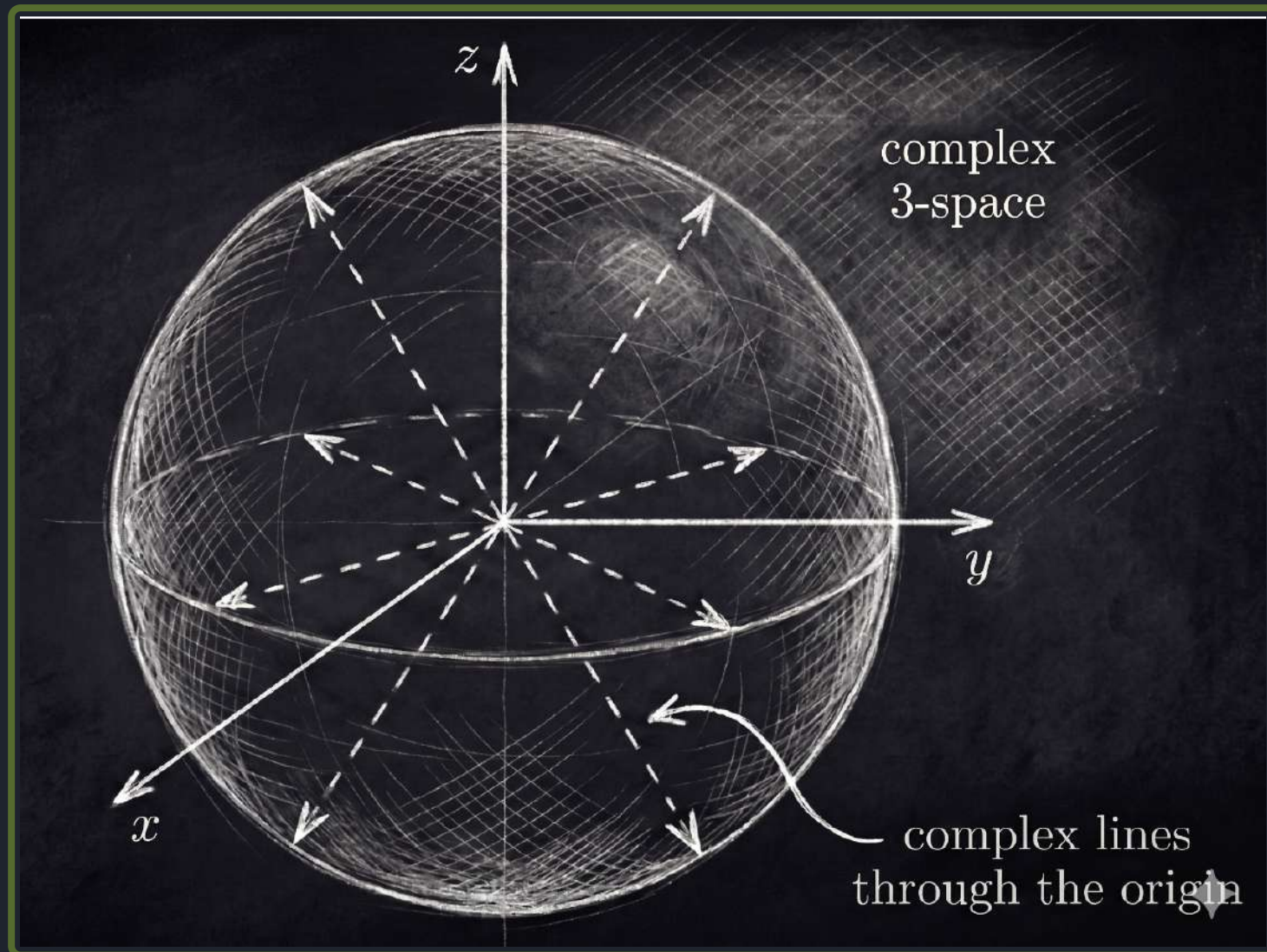

Fact: This carries a *universal flux density* f_2 whose total flux through any 2-sphere is an integer.

Now, Dirac Flux Quantization says, roughly, that the magnetic field involves a *classifying map* χ

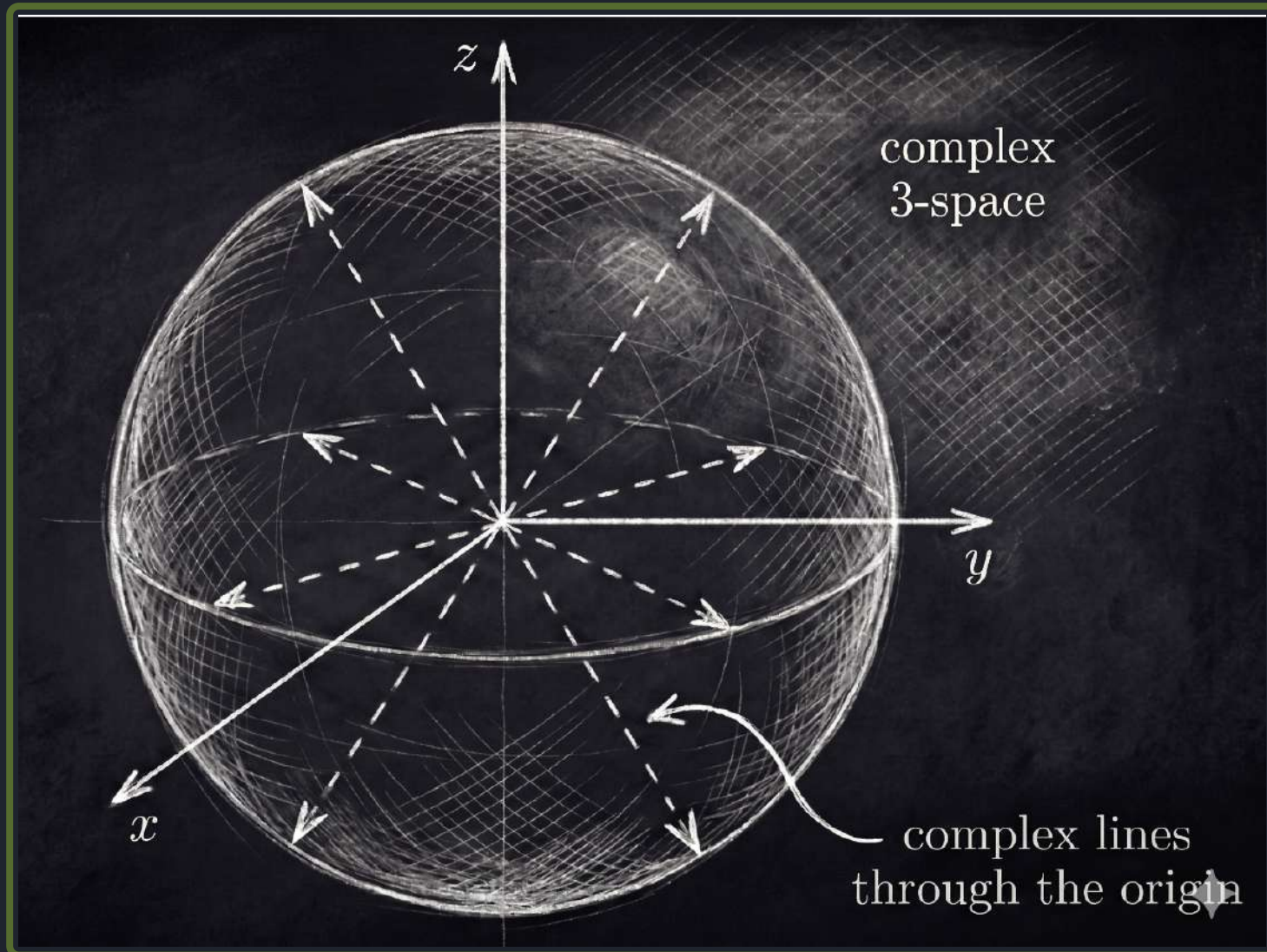

Now, Dirac Flux Quantization says, roughly, that the magnetic field involves a *classifying map* χ

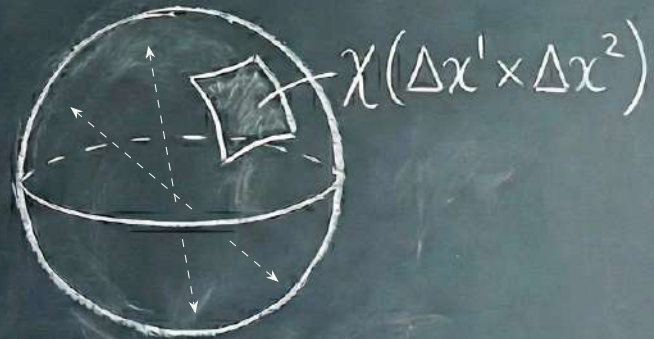
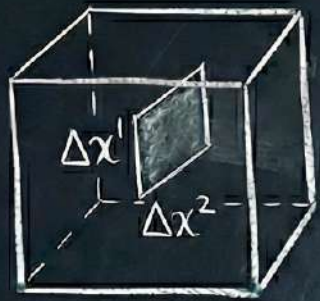

$$X^3 \xrightarrow{\chi} \mathbb{C}P^2$$

$$F_2 : \Delta x^1 \times \Delta x^2 \mapsto \chi(\Delta x^1 \times \Delta x^2) \mapsto \underbrace{f_2(\chi(\Delta x^1 \times \Delta x^2))}$$

$$F_2 = \chi^* f_2$$

Now, Dirac Flux Quantization says, roughly, that the magnetic field involves a *classifying map* χ

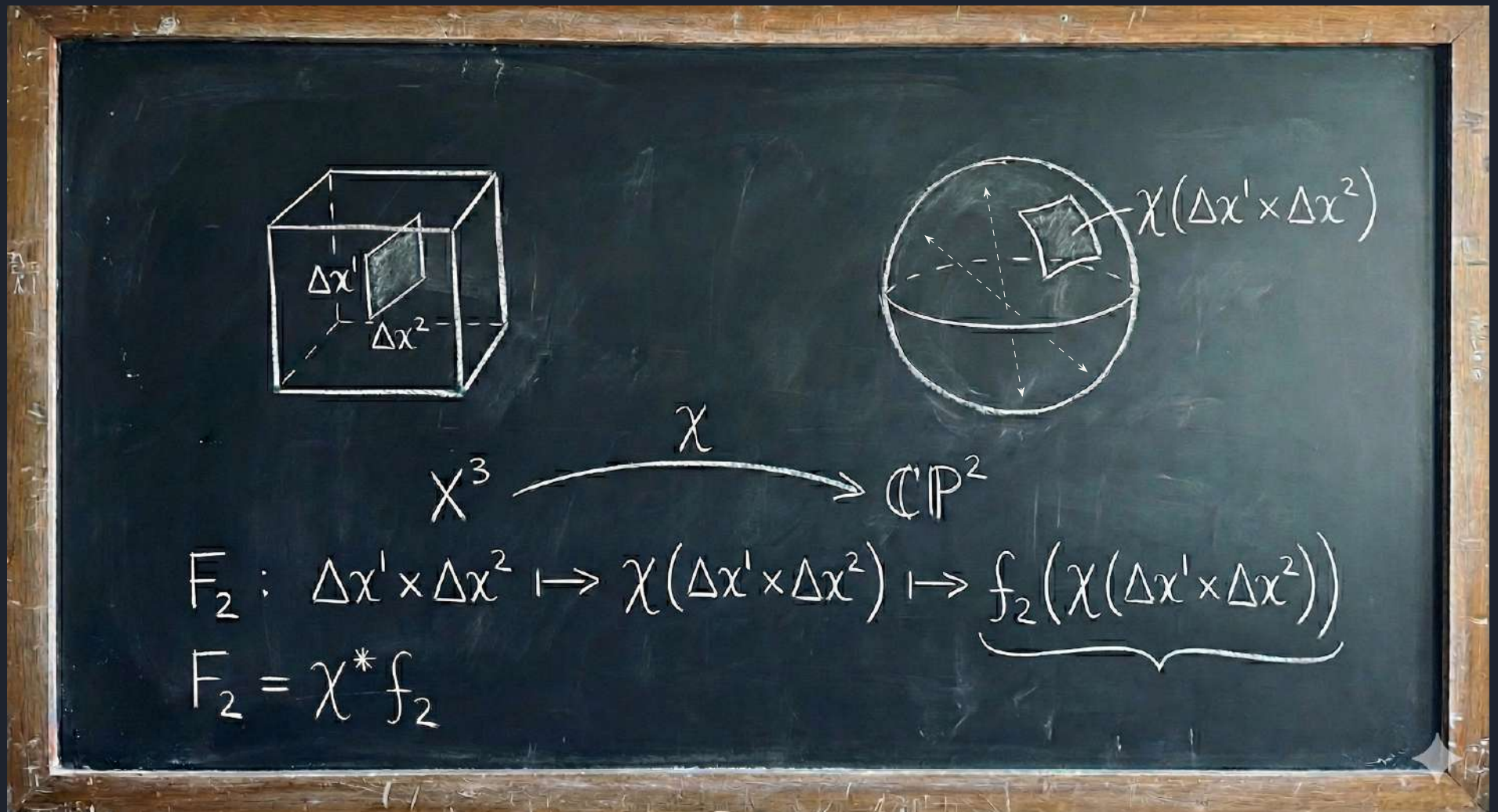

under which the flux density F_2 comes from the universal flux density f_2 .

Now, Dirac Flux Quantization says, roughly, that the magnetic field involves a *classifying map* χ

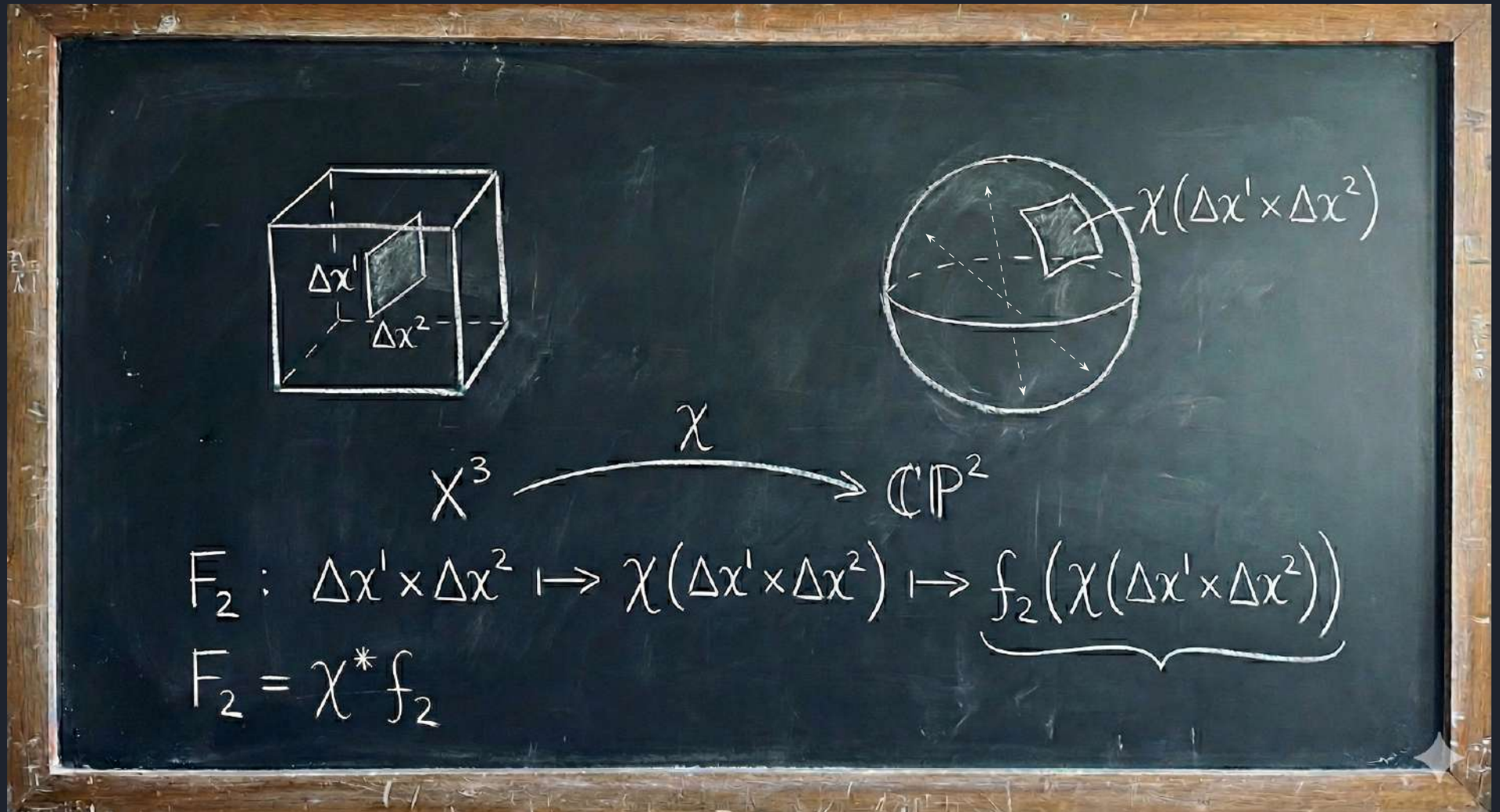

under which the flux density F_2 comes from the universal flux density f_2 .

This is the modern formulation of the electromagnetic field:

Flux densities F_2 with charge classifiers χ and compatibility $\chi \xrightarrow{\hat{A}} F_2$.

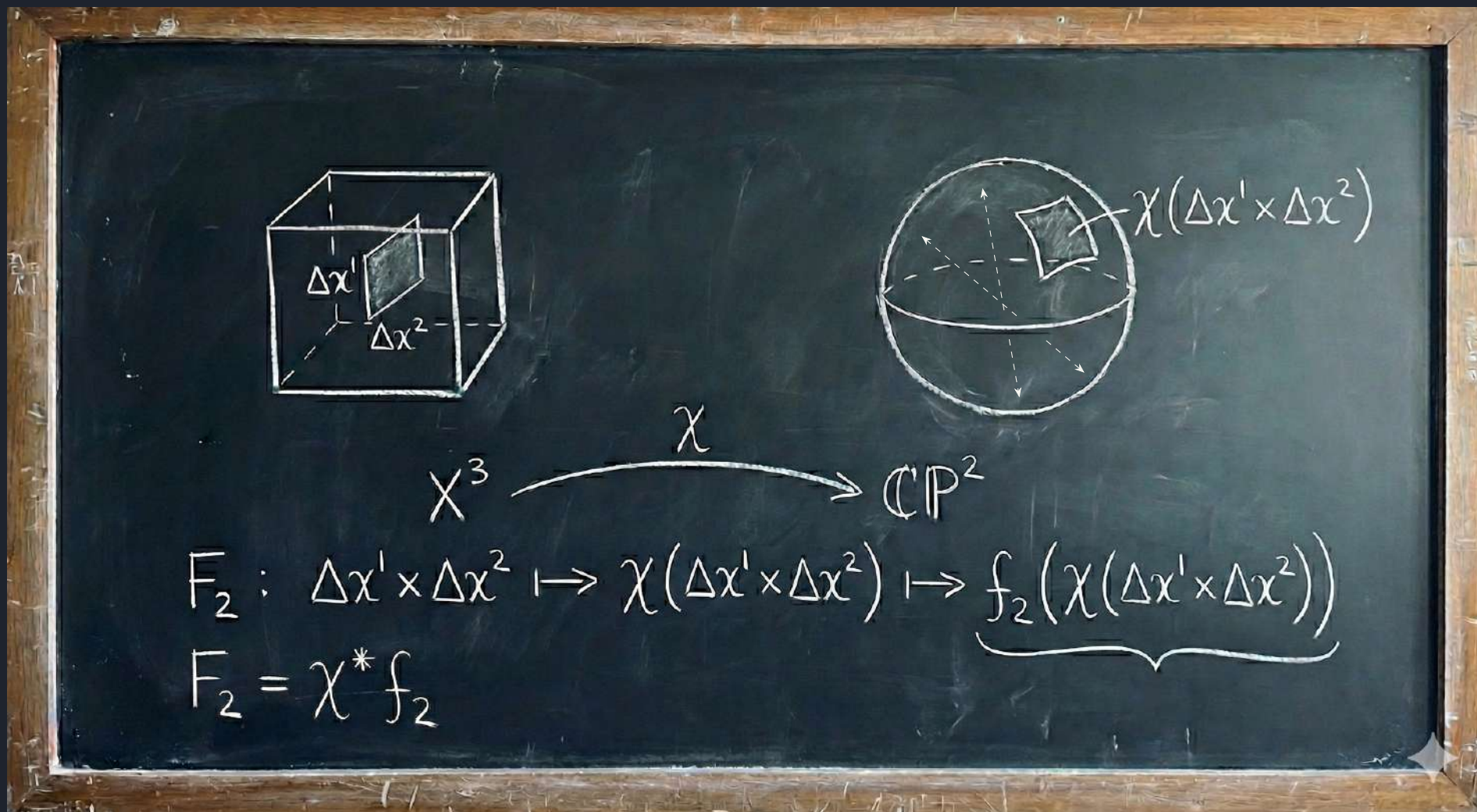

This is the modern formulation of the electromagnetic field:

Flux densities F_2 with charge classifiers χ and compatibility $\chi \xrightarrow{\hat{A}} F_2$.

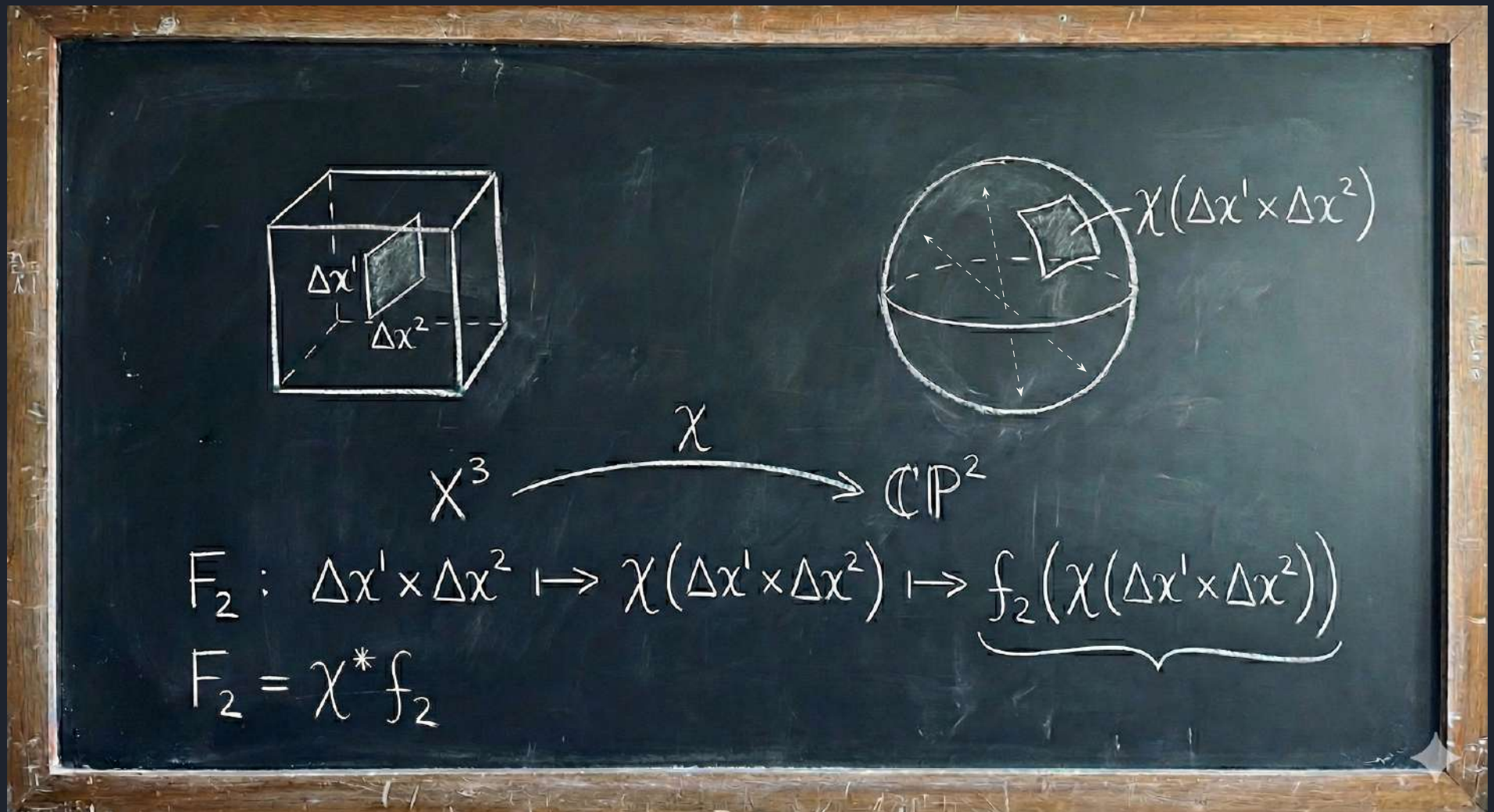

So the question is: What is the corresponding deformed effective description of surplus FQH flux??

This is the modern formulation of the electromagnetic field:

Flux densities F_2 with charge classifiers χ and compatibility $\chi \xrightarrow{\hat{A}} F_2$.

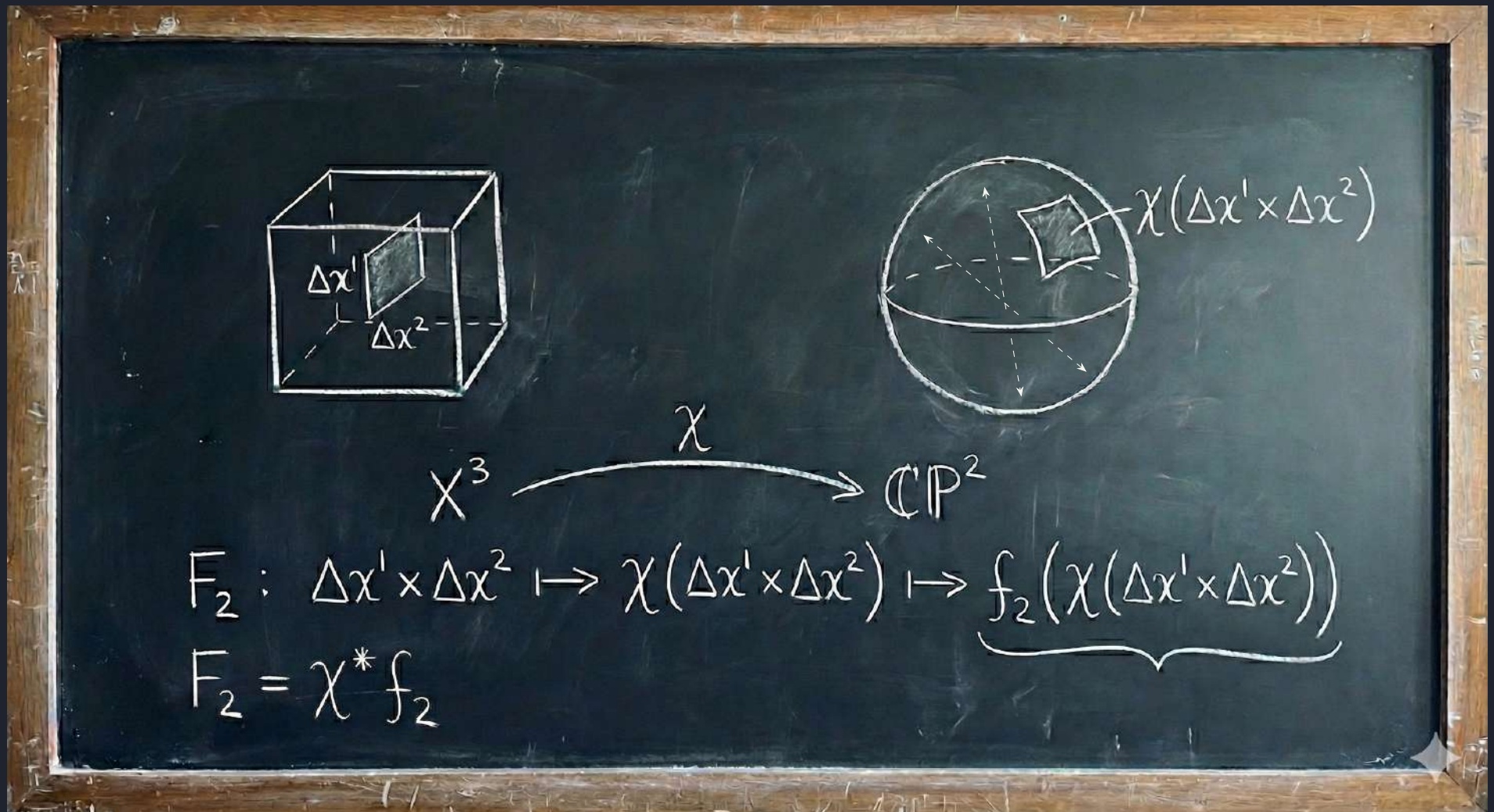

So the question is: What is the corresponding deformed effective description of surplus FQH flux??

Theorem: For surplus FQH flux this classifying space gets deformed to $\mathbb{C}P^1 \simeq S^2$

Theorem: For surplus FQH flux this classifying space gets deformed to $\mathbb{C}P^1 \simeq S^2$

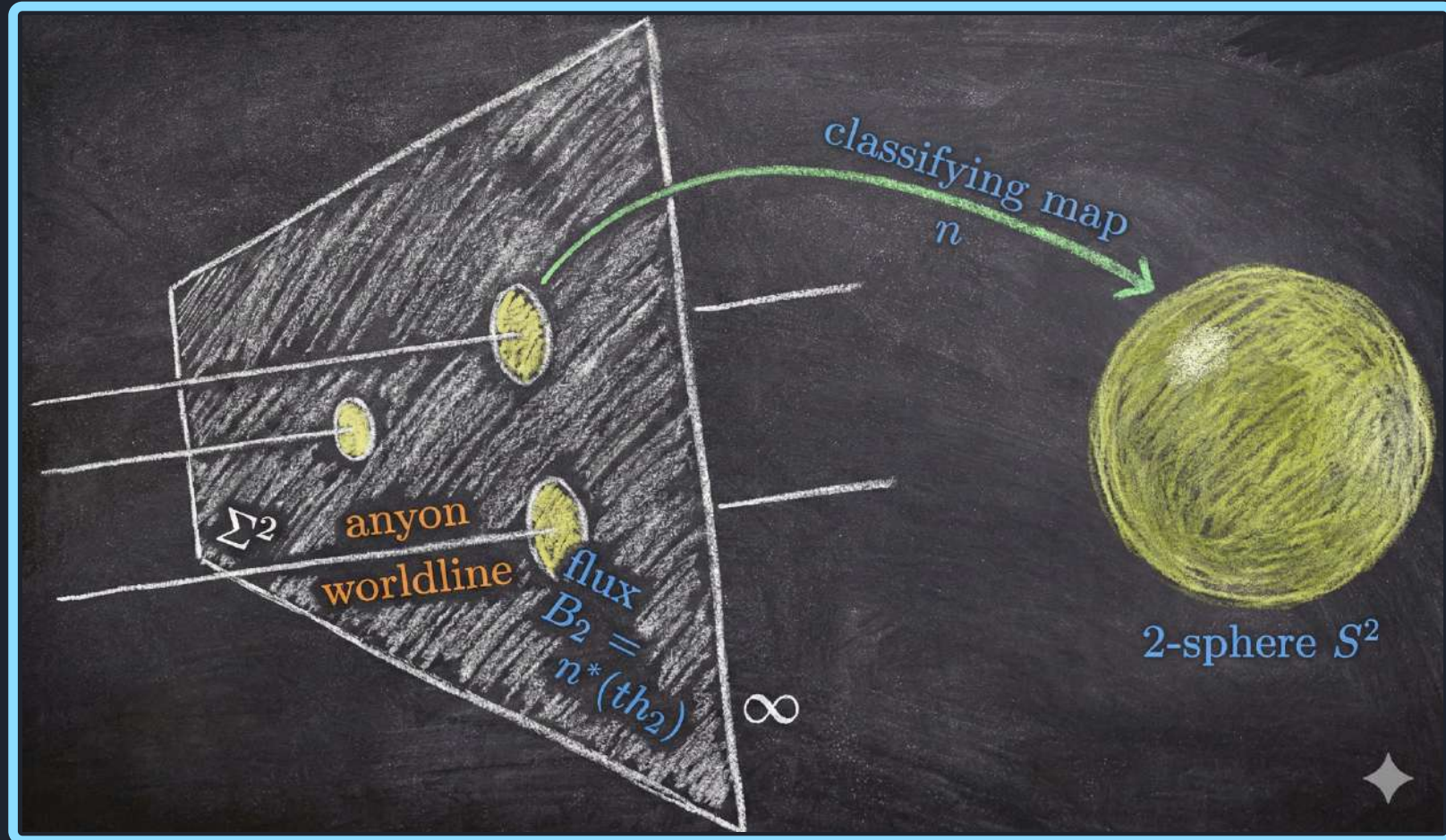

Theorem: For surplus FQH flux this classifying space gets deformed to $\mathbb{C}P^1 \simeq S^2$

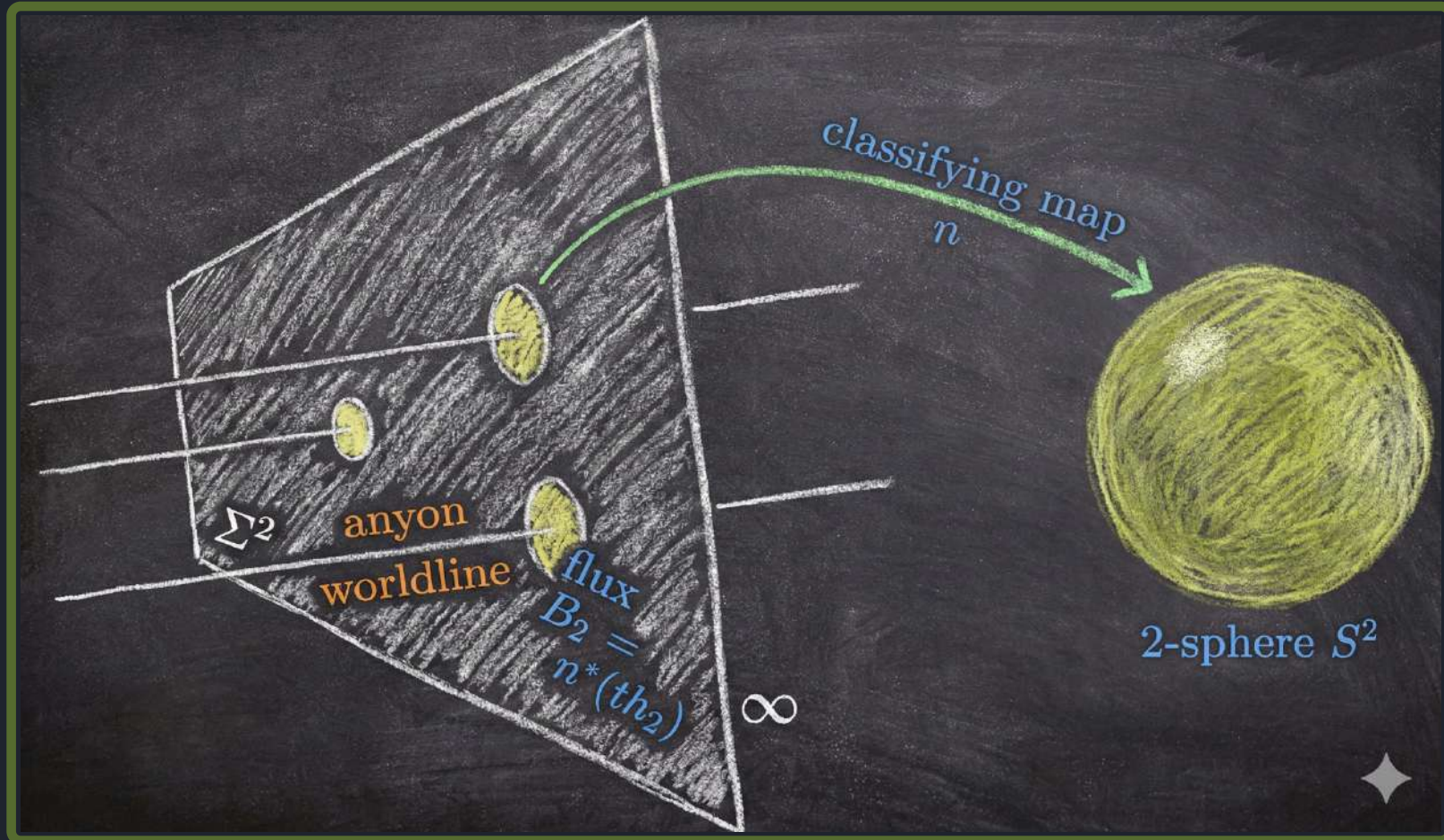

Surplus flux quanta get mapped around the 2-sphere and their worldlines exhibit anyon braiding phases!

Theorem: For surplus FQH flux this classifying space gets deformed to $\mathbb{C}P^1 \simeq S^2$

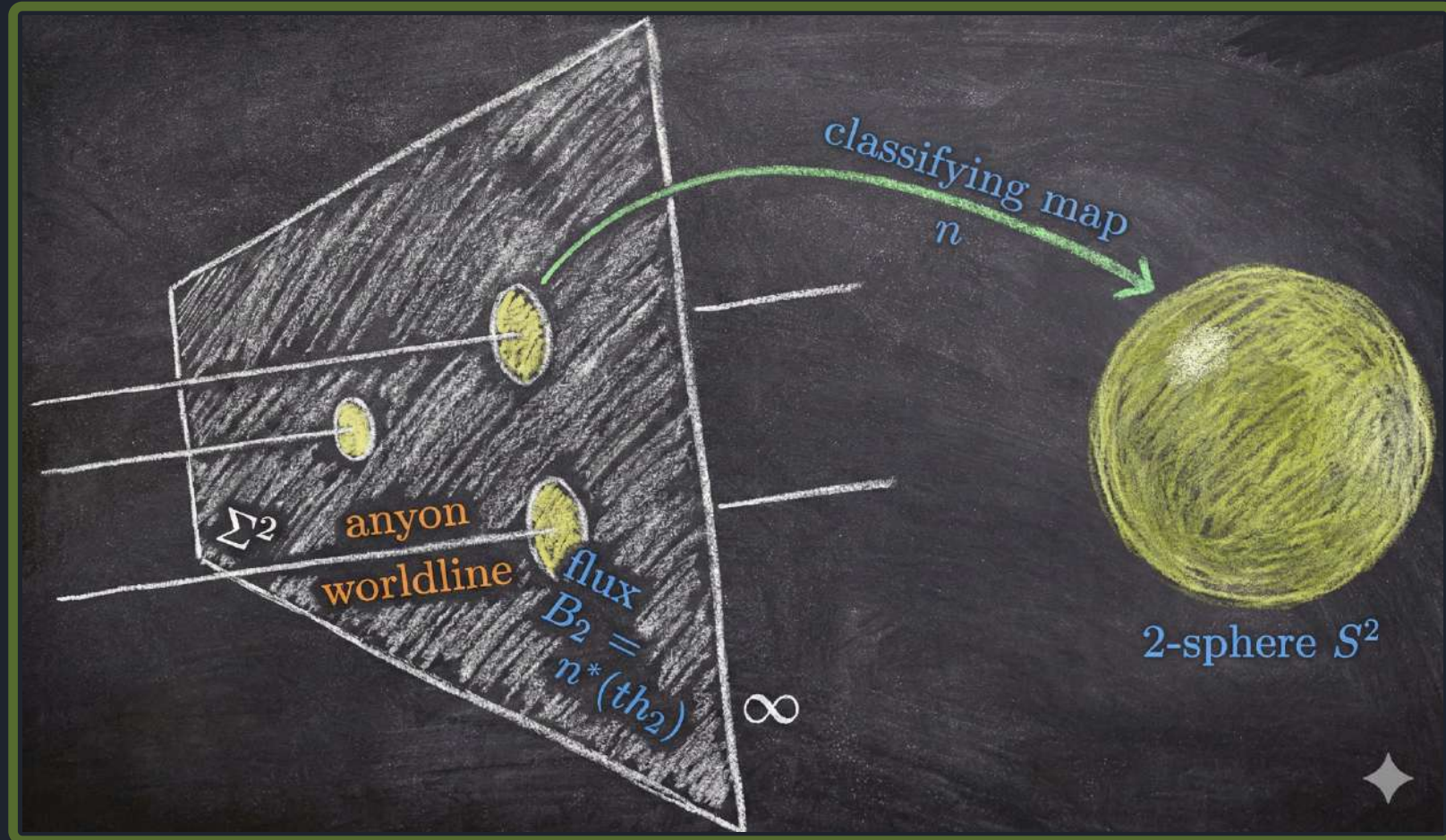

Surplus flux quanta get mapped around the 2-sphere and their worldlines exhibit anyon braiding phases!

Theorem: For surplus FQH flux this classifying space gets deformed to $\mathbb{C}P^1 \simeq S^2$

Non-Lagrangian Construction of Anyons via Flux Quantization in Cohomotopy

H. Sati and U. Schreiber

[Journal of Physics: Conference Series, Volume 3152, \(2025\)](#)

Theorem: For surplus FQH flux this classifying space gets deformed to $\mathbb{C}P^1 \simeq S^2$

Non-Lagrangian Construction of Anyons via Flux Quantization in Cohomotopy

H. Sati and U. Schreiber

Journal of Physics: Conference Series, Volume 3152, (2025)

arXiv > cond-mat > arXiv:2601.03150

Se

Condensed Matter > Strongly Correlated Electrons

[Submitted on 6 Jan 2026]

Higher-Dimensional Anyons via Higher Cohomotopy

Sadok Kallel, Hisham Sati, Urs Schreiber

Theorem: For surplus FQH flux this classifying space gets deformed to $\mathbb{C}P^1 \simeq S^2$

Non-Lagrangian Construction of Anyons via Flux Quantization in Cohomotopy

H. Sati and U. Schreiber

[Journal of Physics: Conference Series, Volume 3152, \(2025\)](#)

arXiv > cond-mat > arXiv:2601.03150

Se

Condensed Matter > Strongly Correlated Electrons

[Submitted on 6 Jan 2026]

Higher-Dimensional Anyons via Higher Cohomotopy

Sadok Kallel, Hisham Sati, Urs Schreiber

Theorem: For surplus FQH flux this classifying space gets deformed to $\mathbb{C}P^1 \simeq S^2$

Here the anyonic quantum states form “local systems” of Hilbert spaces over the covariantized mapping space

Theorem: For surplus FQH flux this classifying space gets deformed to $\mathbb{C}P^1 \simeq S^2$

Here the anyonic quantum states form “local systems” of Hilbert spaces over the covariantized mapping space meaning that they evolve along paths of configurations

Theorem: For surplus FQH flux this classifying space gets deformed to $\mathbb{C}P^1 \simeq S^2$

Here the anyonic quantum states form “local systems” of Hilbert spaces over the covariantized mapping space meaning that they evolve along paths of configurations

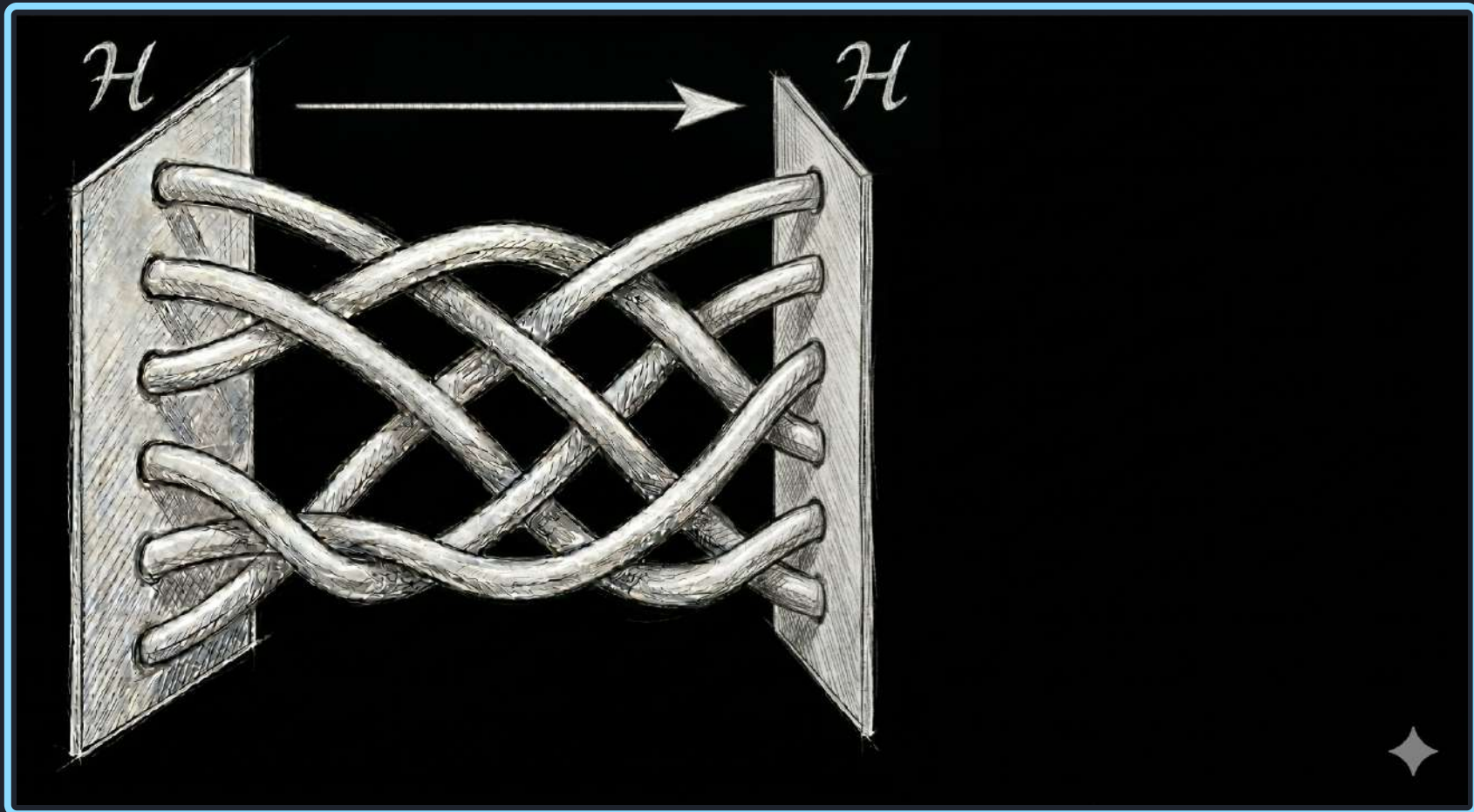

Theorem: For surplus FQH flux this classifying space gets deformed to $\mathbb{C}P^1 \simeq S^2$

Here the anyonic quantum states form “local systems” of Hilbert spaces over the covariantized mapping space meaning that they evolve along paths of configurations

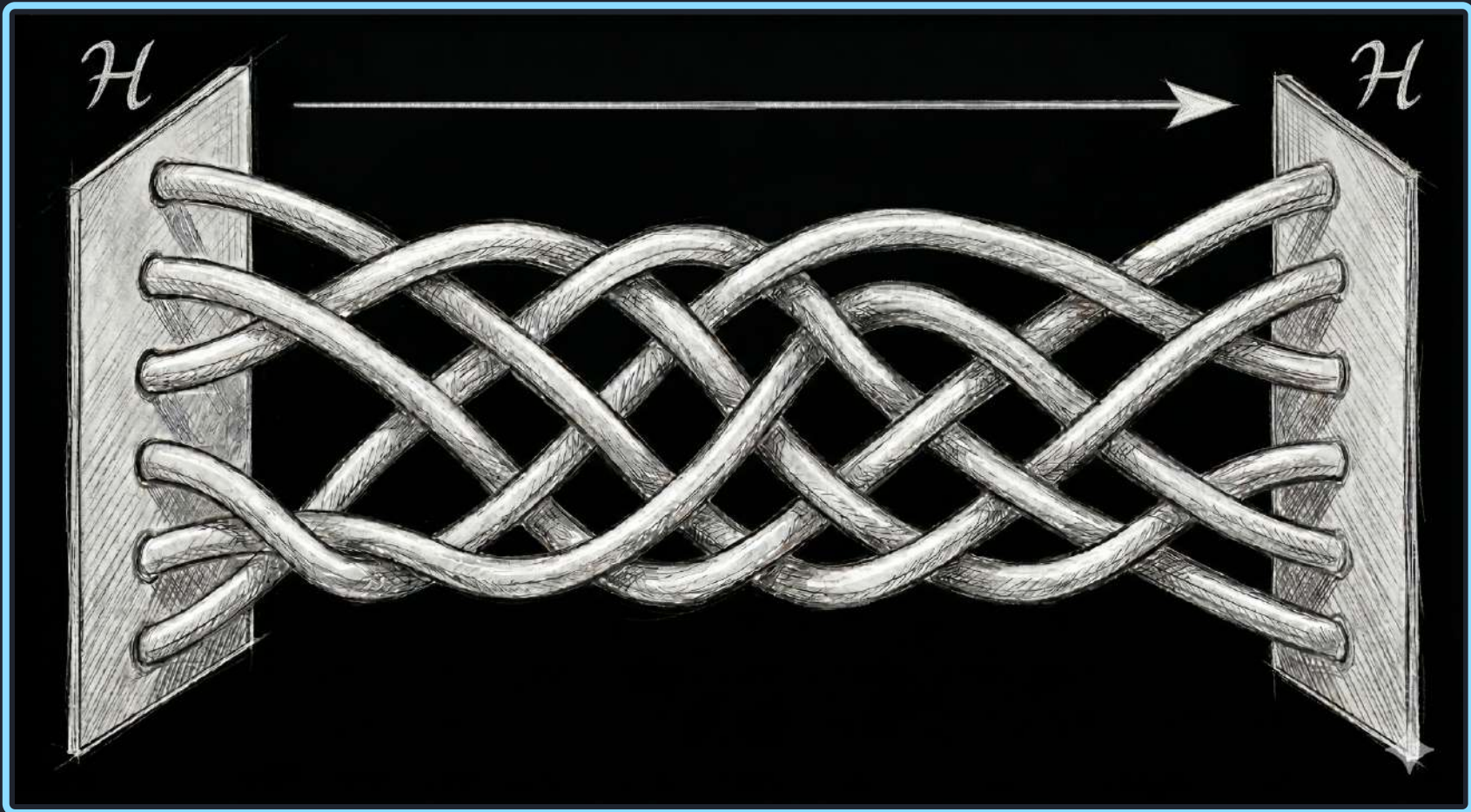

Theorem: For surplus FQH flux this classifying space gets deformed to $\mathbb{C}P^1 \simeq S^2$

Here the anyonic quantum states form “local systems” of Hilbert spaces over the covariantized mapping space meaning that they evolve along paths of configurations

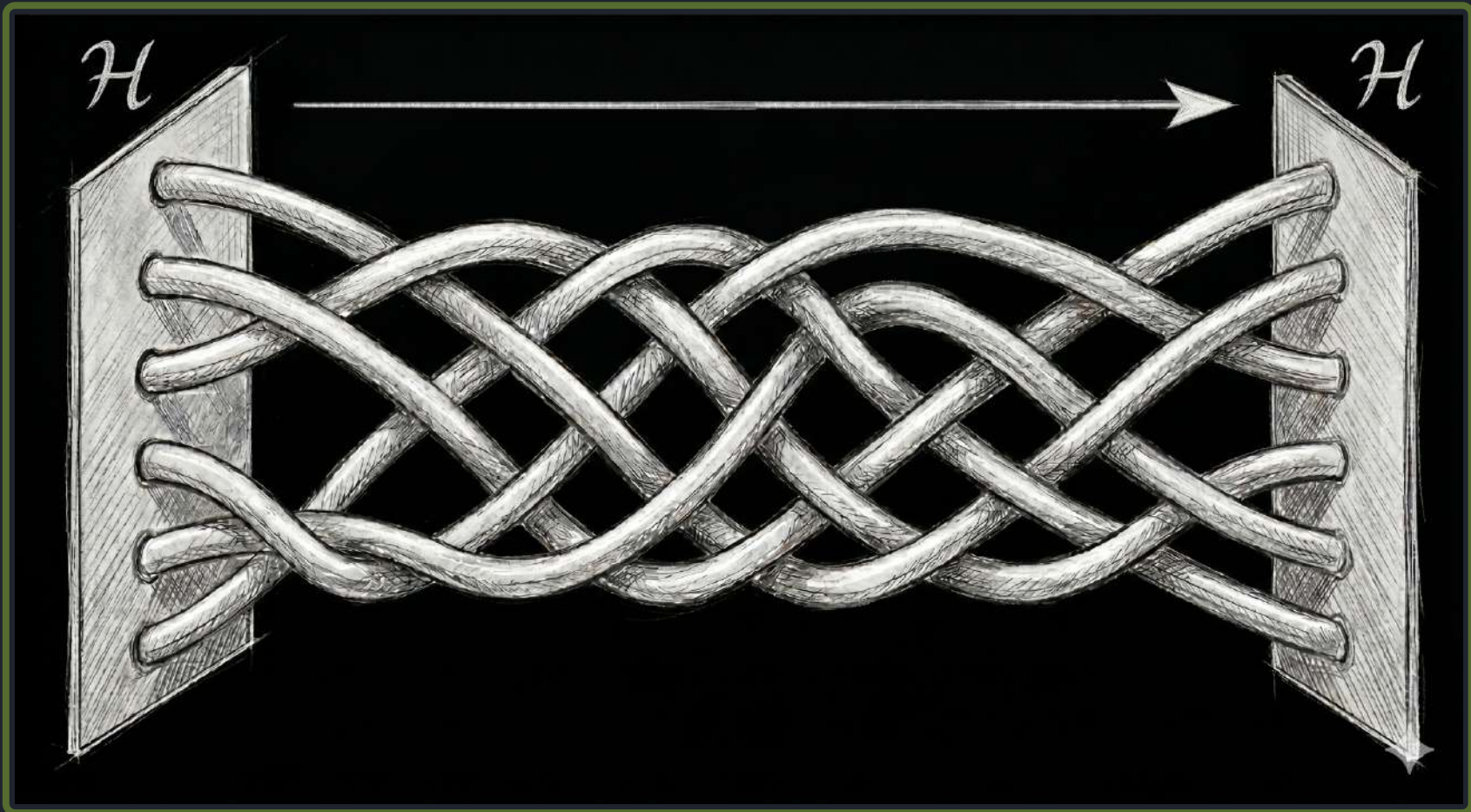

Theorem: For surplus FQH flux this classifying space gets deformed to $\mathbb{C}P^1 \simeq S^2$

Here the anyonic quantum states form “local systems” of Hilbert spaces over the covariantized mapping space

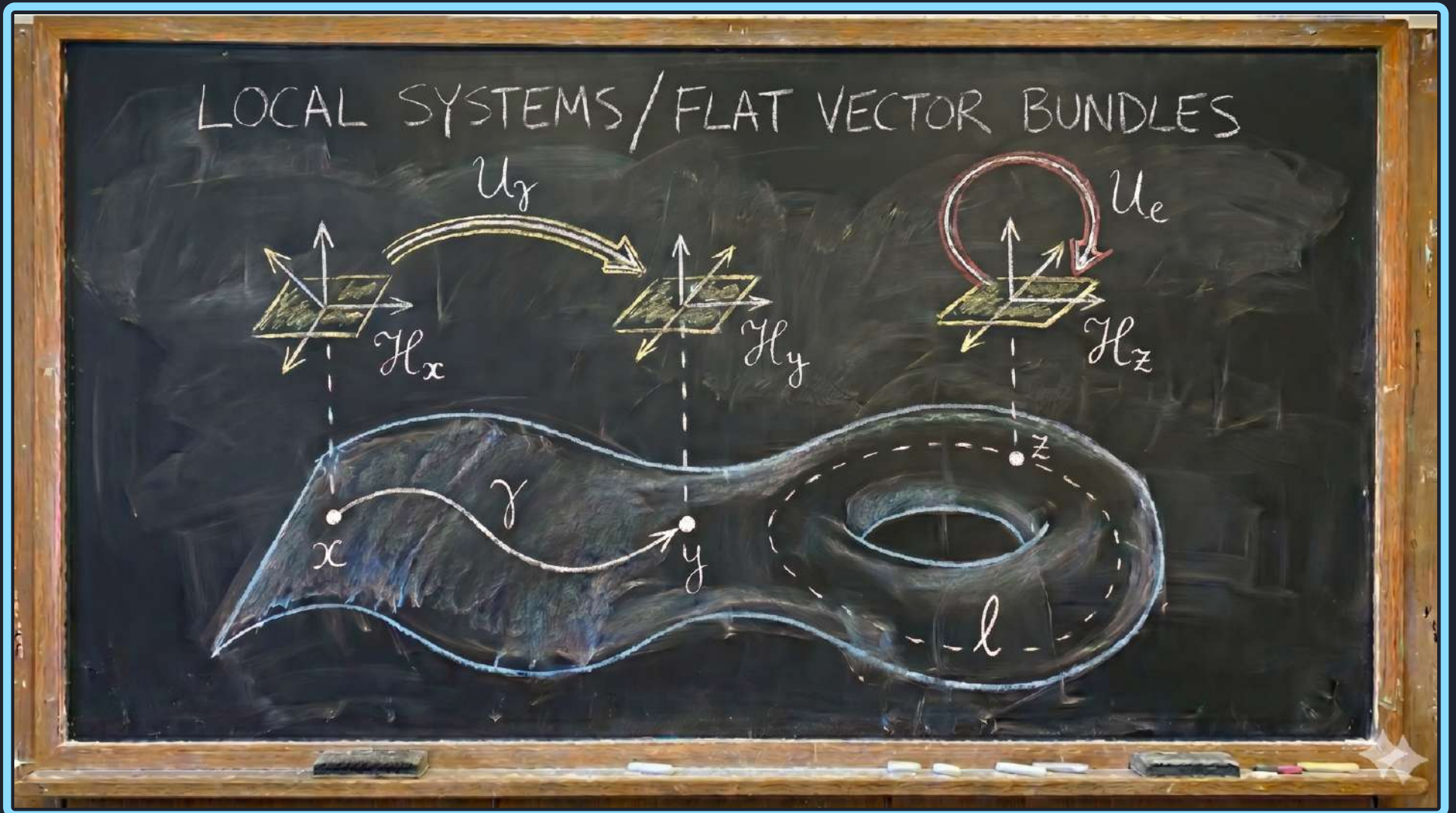

Theorem: For surplus FQH flux this classifying space gets deformed to $\mathbb{C}P^1 \simeq S^2$

Here the anyonic quantum states form “local systems” of Hilbert spaces over the covariantized mapping space

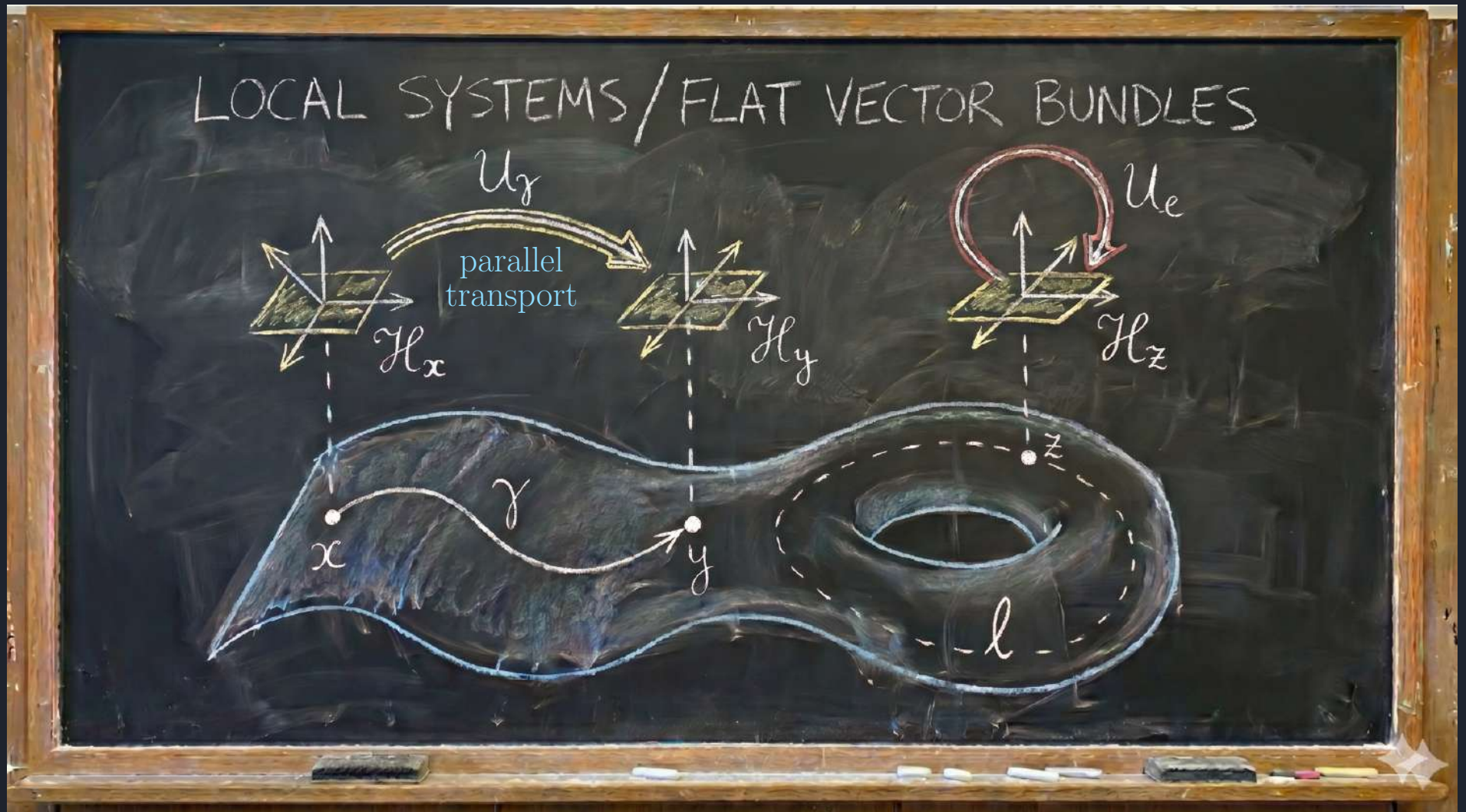

Theorem: For surplus FQH flux this classifying space gets deformed to $\mathbb{C}P^1 \simeq S^2$

Here the anyonic quantum states form “local systems” of Hilbert spaces over the covariantized mapping space

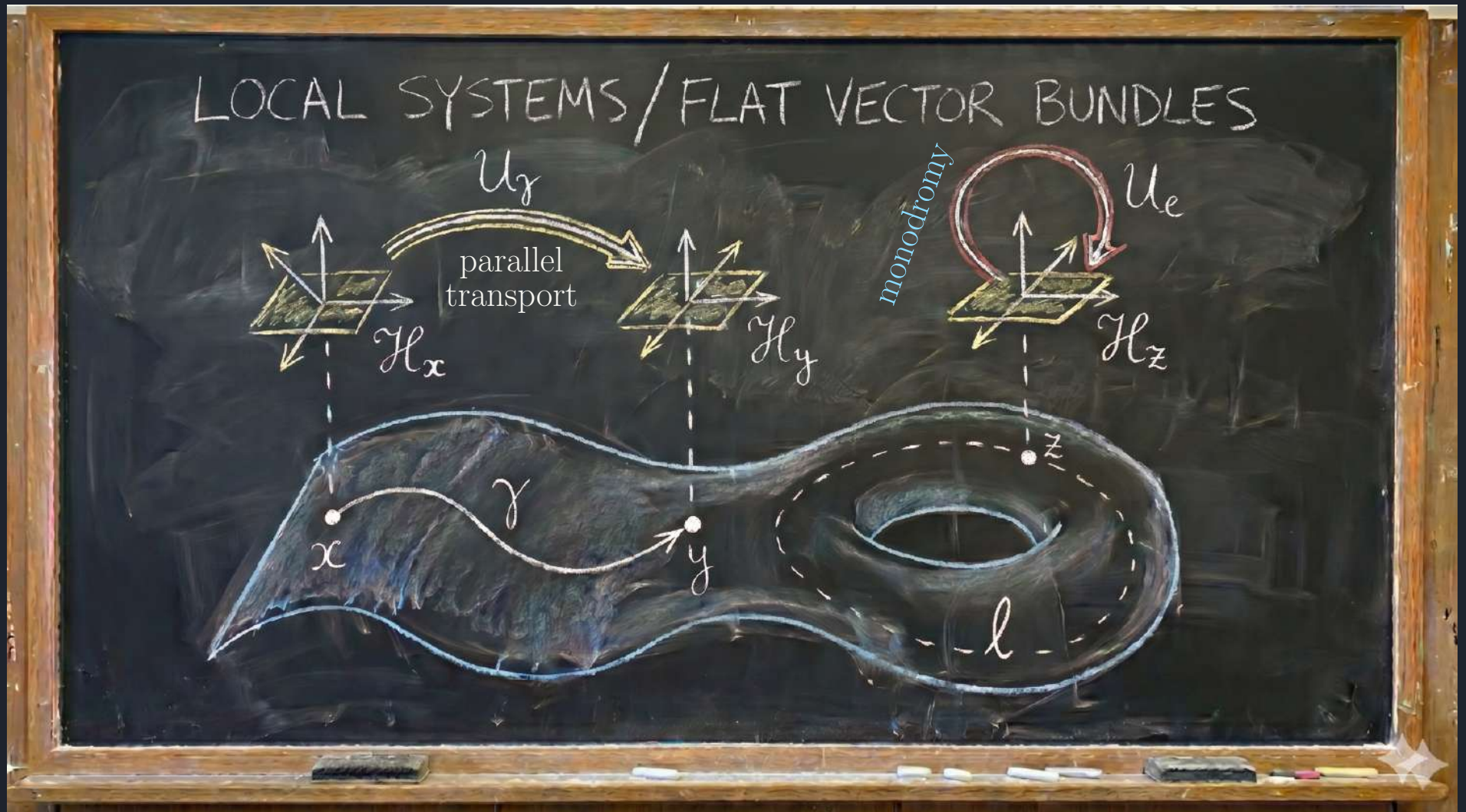

Theorem: For surplus FQH flux this classifying space gets deformed to $\mathbb{C}P^1 \simeq S^2$

Here the anyonic quantum states form “local systems” of Hilbert spaces over the covariantized mapping space

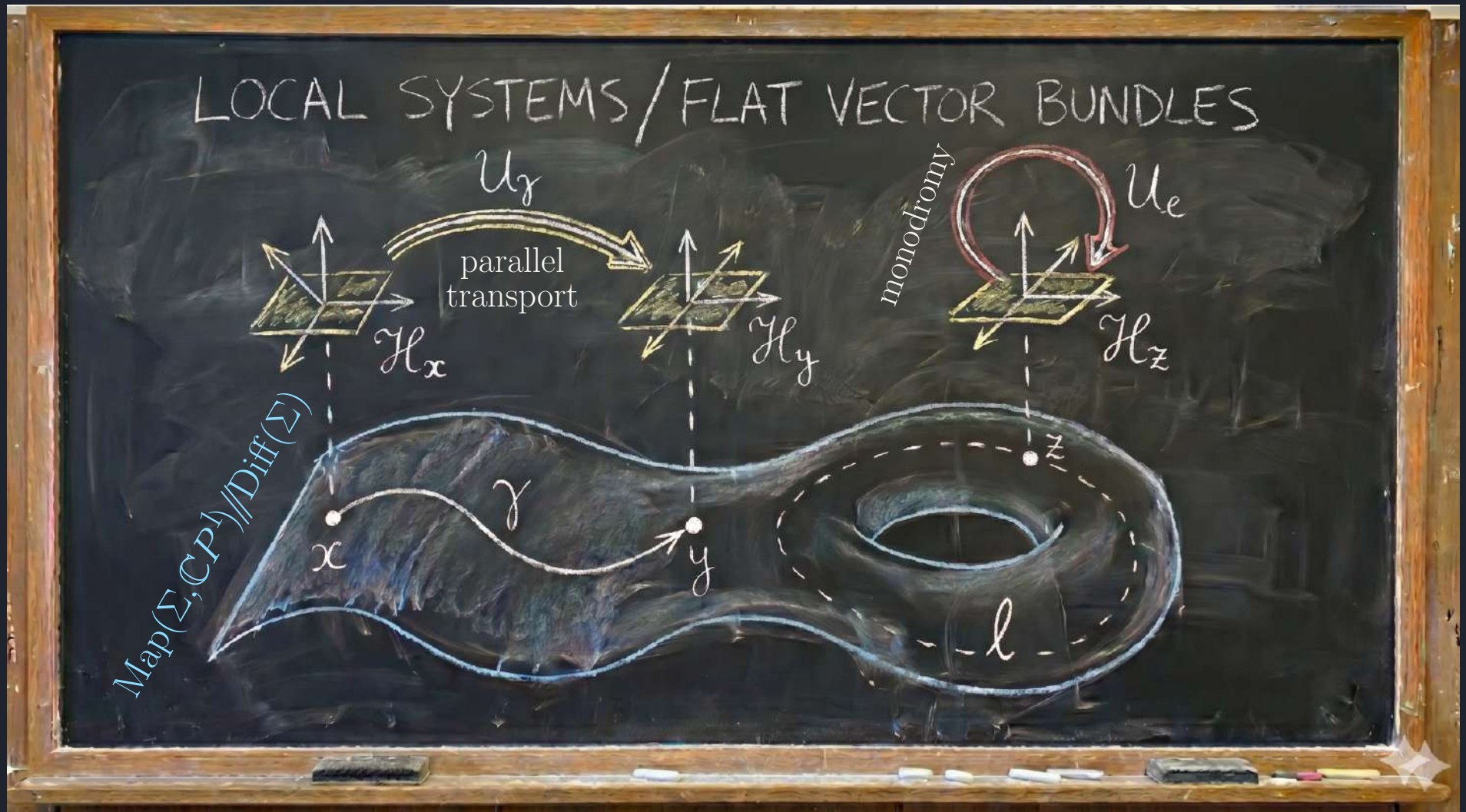

Theorem: For surplus FQH flux this classifying space gets deformed to $\mathbb{C}P^1 \simeq S^2$

Here the anyonic quantum states form “local systems” of Hilbert spaces over the covariantized mapping space

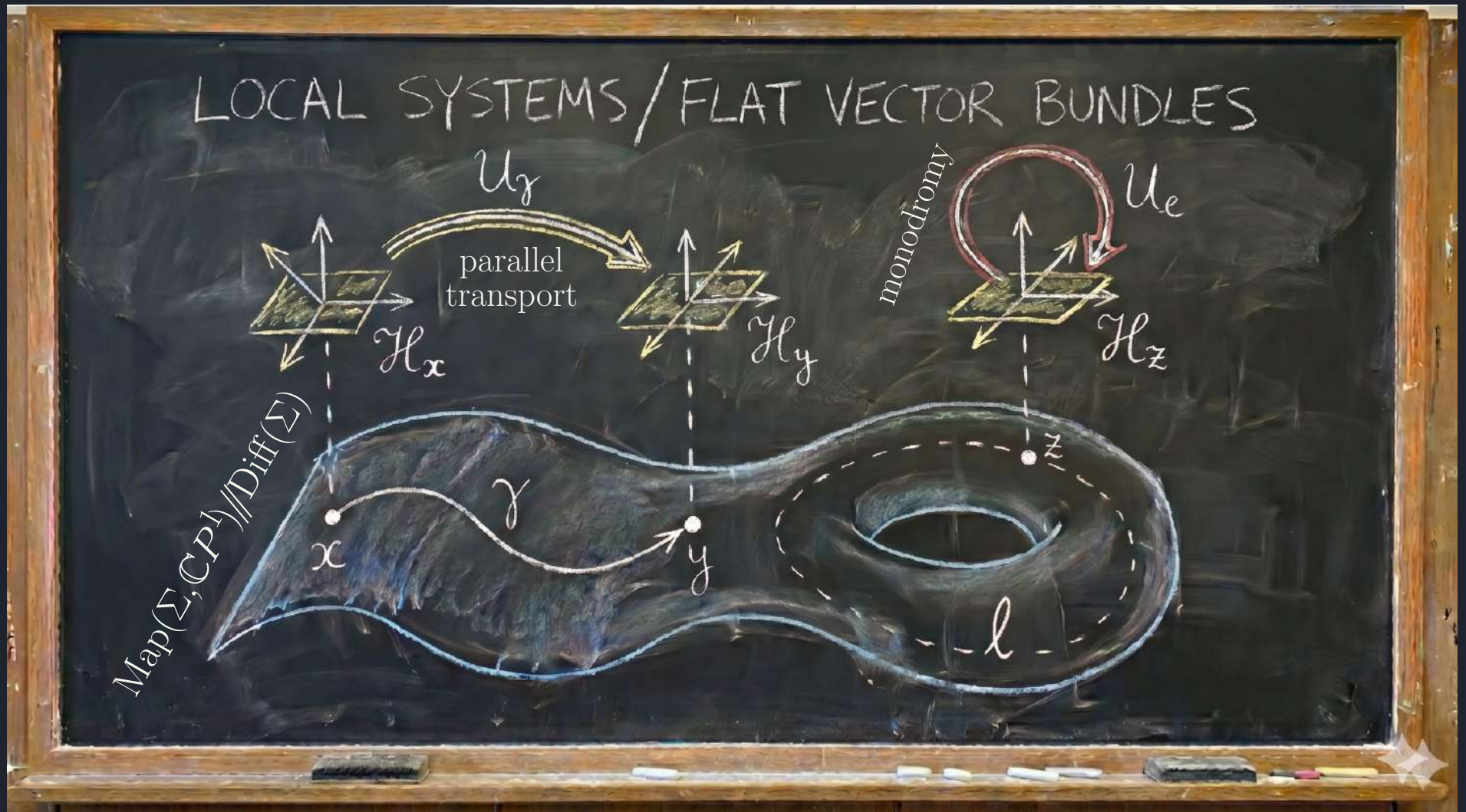

Theorem: For surplus FQH flux this classifying space gets deformed to $\mathbb{C}P^1 \simeq S^2$

Here the anyonic quantum states form “local systems” of Hilbert spaces over the covariantized mapping space

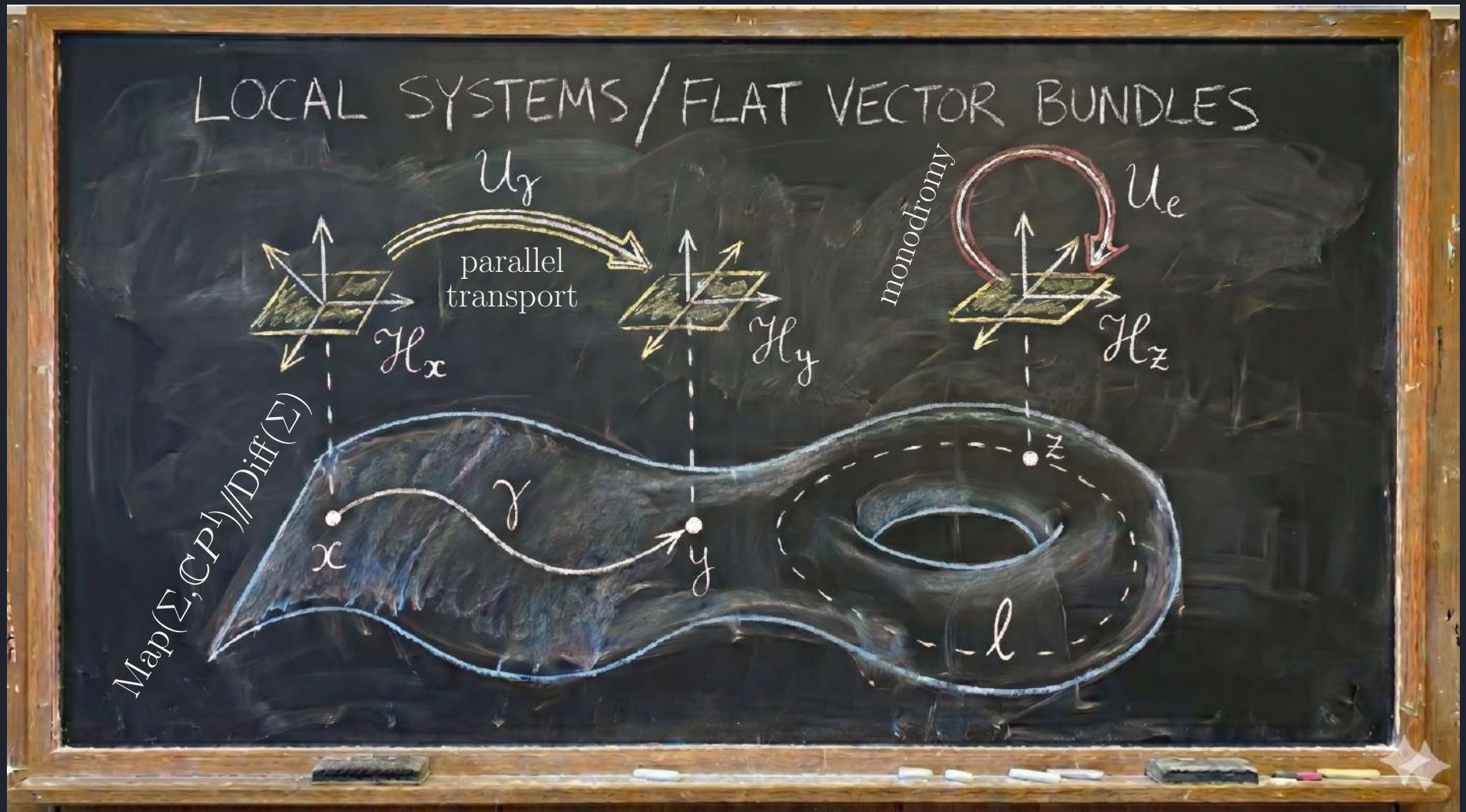

Theorem: For surplus FQH flux this classifying space gets deformed to $\mathbb{C}P^1 \simeq S^2$

Besides rigorously re-deriving the solitonic FQH anyons, this predicts nonabelian anyons attached to superconducting islands in FQH liquids

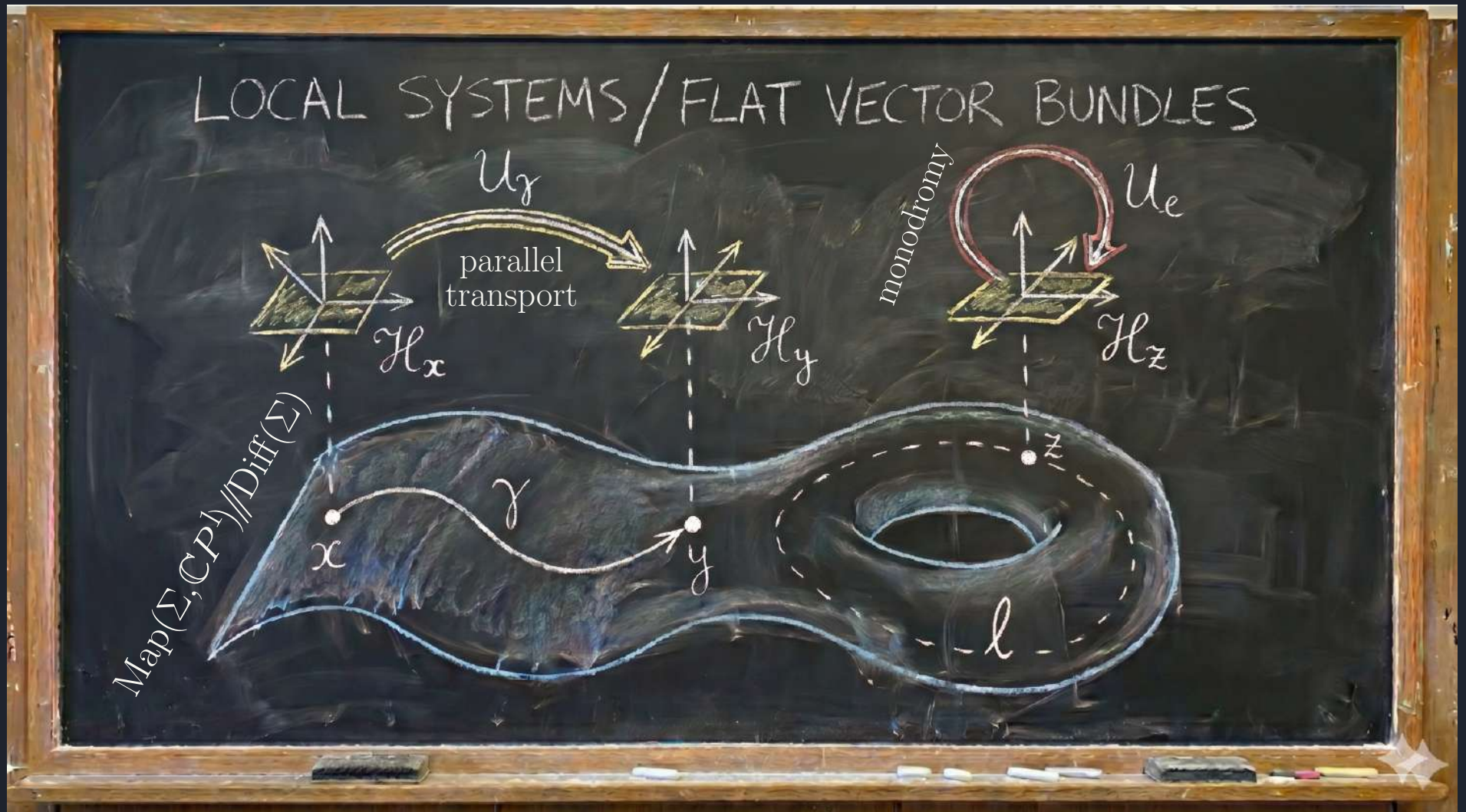

Theorem: For surplus FQH flux this classifying space gets deformed to $\mathbb{C}P^1 \simeq S^2$

Besides rigorously re-deriving the solitonic FQH anyons, this predicts nonabelian anyons attached to superconducting islands in FQH liquids



The image shows a screenshot of an arXiv preprint page. The top navigation bar is blue and contains the arXiv logo, the breadcrumb path 'cond-mat > arXiv:2602.18748', and a search box. Below the navigation bar is a dark blue header with the text 'Condensed Matter > Mesoscale and Microscale Physics'. The main content area has a white background and contains the submission date '[Submitted on 21 Feb 2026]', the title 'Nonabelian Anyons attached to Superconducting Islands in FQH Liquids' in large bold black font, and the authors 'Hisham Sati, Urs Schreiber' in a smaller black font. A small blue star icon is visible in the bottom right corner of the white content area.

arXiv > cond-mat > arXiv:2602.18748

Condensed Matter > Mesoscale and Microscale Physics

[Submitted on 21 Feb 2026]

Nonabelian Anyons attached to Superconducting Islands in FQH Liquids

Hisham Sati, Urs Schreiber

Theorem: For surplus FQH flux this classifying space gets deformed to $\mathbb{C}P^1 \simeq S^2$

Besides rigorously re-deriving the solitonic FQH anyons, this predicts nonabelian anyons attached to superconducting islands in FQH liquids

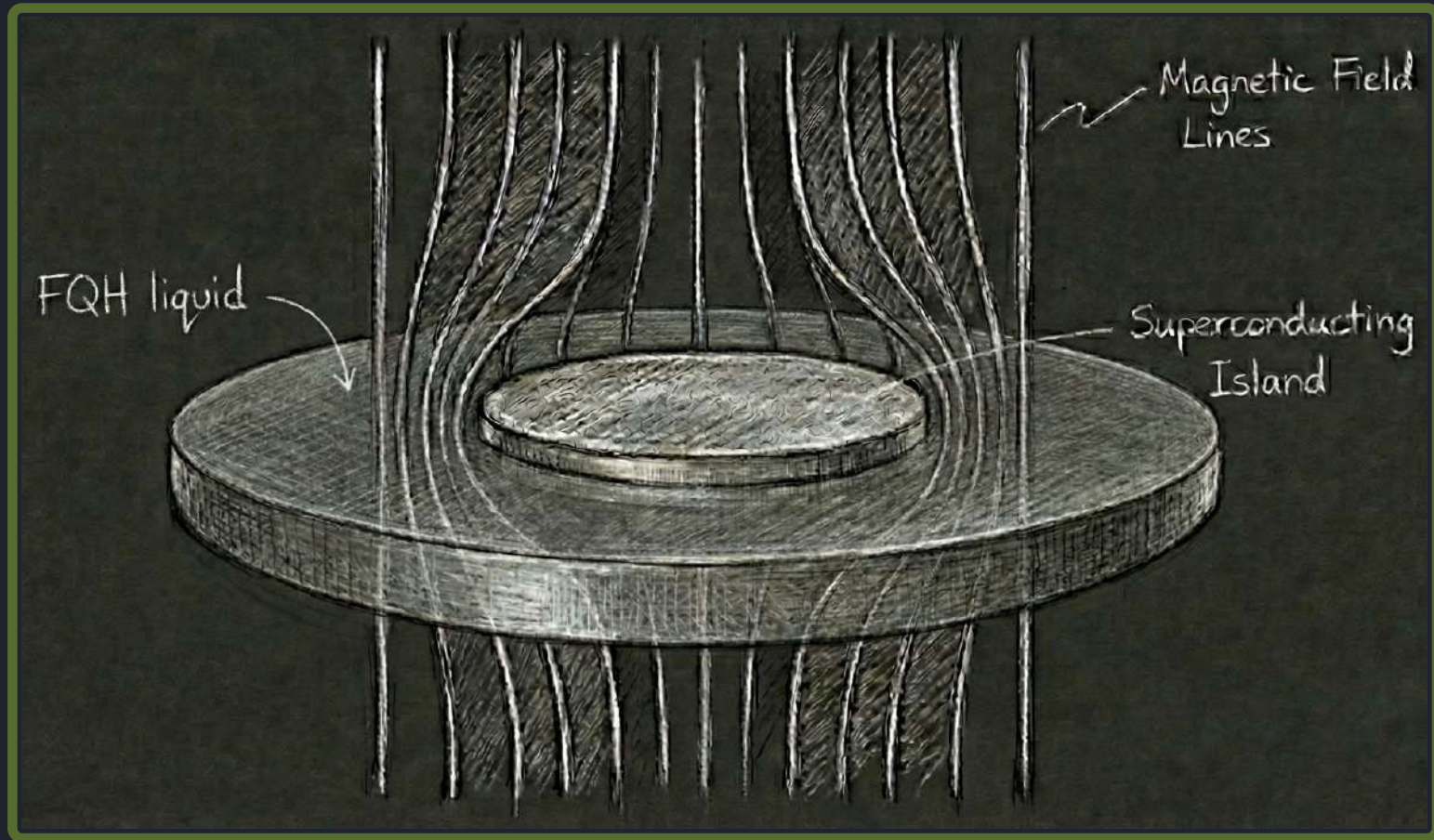

Theorem: For surplus FQH flux this classifying space gets deformed to $\mathbb{C}P^1 \simeq S^2$

Besides rigorously re-deriving the solitonic FQH anyons, this predicts nonabelian anyons attached to superconducting islands in FQH liquids



The image shows a screenshot of an arXiv preprint page. The top navigation bar is blue and contains the arXiv logo, the breadcrumb path 'cond-mat > arXiv:2602.18748', and a search box. Below the navigation bar is a dark blue header with the text 'Condensed Matter > Mesoscale and Microscale Physics'. The main content area has a white background and contains the submission date '[Submitted on 21 Feb 2026]', the title 'Nonabelian Anyons attached to Superconducting Islands in FQH Liquids', and the authors 'Hisham Sati, Urs Schreiber'. A small star icon is visible in the bottom right corner of the content area.

arXiv > cond-mat > arXiv:2602.18748

Condensed Matter > Mesoscale and Microscale Physics

[Submitted on 21 Feb 2026]

Nonabelian Anyons attached to Superconducting Islands in FQH Liquids

Hisham Sati, Urs Schreiber

Theorem: For surplus FQH flux this classifying space gets deformed to $\mathbb{C}P^1 \simeq S^2$

Besides rigorously re-deriving the solitonic FQH anyons, this predicts nonabelian anyons attached to superconducting islands in FQH liquids



The image shows a screenshot of an arXiv preprint page. The top navigation bar is blue and contains the arXiv logo, the breadcrumb path 'cond-mat > arXiv:2602.18748', and a search box. Below the navigation bar is a dark blue header with the text 'Condensed Matter > Mesoscale and Microscale Physics'. The main content area has a white background and contains the submission date '[Submitted on 21 Feb 2026]', the title 'Nonabelian Anyons attached to Superconducting Islands in FQH Liquids', and the authors 'Hisham Sati, Urs Schreiber'. A small star icon is visible in the bottom right corner of the content area.

arXiv > cond-mat > arXiv:2602.18748

Condensed Matter > Mesoscale and Microscale Physics

[Submitted on 21 Feb 2026]

Nonabelian Anyons attached to Superconducting Islands in FQH Liquids

Hisham Sati, Urs Schreiber

But with the classifying space, also Gauß' law is deformed,
since $\mathbb{C}P^1$ carries a universal *higher* flux density h_3 ,
whose divergence is the square of the 2-flux density

But with the classifying space, also Gauß' law is deformed,
since $\mathbb{C}P^1$ carries a universal *higher* flux density h_3 ,
whose divergence is the square of the 2-flux density

$$X \xrightarrow{\chi} \mathbb{C}P^1 \approx S^2$$

$$dF_2 = 0 \quad (\text{ordinary magnetic flux density})$$

$$dH_3 = \frac{1}{2} F_2 \wedge F_2 \quad (\text{higher flux density: 'Chern-Simons form', 'real Hopf generator'})$$

But with the classifying space, also Gauß' law is deformed,
since $\mathbb{C}P^1$ carries a universal *higher* flux density h_3 ,
whose divergence is the square of the 2-flux density

$$X \xrightarrow{\chi} \mathbb{C}P^1 \approx S^2$$

$$dF_2 = 0 \quad (\text{ordinary magnetic flux density})$$

$$dH_3 = \frac{1}{2} F_2 \wedge F_2 \quad (\text{higher flux density: 'Chern-Simons form', 'real Hopf generator'})$$

That's just a mathematical fact. What is its physical meaning?

But with the classifying space, also Gauß' law is deformed,
since $\mathbb{C}P^1$ carries a universal *higher* flux density h_3 ,
whose divergence is the square of the 2-flux density

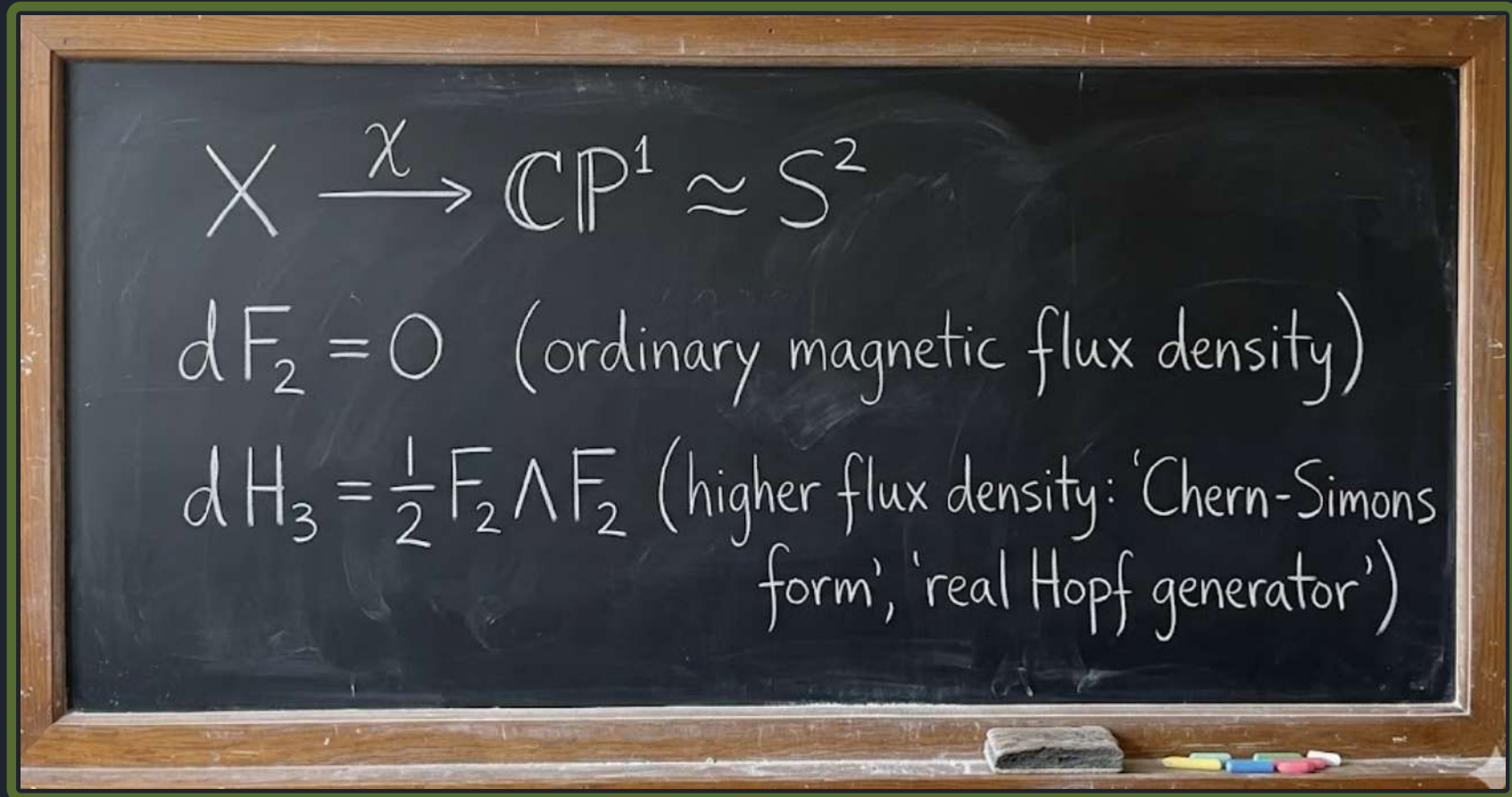

That's just a mathematical fact. What is its physical meaning?

A: These are secretly flux densities in higher dimensions!

The flux sourced by a monopole in 4D space penetrates a 3-sphere,

A: These are secretly flux densities in higher dimensions!

The flux sourced by a monopole in 4D space penetrates a 3-sphere,

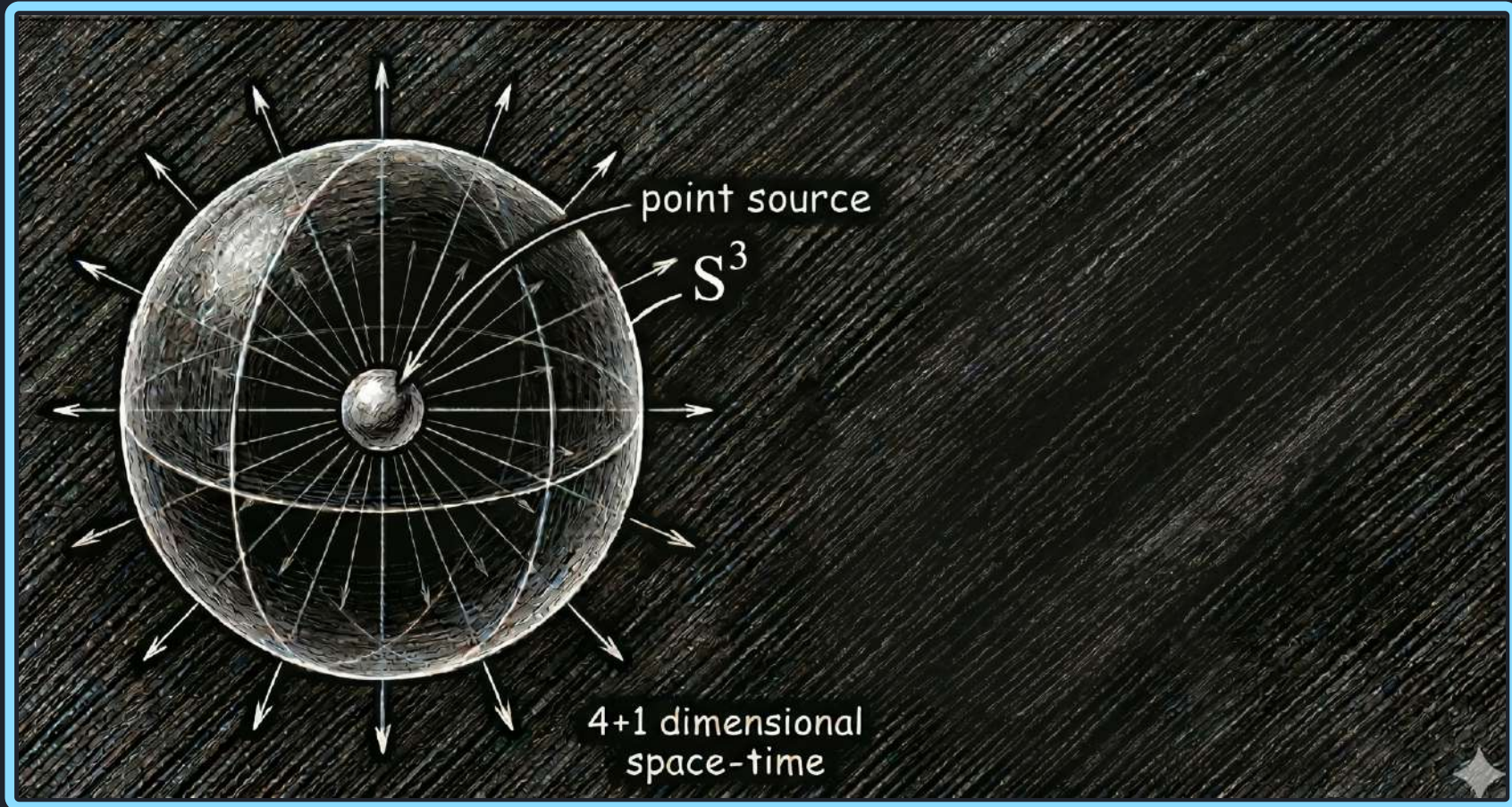

A: These are secretly flux densities in higher dimensions!

The flux sourced by a monopole in 4D space penetrates a 3-sphere,
while 2-spheres in 4D capture the flux sourced by *strings*

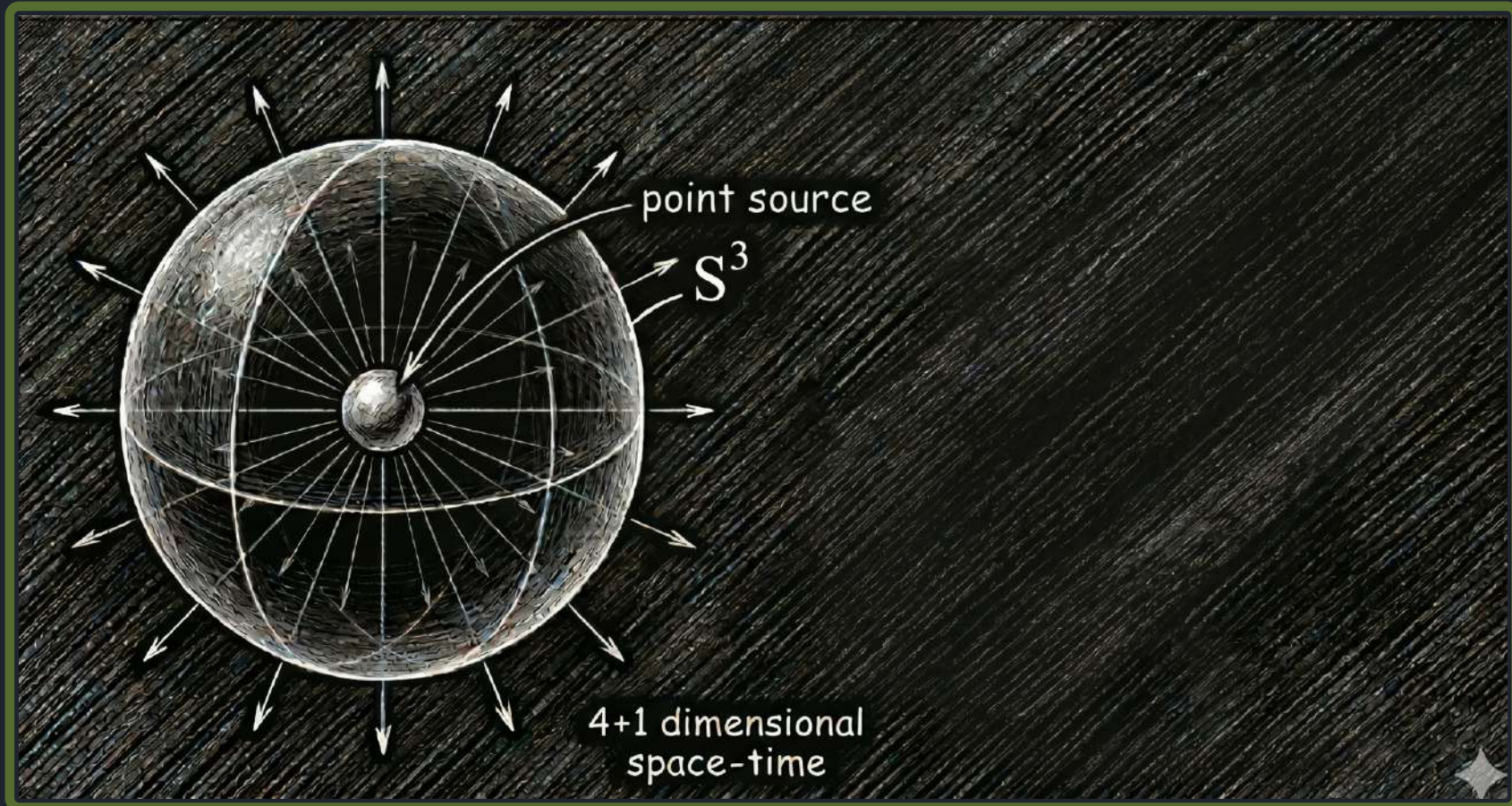

A: These are secretly flux densities in higher dimensions!

The flux sourced by a monopole in 4D space penetrates a 3-sphere, while 2-spheres in 4D capture the flux sourced by *strings*

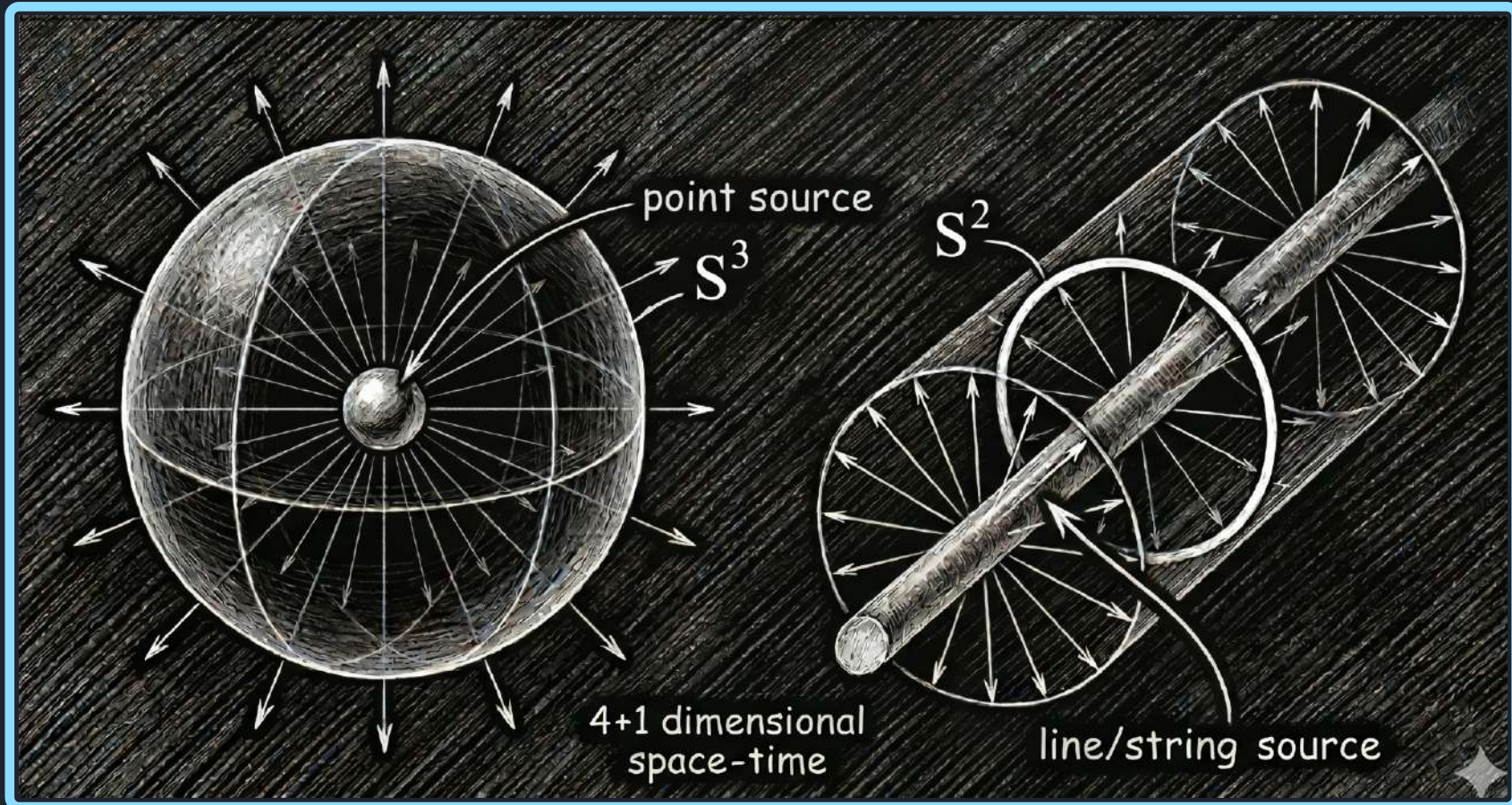

A: These are secretly flux densities in higher dimensions!

The flux sourced by a monopole in 4D space penetrates a 3-sphere, while 2-spheres in 4D capture the flux sourced by *strings*

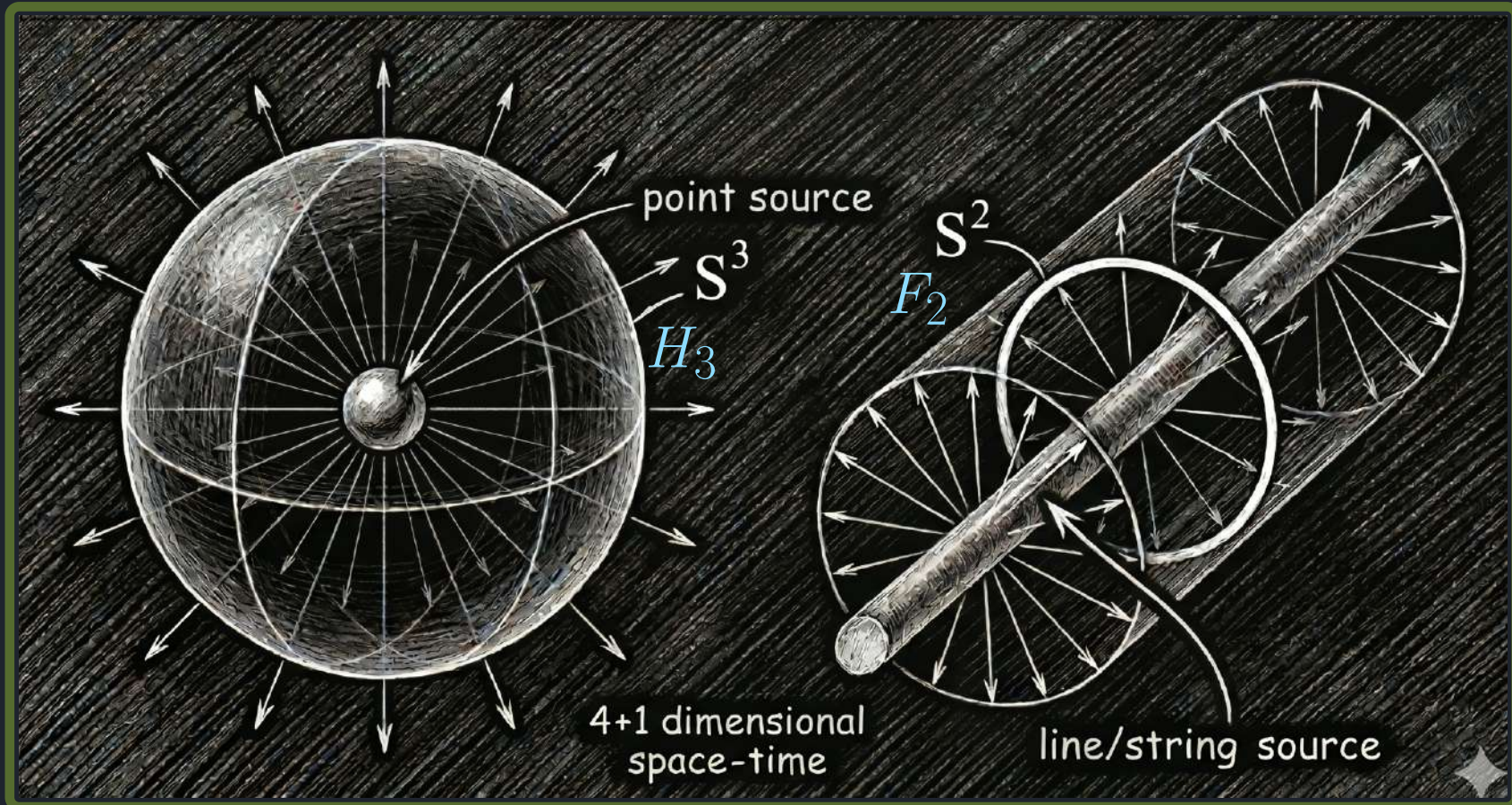

The flux sourced by a monopole in 4D space penetrates a 3-sphere, while 2-spheres in 4D capture the flux sourced by *strings*

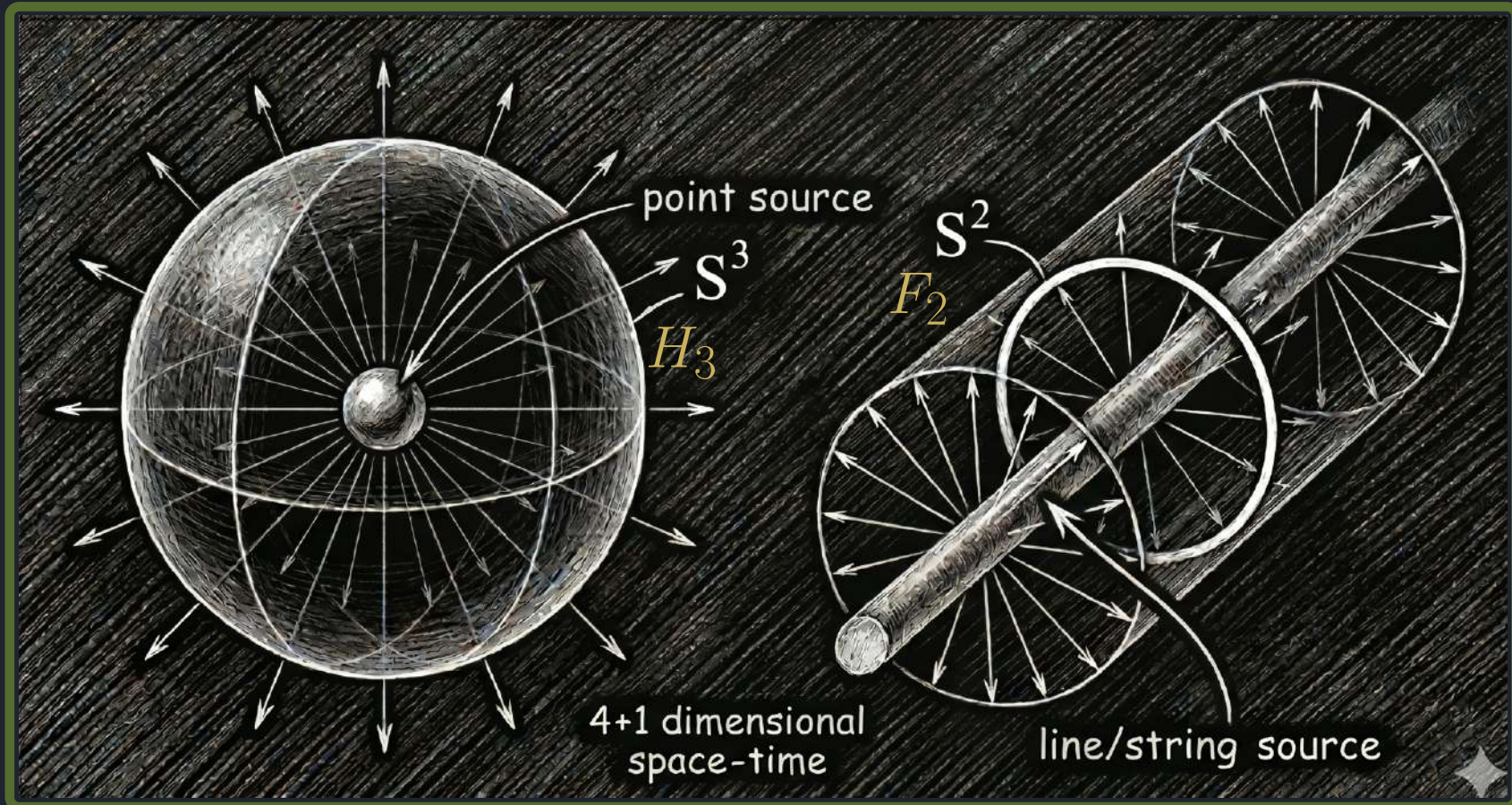

So the deformed Gauß law for FQH anyons that we found

$$X \xrightarrow{\chi} \mathbb{C}P^1 \approx S^2$$

$$dF_2 = 0 \quad (\text{ordinary magnetic flux density})$$

$$dH_3 = \frac{1}{2} F_2 \wedge F_2 \quad (\text{higher flux density: 'Chern-Simons form', 'real Hopf generator'})$$

So the deformed Gauß law for FQH anyons that we found

$$X \xrightarrow{\chi} \mathbb{C}P^1 \approx S^2$$

$$dF_2 = 0 \quad (\text{ordinary magnetic flux density})$$

$$dH_3 = \frac{1}{2} F_2 \wedge F_2 \quad (\text{higher flux density: 'Chern-Simons form', 'real Hopf generator'})$$

So the deformed Gauß law for FQH anyons that we found is of a higher dim field theory with higher dim sources (“branes”)

$$X \xrightarrow{\chi} \mathbb{C}P^1 \approx S^2$$

$$dF_2 = 0 \quad (\text{ordinary magnetic flux density})$$

$$dH_3 = \frac{1}{2} F_2 \wedge F_2 \quad (\text{higher flux density: 'Chern-Simons form', 'real Hopf generator'})$$

So the deformed Gauß law for FQH anyons that we found is of a higher dim field theory with higher dim sources (“branes”) like one known as “5D Maxwell Chern-Simons theory” (MCS)

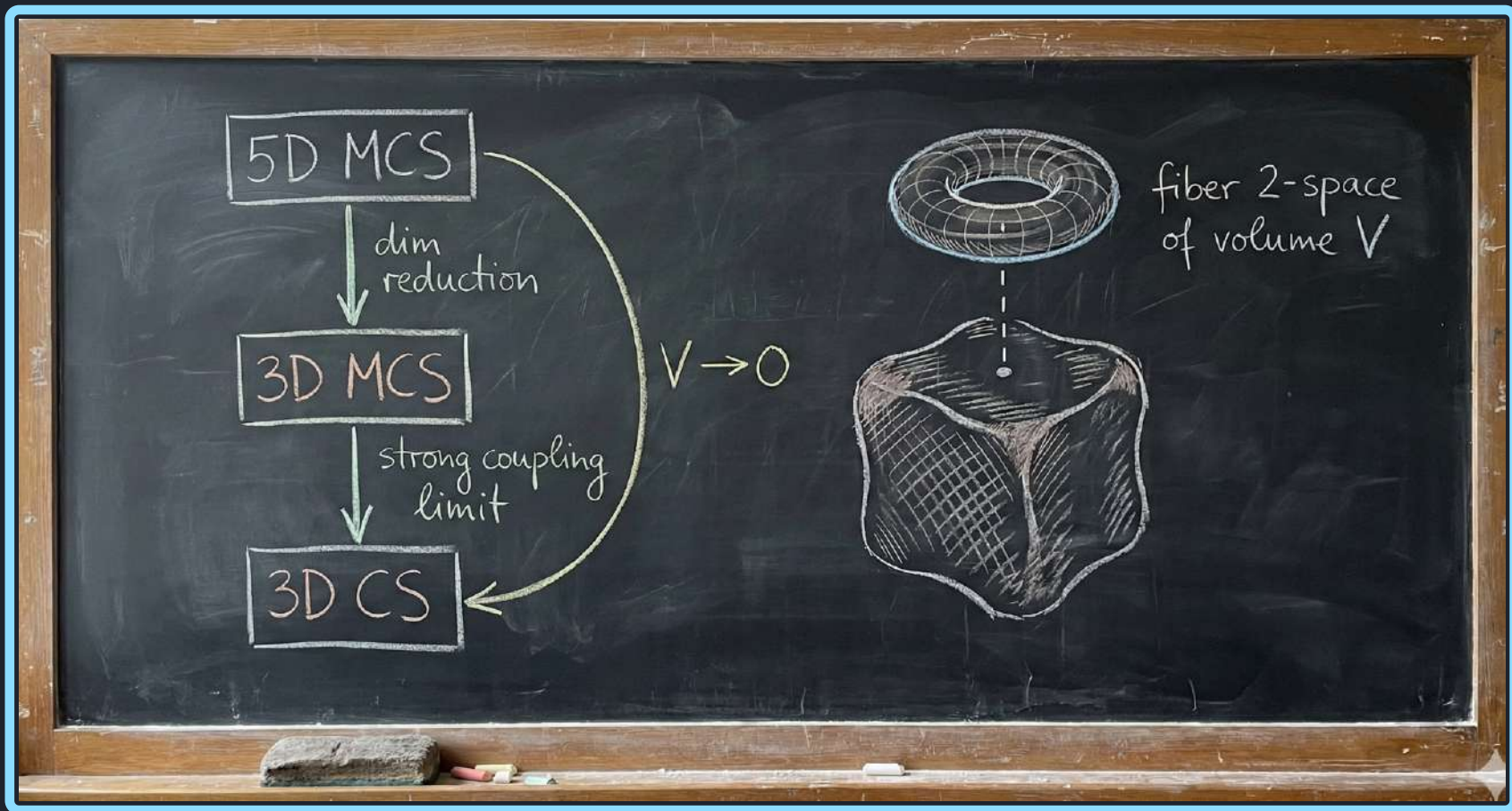

a higher dim field theory with higher dim sources (“branes”) like one known as “5D Maxwell Chern-Simons theory” (MCS)

Renormalization of Chern–Simons Wilson loops via proper flux quantization in cohomotopy

Hisham Sati and Urs Schreiber ✉

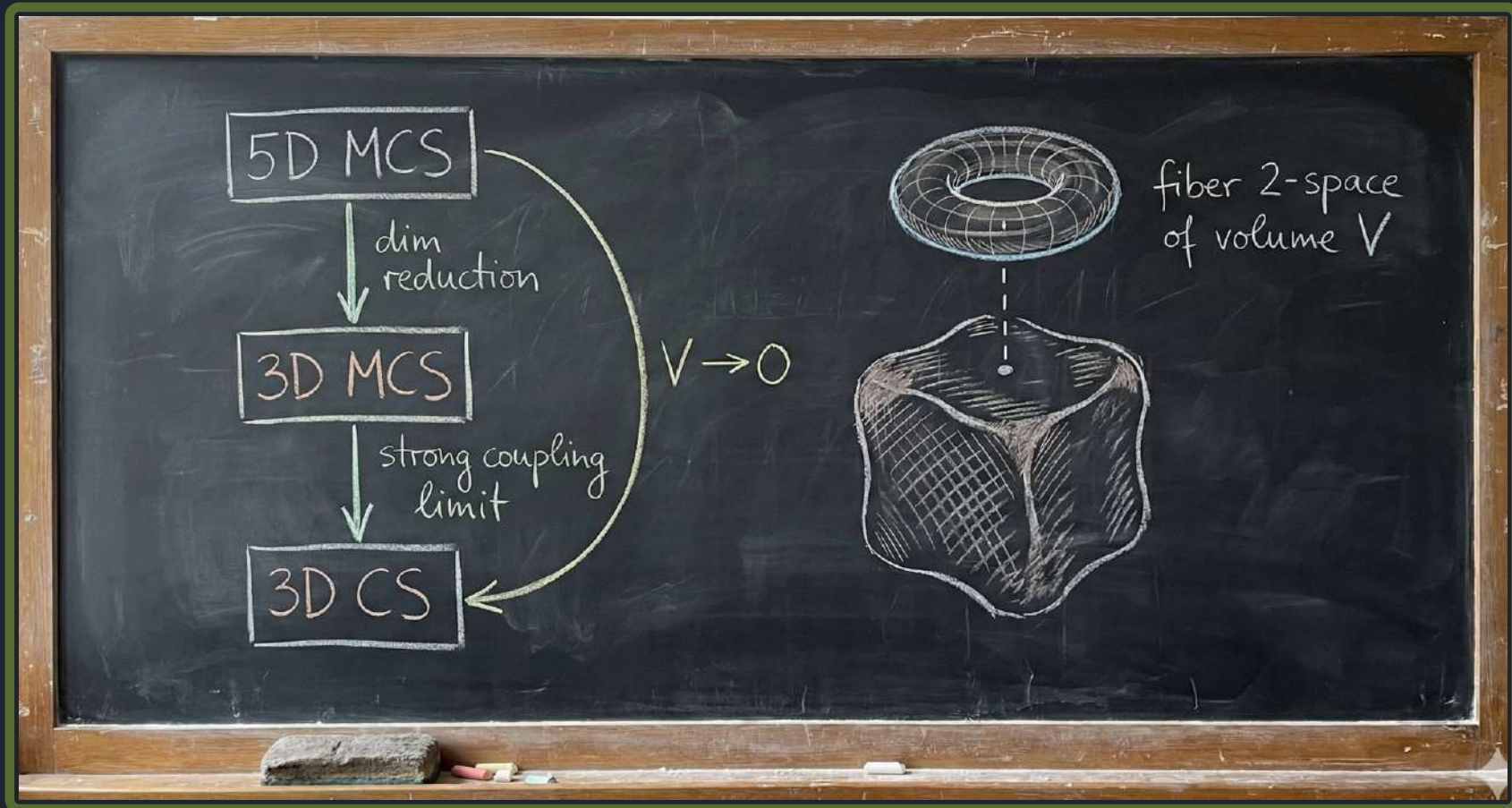

a higher dim field theory with higher dim sources (“branes”) like one known as “5D Maxwell Chern-Simons theory” (MCS)

Renormalization of Chern–Simons Wilson loops via proper flux quantization in cohomotopy

Hisham Sati and Urs Schreiber ✉

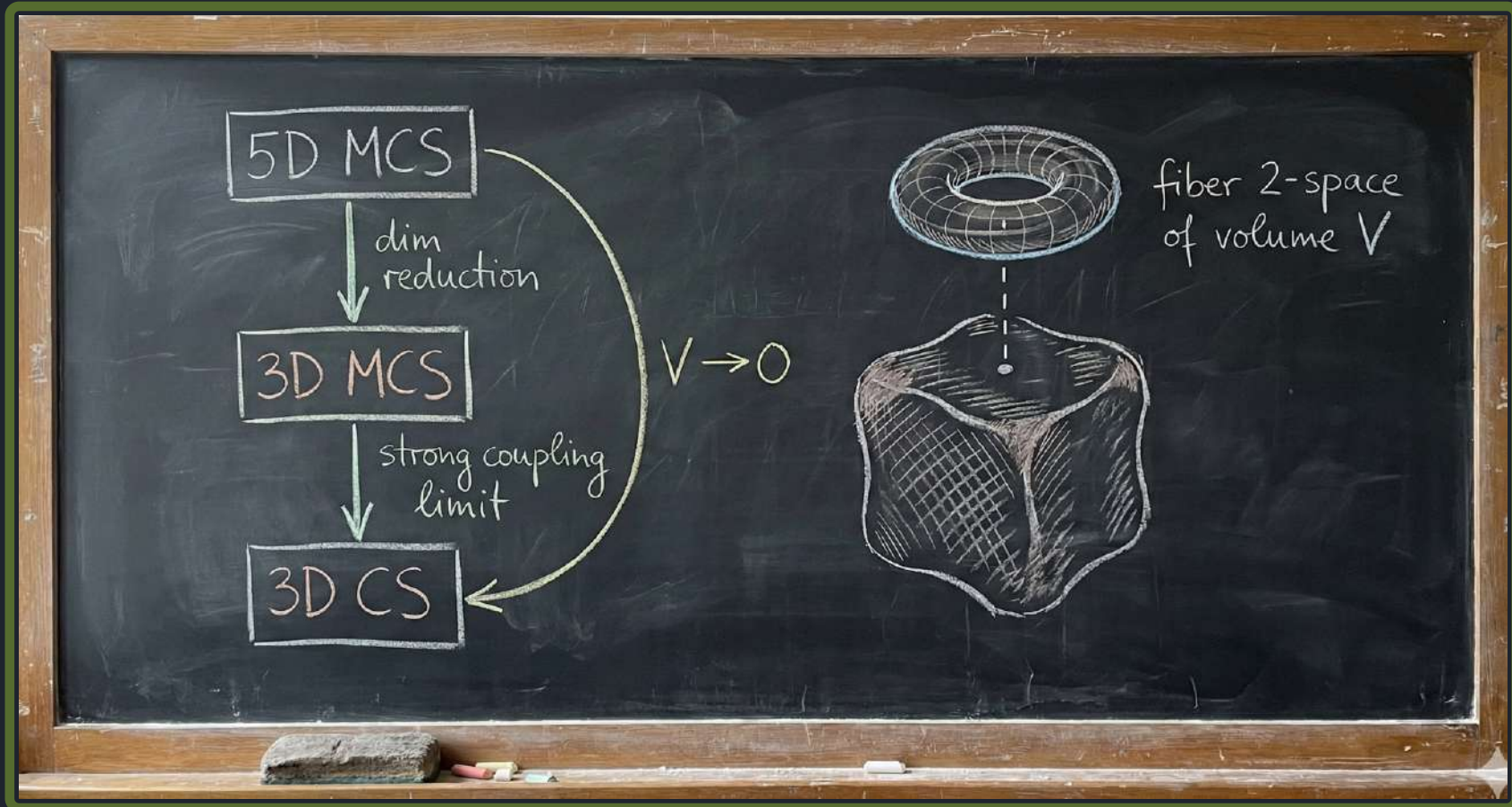

a higher dim field theory with higher dim sources (“branes”) like one known as “5D Maxwell Chern-Simons theory” (MCS)

Generally: Higher fluxes in higher dimensions
have (graded) polynomial Gauß laws

Generally: Higher fluxes in higher dimensions
have (graded) polynomial Gauß laws

Higher electromagnetic fields

higher flux densities: $\vec{F} := \{F^{(i)} \in \Omega_{dR}^{\text{deg}_i}(X)\}_{i \in I}$

higher Gauss laws: $dF^{(i)} = P^i(\vec{F})$ (graded polynomial)

duality relations: $\star F^{(i)} = \mu^i(\vec{F})$ (invertible linear)

Generally: Higher fluxes in higher dimensions
have (graded) polynomial Gauß laws

Example: 11D Supergravity ("M-Theory")

higher flux densities: G_4 and G_7

higher Gauß laws: $dG_4 = 0$, $dG_7 = \frac{1}{2}G_4 \wedge G_4$

duality relations: $G_7 = \star G_4$

Generally: Higher fluxes in higher dimensions
have (graded) polynomial Gauß laws

Higher electromagnetic fields

higher flux densities: $\vec{F} := \{F^{(i)} \in \Omega_{dR}^{\deg_i}(X)\}_{i \in I}$

higher Gauß laws: $dF^{(i)} = P^i(\vec{F})$ (graded polynomial)

duality relations: $\star F^{(i)} = \mu^i(\vec{F})$ (invertible linear)

Such Gauß laws equivalently characterize closed differential forms with coefficients in a *homotopy Lie algebra* \mathfrak{a} .

Generally: Higher fluxes in higher dimensions
have (graded) polynomial Gauß laws

Higher electromagnetic fields

higher flux densities: $\vec{F} := \{F^{(i)} \in \Omega_{dR}^{\deg_i}(X)\}_{i \in I}$

higher Gauß laws: $dF^{(i)} = P^i(\vec{F})$ (graded polynomial)

duality relations: $\star F^{(i)} = \mu^i(\vec{F})$ (invertible linear)

Such Gauß laws equivalently characterize closed differential forms with coefficients in a *homotopy Lie algebra* \mathfrak{a} .

shorthand symbol for higher Gauß laws

Generally: Higher fluxes in higher dimensions
have (graded) polynomial Gauß laws

[Home](#) > [Annales Henri Poincaré](#) > Article

Flux Quantization on Phase Space

[H. Sati](#) and [U. Schreiber](#)

Volume 26, pages 895–919, (2025)

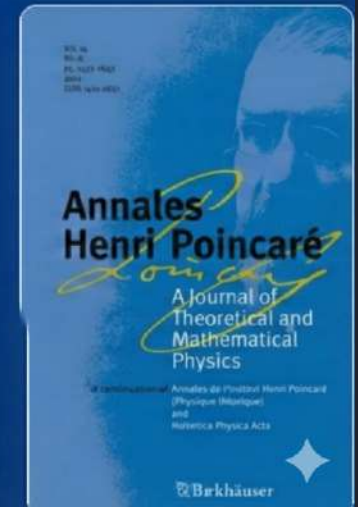

Such Gauß laws equivalently characterize closed differential forms with coefficients in a *homotopy Lie algebra* \mathfrak{a} .

shorthand symbol for higher Gauß laws

Generally: Higher fluxes in higher dimensions
have (graded) polynomial Gauß laws

[Home](#) > [Annales Henri Poincaré](#) > [Article](#)

Flux Quantization on Phase Space

[H. Sati](#) and [U. Schreiber](#)

Volume 26, pages 895–919, (2025)

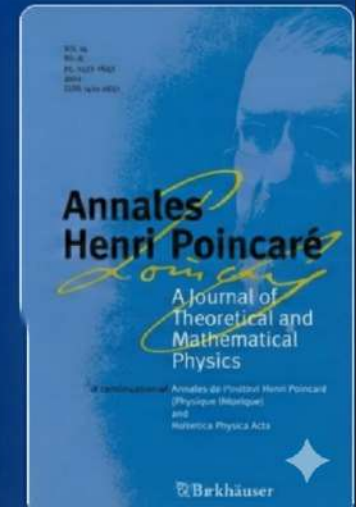

Such Gauß laws equivalently characterize closed differential forms with coefficients in a *homotopy Lie algebra* \mathfrak{a} .

shorthand symbol for higher Gauß laws

A *character map* associates such higher Gauß laws to classifying spaces:

A *character map* associates such higher Gauß laws to classifying spaces:

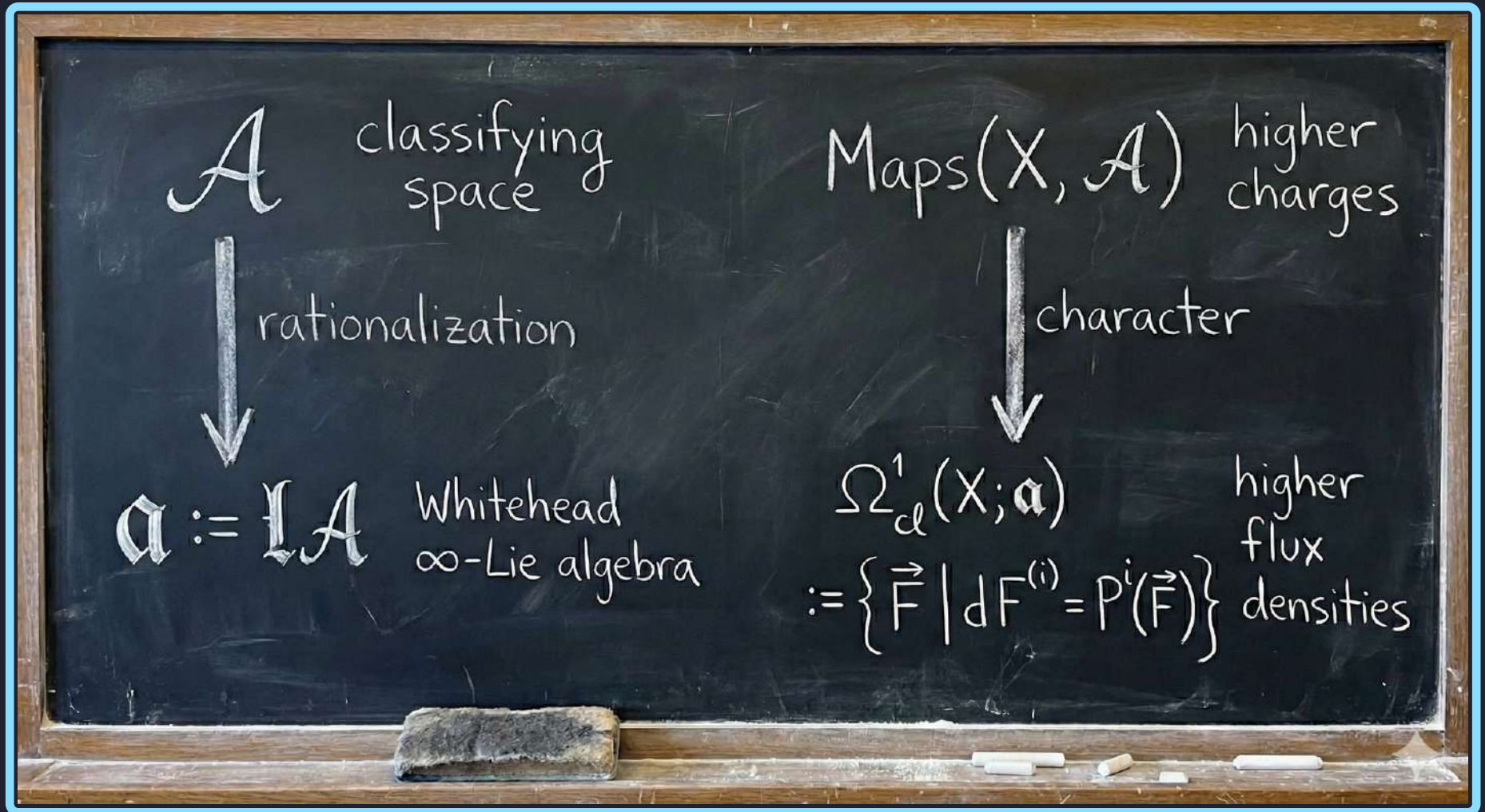

A *character map* associates such higher Gauß laws to classifying spaces:

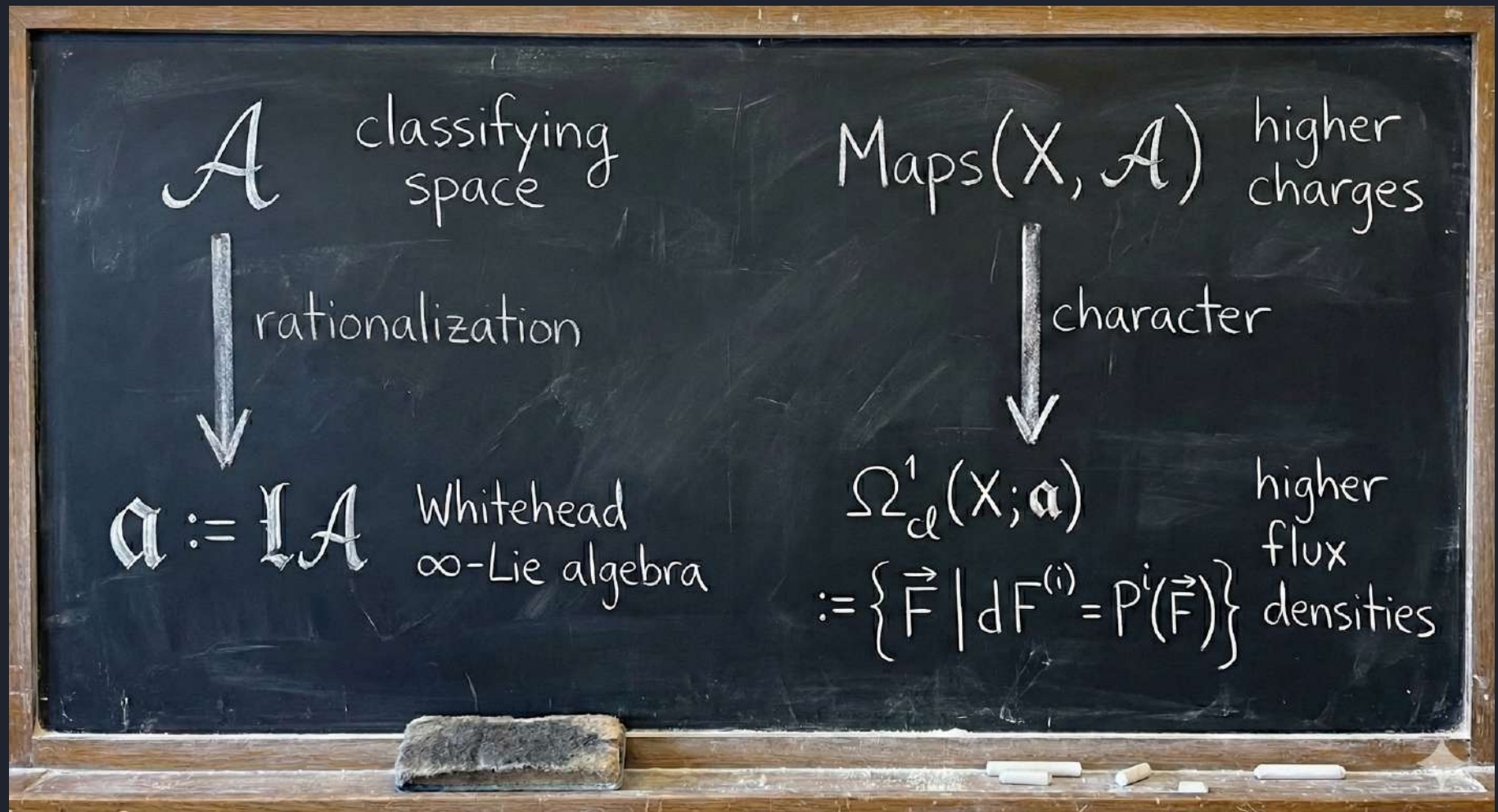

Hence global completion of a higher field theory by flux quantization is to choose \mathcal{A} such that $\mathfrak{L}\mathcal{A} \simeq \mathfrak{a}$

A *character map* associates such higher Gauß laws to classifying spaces:

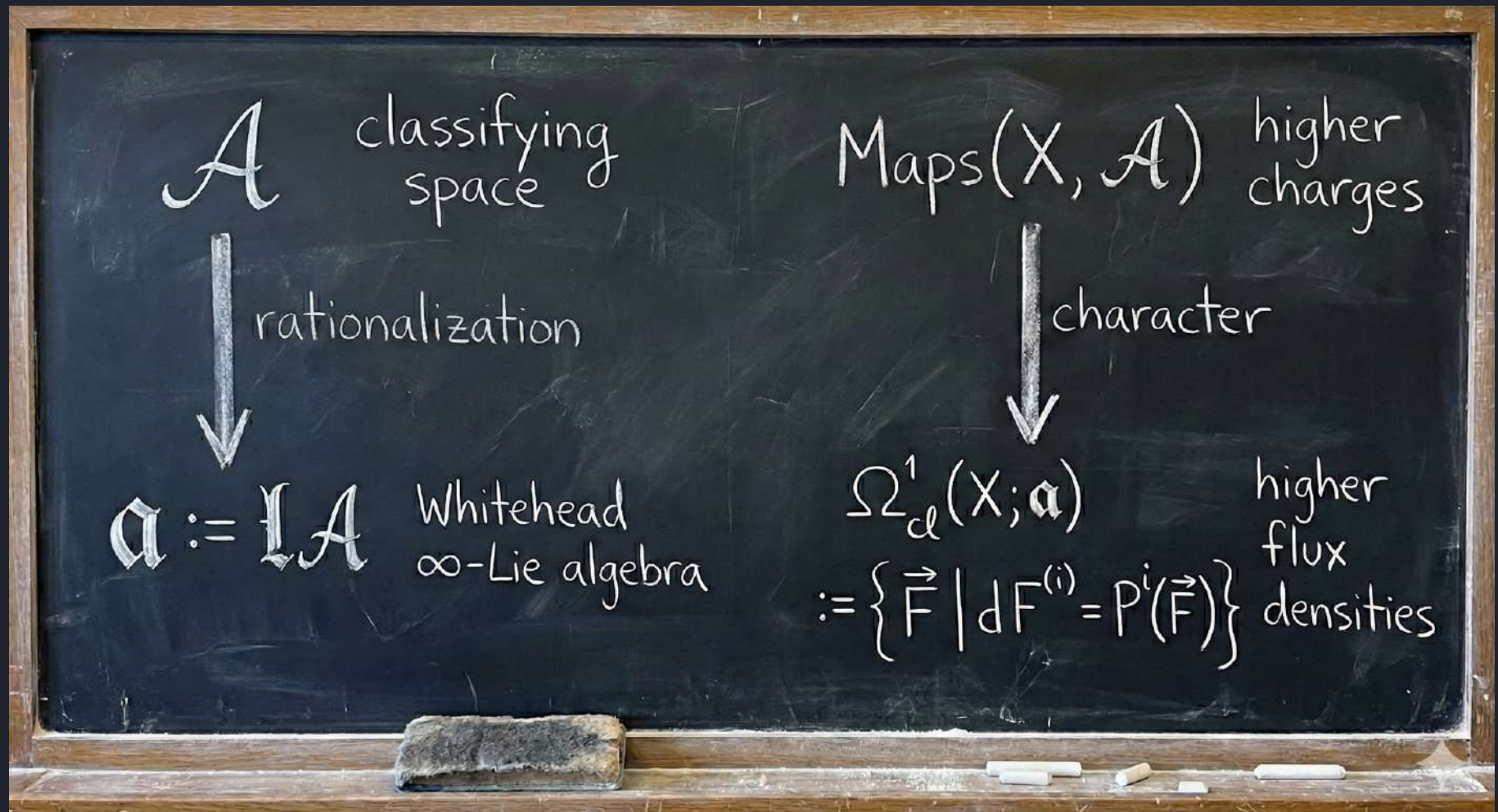

Hence global completion of a higher field theory by flux quantization is to choose \mathcal{A} such that $\mathfrak{L}\mathcal{A} \simeq \mathfrak{a}$

A *character map* associates such higher Gauß laws to classifying spaces:

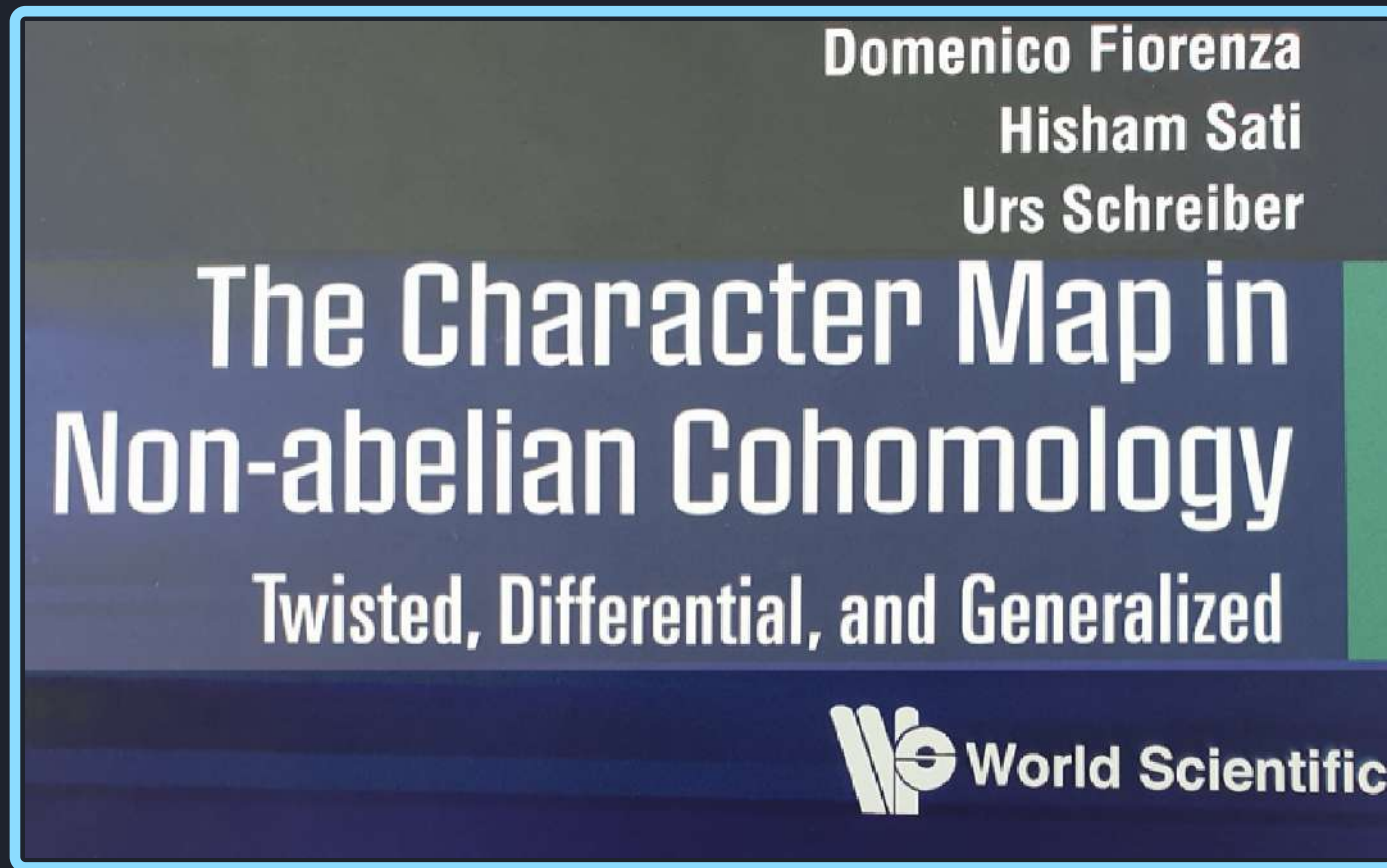

Hence global completion of a higher field theory by flux quantization is to choose \mathcal{A} such that $\mathfrak{L}\mathcal{A} \simeq \mathfrak{a}$

A *character map* associates such higher Gauß laws to classifying spaces:

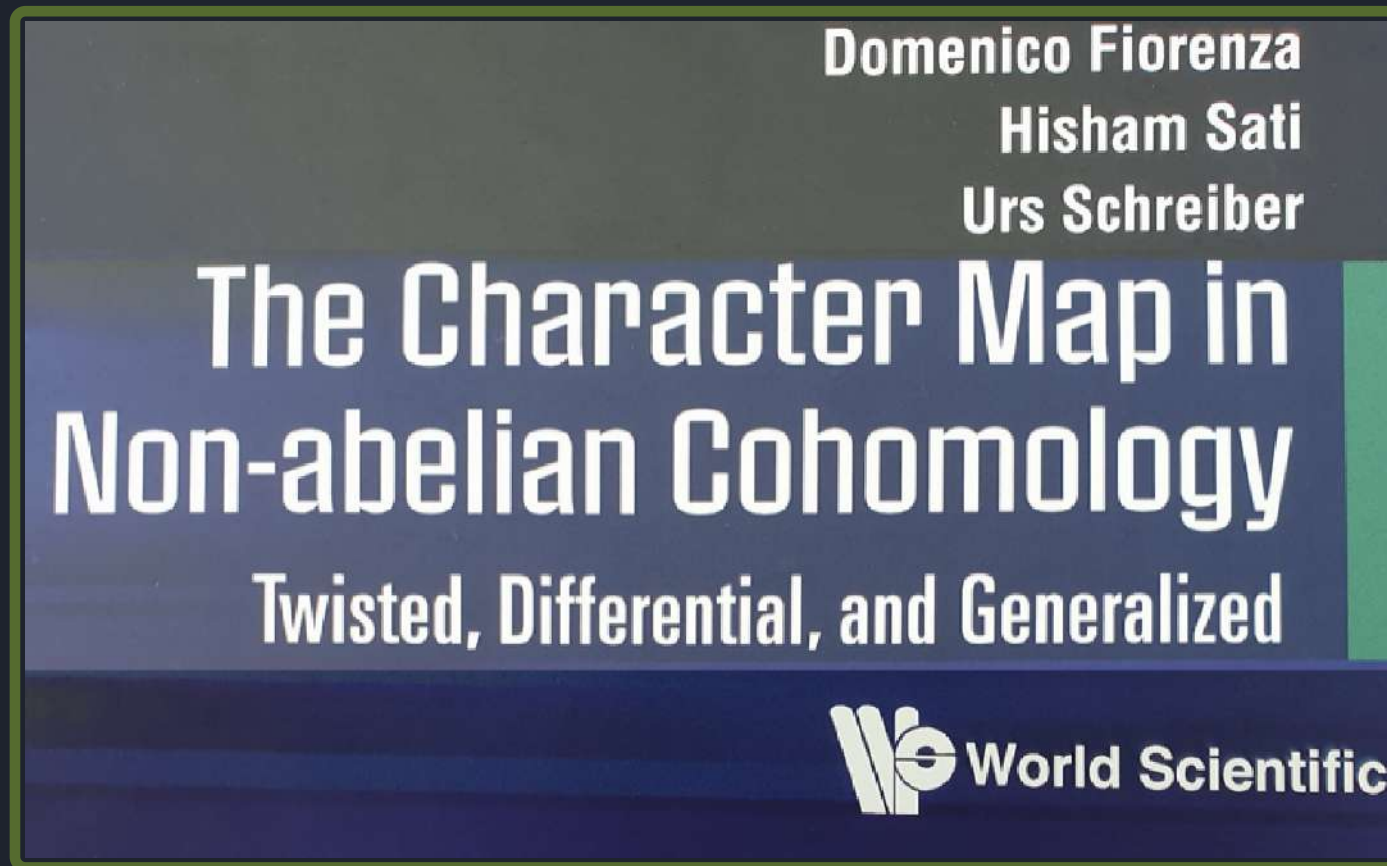

Hence global completion of a higher field theory by flux quantization is to choose \mathcal{A} such that $\mathfrak{l}\mathcal{A} \simeq \mathfrak{a}$

Conclusion so far on FQH

Conclusion so far on FQH

Conclusion

effective FQH fields



as dim reduction of

5D MCS fields



global completion

flux quantization
in 2-Cohomotopy

Conclusion so far on FQH and
outlook on the Millennium Problem:



Conclusion so far on FQH and
outlook on the Millennium Problem:

Conclusion

effective FQH fields

↓ as dim reduction of

5D MCS fields

↓ global completion

flux quantization
in 2-Cohomotopy

Speculative Outlook

hadrodynamics

↓ as dim reduction of

M5-brane WSS model (?)

↓ global completion

twisted 3-Cohomotopy,
Hypothesis H (??)

Conclusion so far on FQH and outlook on the Millennium Problem:

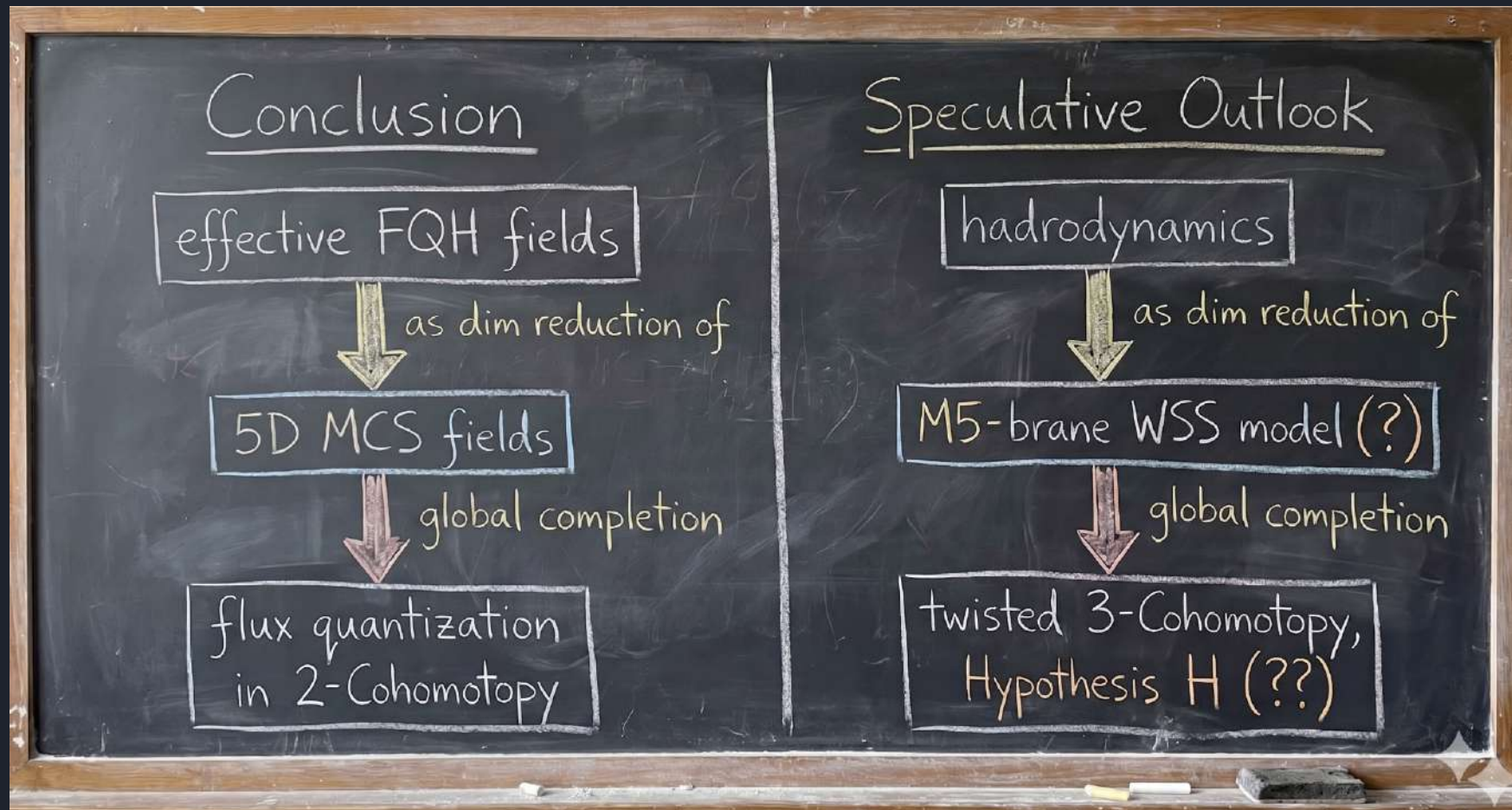

[Home](#) > [Communications in Mathematical Physics](#) > [Article](#)

Twisted Cohomotopy Implies M-Theory Anomaly Cancellation on 8-Manifolds

D. Fiorenza, H. Sati and U. Schreiber

Volume 377, pages 1961–2025, (2020) [Cite this article](#)

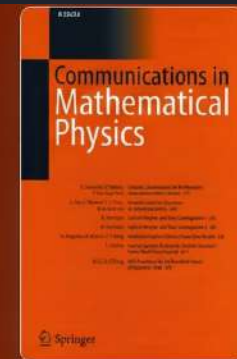

Conclusion so far on FQH and
outlook on the Millennium Problem:

Conclusion

effective FQH fields



5D MCS fields

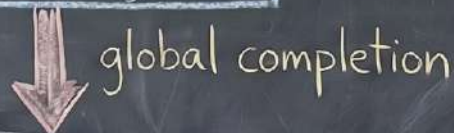

flux quantization
in 2-Cohomotopy

Speculative Outlook

hadrodynamics



M5-brane WSS model (?)

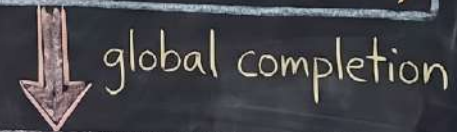

twisted 3-Cohomotopy,
Hypothesis H (??)

Conclusion so far on FQH and
outlook on the Millennium Problem:

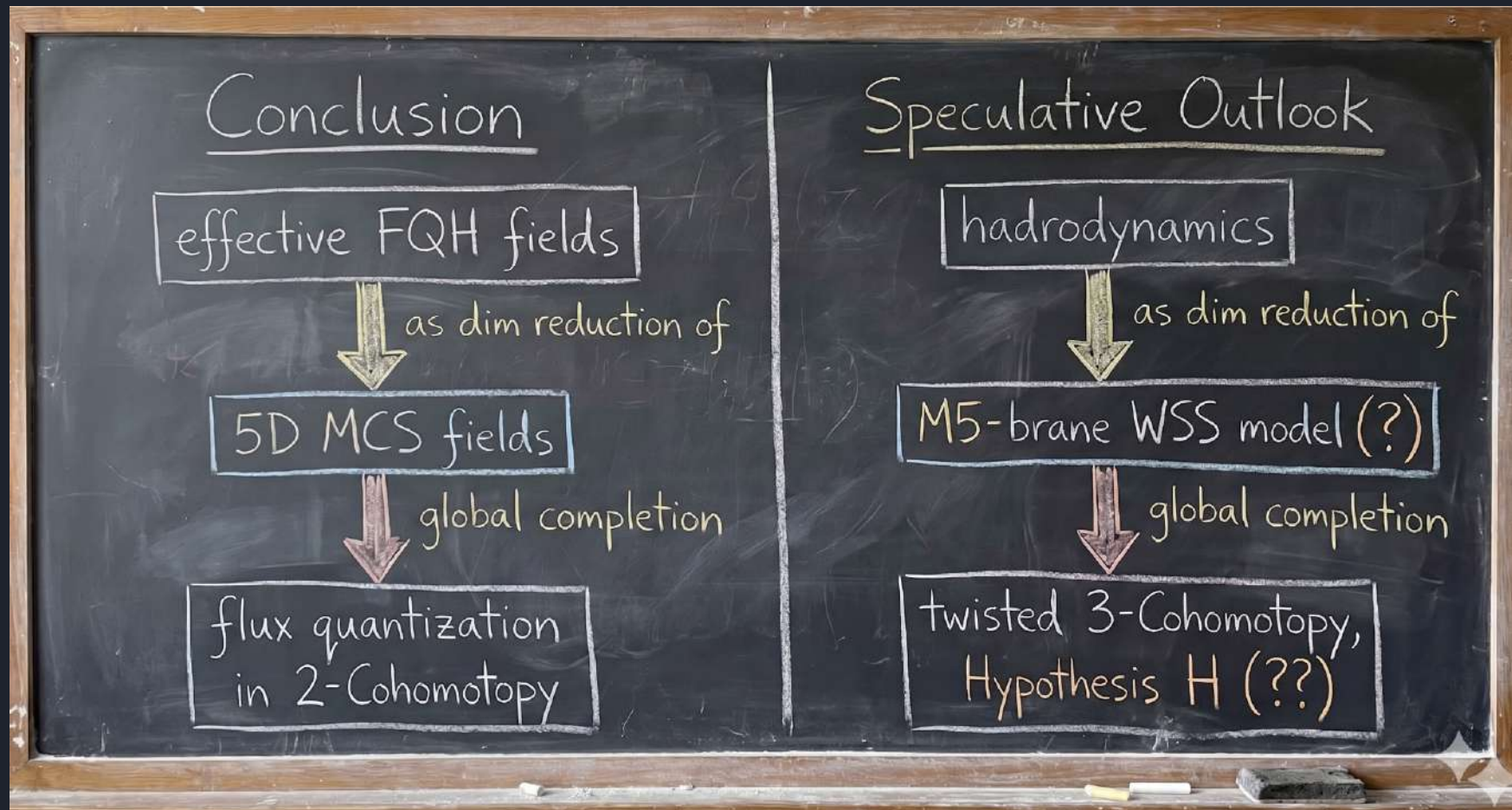

Next to look more at the mathematical framework.

Conclusion so far on FQH and
outlook on the Millennium Problem:

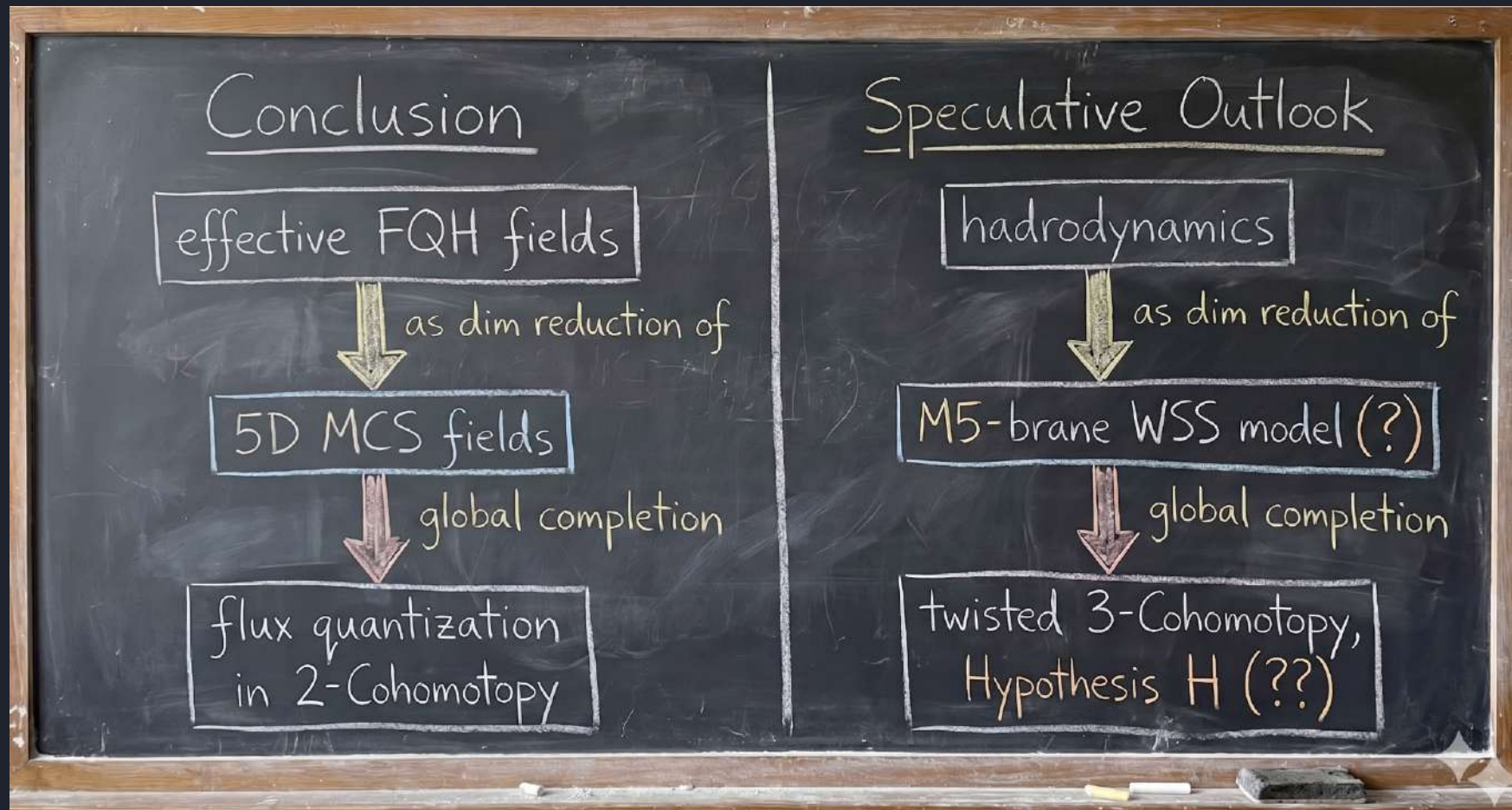

Next to look more at the mathematical framework.

Nonperturbative Phase Spaces

Nonperturbative Phase Spaces

We have seen that *physical fields* are encoded

Nonperturbative Phase Spaces

We have seen that *physical fields* are encoded locally by *flux densities* satisfying Gauß laws α

Nonperturbative Phase Spaces

We have seen that *physical fields* are encoded locally by *flux densities* satisfying Gauß laws \mathfrak{a}

$$\begin{array}{c} \text{flux} \\ \text{densities } \vec{F} \\ \downarrow \\ \Omega_{\text{cl}}^1(X; \mathfrak{a}) \end{array}$$

Nonperturbative Phase Spaces

We have seen that *physical fields* are encoded locally by *flux densities* satisfying Gauß laws \mathfrak{a} globally by *charges* within classifying space \mathcal{A}

$$\begin{array}{c} \text{flux} \\ \text{densities } \vec{F} \\ \downarrow \\ \Omega_{\text{cl}}^1(X; \mathfrak{a}) \end{array}$$

Nonperturbative Phase Spaces

We have seen that *physical fields* are encoded locally by *flux densities* satisfying Gauß laws \mathfrak{a} globally by *charges* within classifying space \mathcal{A}

$$\begin{array}{ccc} & \text{charges} & \\ & \chi \longrightarrow & \text{Map}(X, \mathcal{A}) \\ & & \\ \text{flux} & & \\ \text{densities} & \vec{F} & \\ & \downarrow & \\ & \Omega_{\text{cl}}^1(X; \mathfrak{a}) & \end{array}$$

Nonperturbative Phase Spaces

We have seen that *physical fields* are encoded locally by *flux densities* satisfying Gauß laws \mathfrak{a} globally by *charges* within classifying space \mathcal{A}

The nonperturbative field content must combine these.

$$\begin{array}{ccc} & \text{charges} & \\ & \chi \longrightarrow & \text{Map}(X, \mathcal{A}) \\ & & \\ \text{flux} & & \\ \text{densities} & \vec{F} & \\ & \downarrow & \\ & \Omega_{\text{cl}}^1(X; \mathfrak{a}) & \end{array}$$

Nonperturbative Phase Spaces

We have seen that *physical fields* are encoded locally by *flux densities* satisfying Gauß laws \mathfrak{a} globally by *charges* within classifying space \mathcal{A}

The nonperturbative field content must combine these.

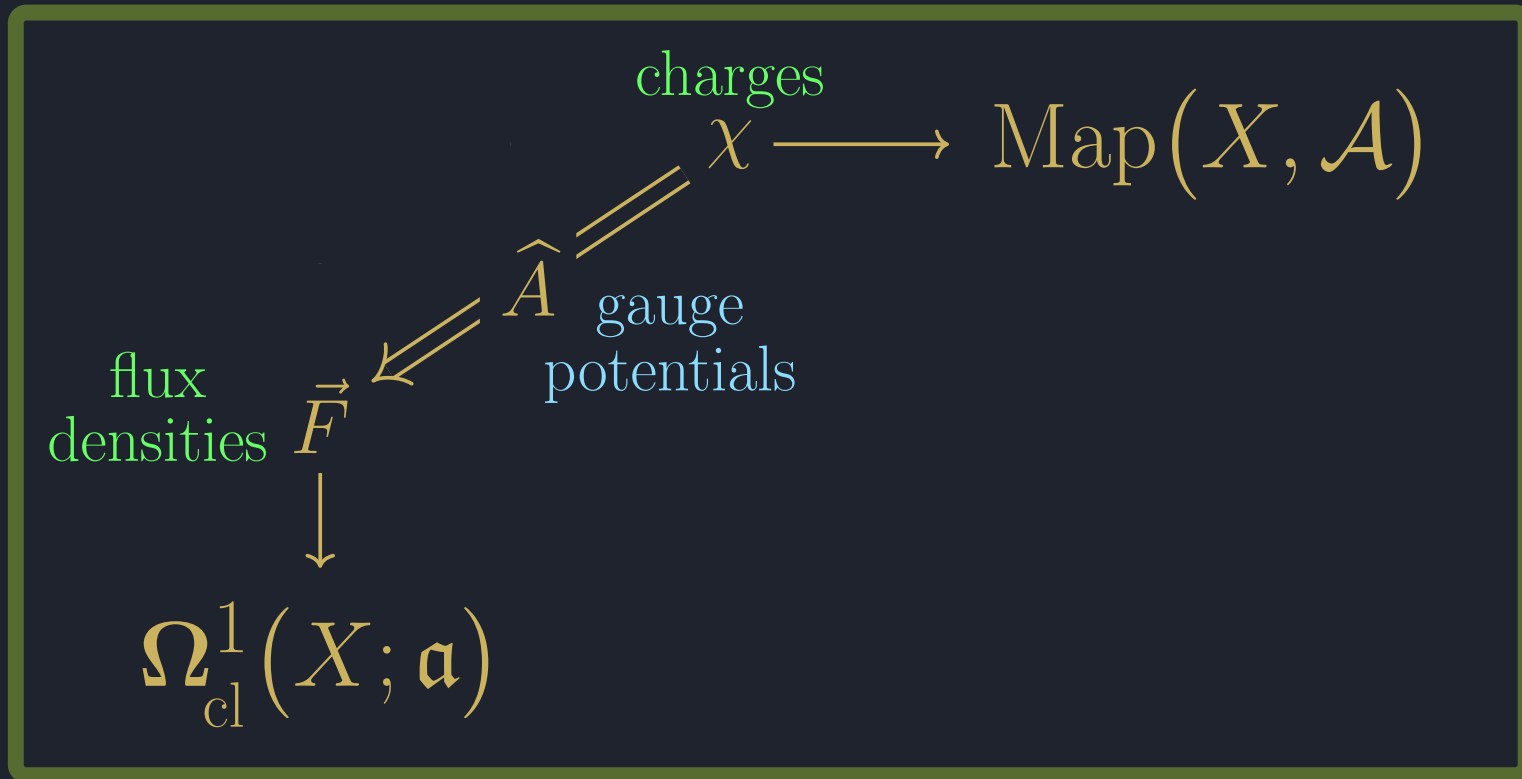

Nonperturbative Phase Spaces

We have seen that *physical fields* are encoded locally by *flux densities* satisfying Gauß laws \mathfrak{a} globally by *charges* within classifying space \mathcal{A}

The nonperturbative field content must combine these.

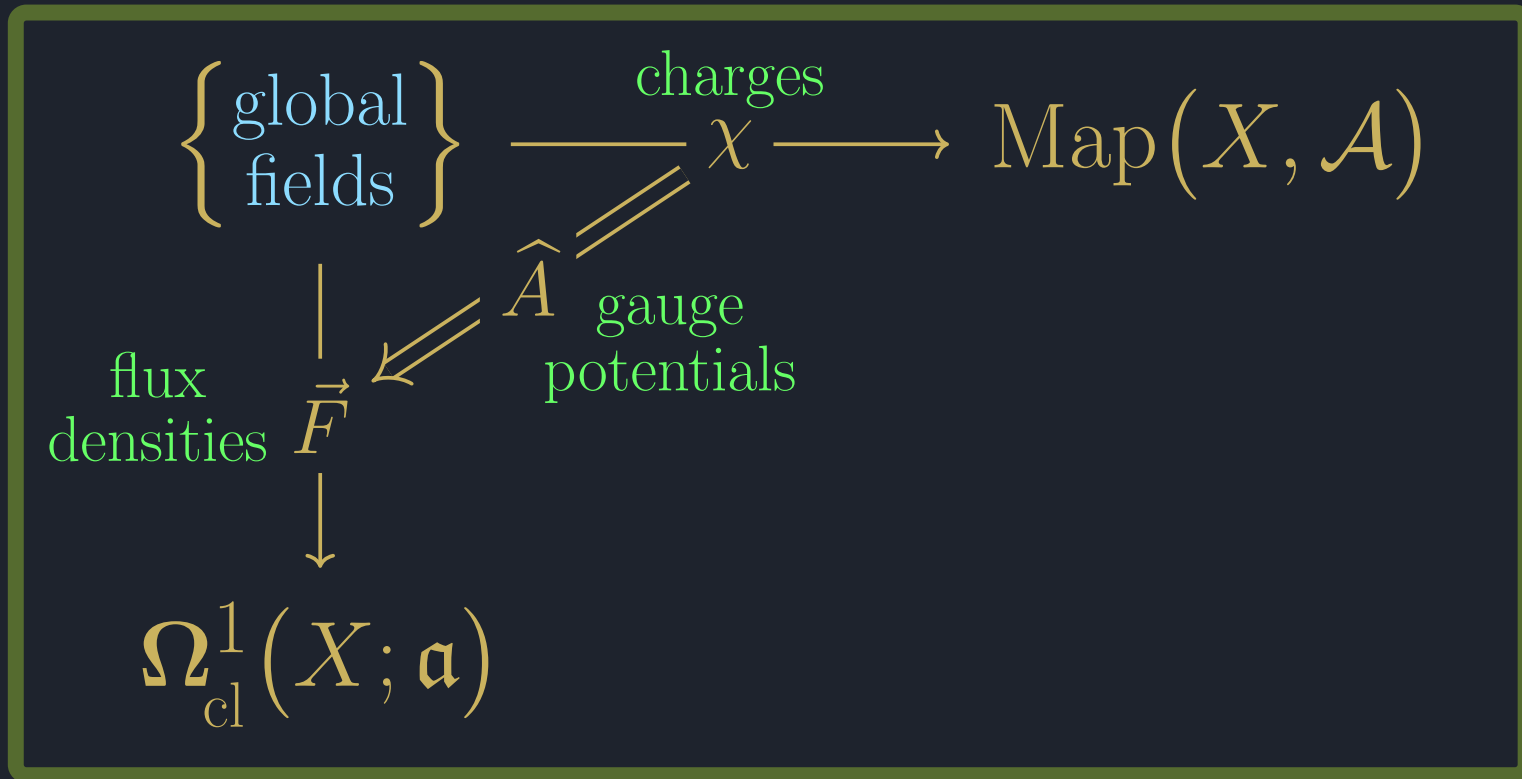

Nonperturbative Phase Spaces

We have seen that *physical fields* are encoded locally by *flux densities* satisfying Gauß laws \mathfrak{a} globally by *charges* within classifying space \mathcal{A}

The nonperturbative field content must combine these.

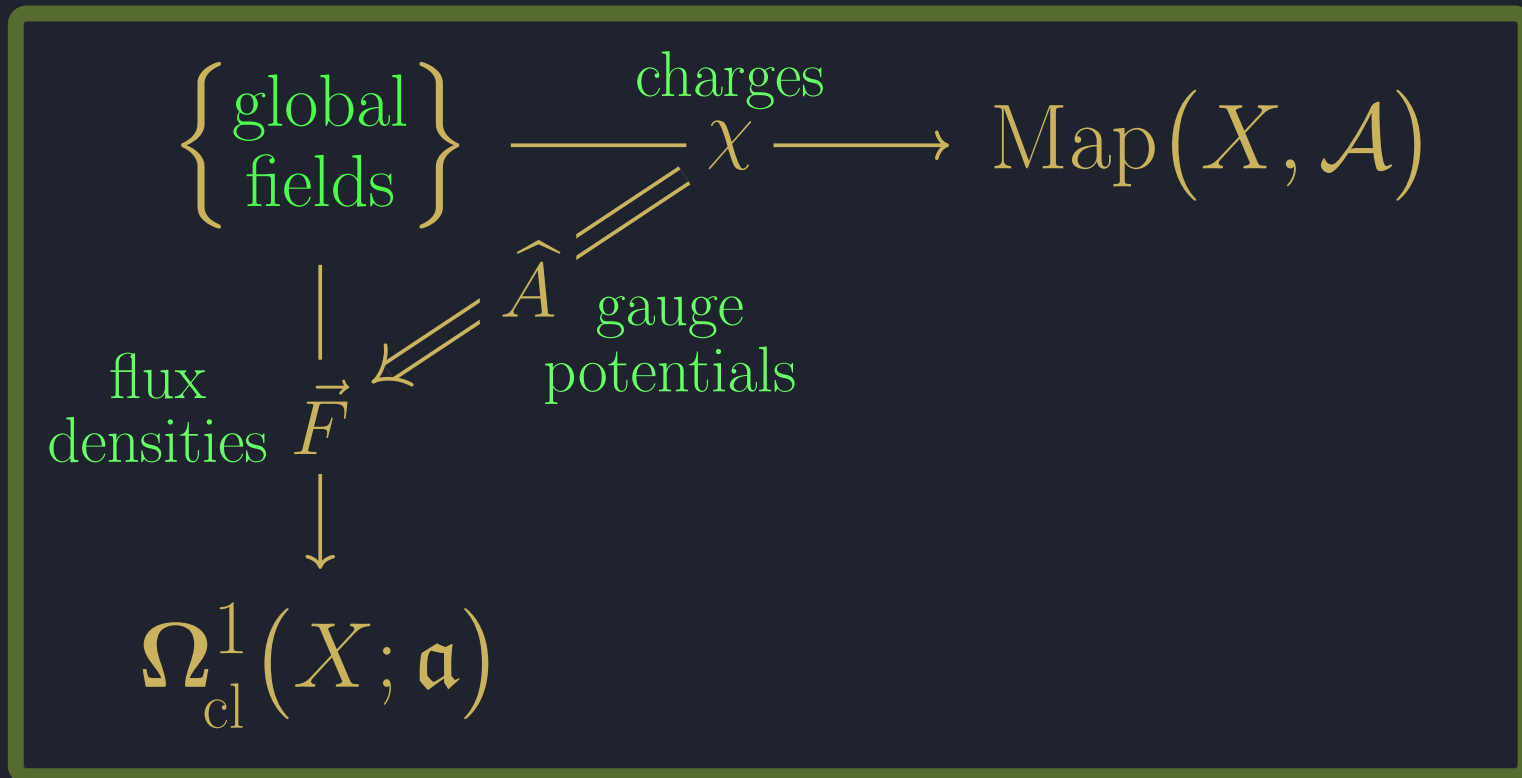

This exists (only) in a novel universe of mathematics:

Nonperturbative Phase Spaces

We have seen that *physical fields* are encoded locally by *flux densities* satisfying Gauß laws \mathfrak{a} globally by *charges* within classifying space \mathcal{A}

The nonperturbative field content must combine these.

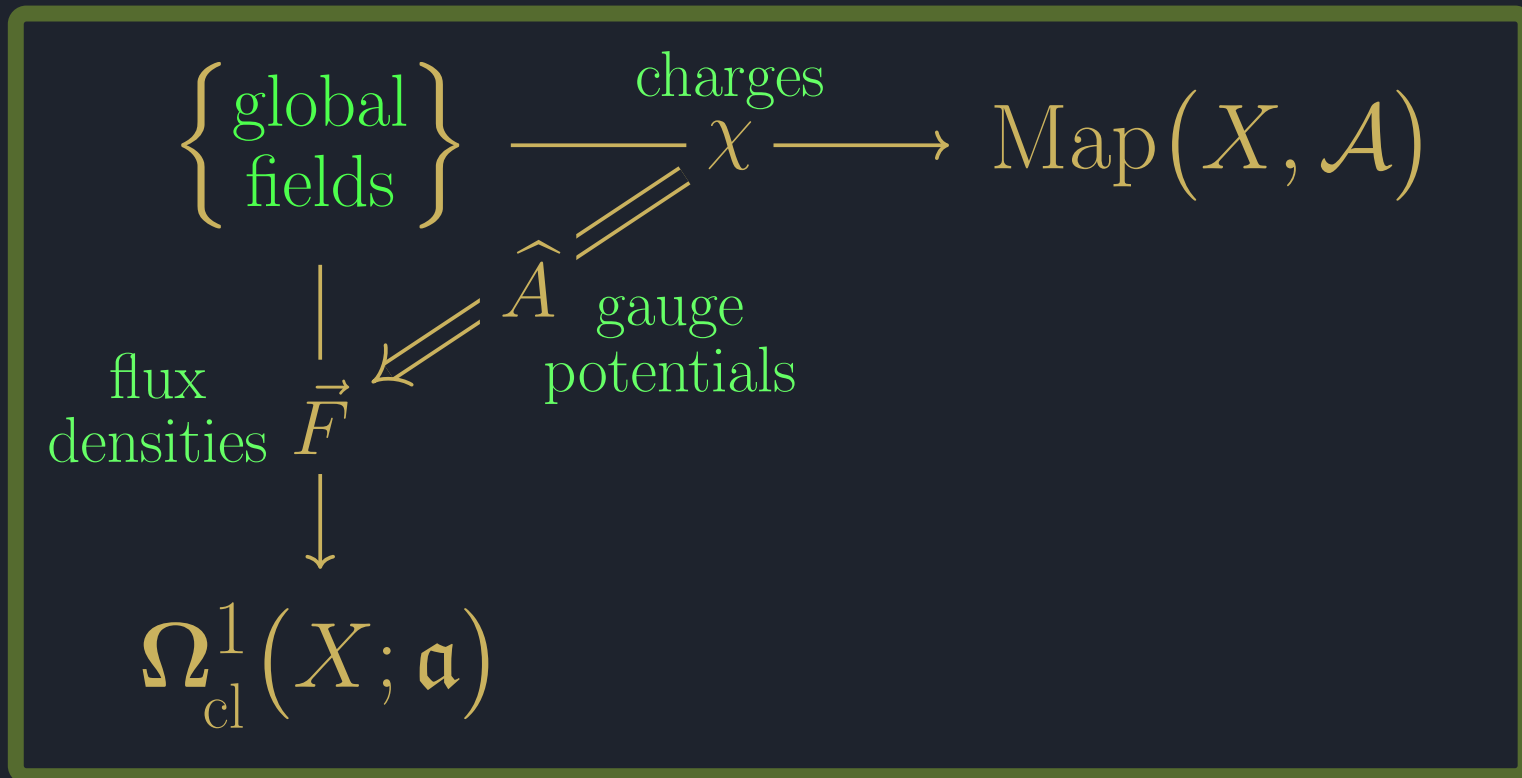

This exists (only) in a novel universe of mathematics:
It is a homotopy pullback

Nonperturbative Phase Spaces

We have seen that *physical fields* are encoded locally by *flux densities* satisfying Gauß laws \mathfrak{a} globally by *charges* within classifying space \mathcal{A}

The nonperturbative field content must combine these.

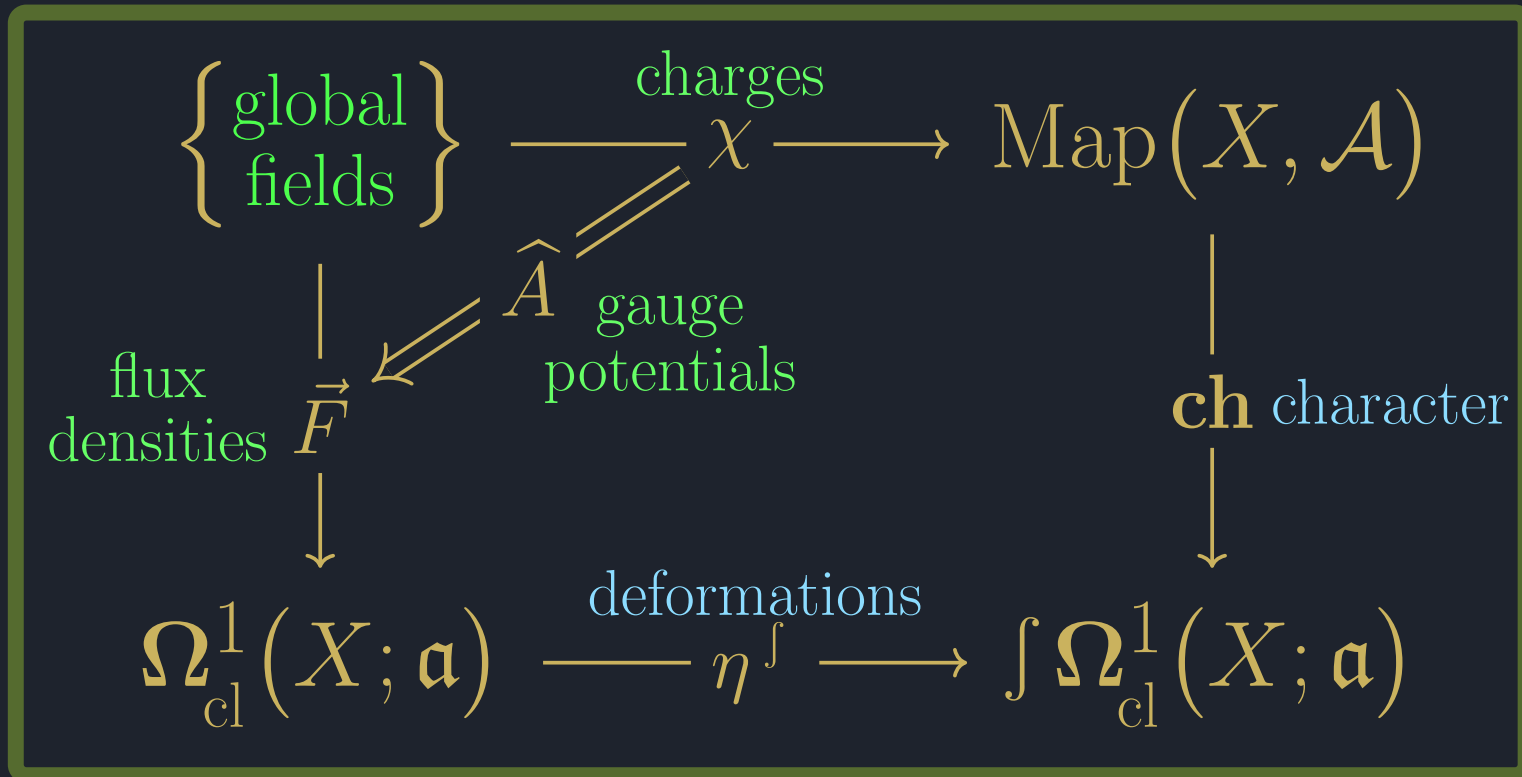

This exists (only) in a novel universe of mathematics:
It is a homotopy pullback

Nonperturbative Phase Spaces

We have seen that *physical fields* are encoded locally by *flux densities* satisfying Gauß laws \mathfrak{a} globally by *charges* within classifying space \mathcal{A}

The nonperturbative field content must combine these.

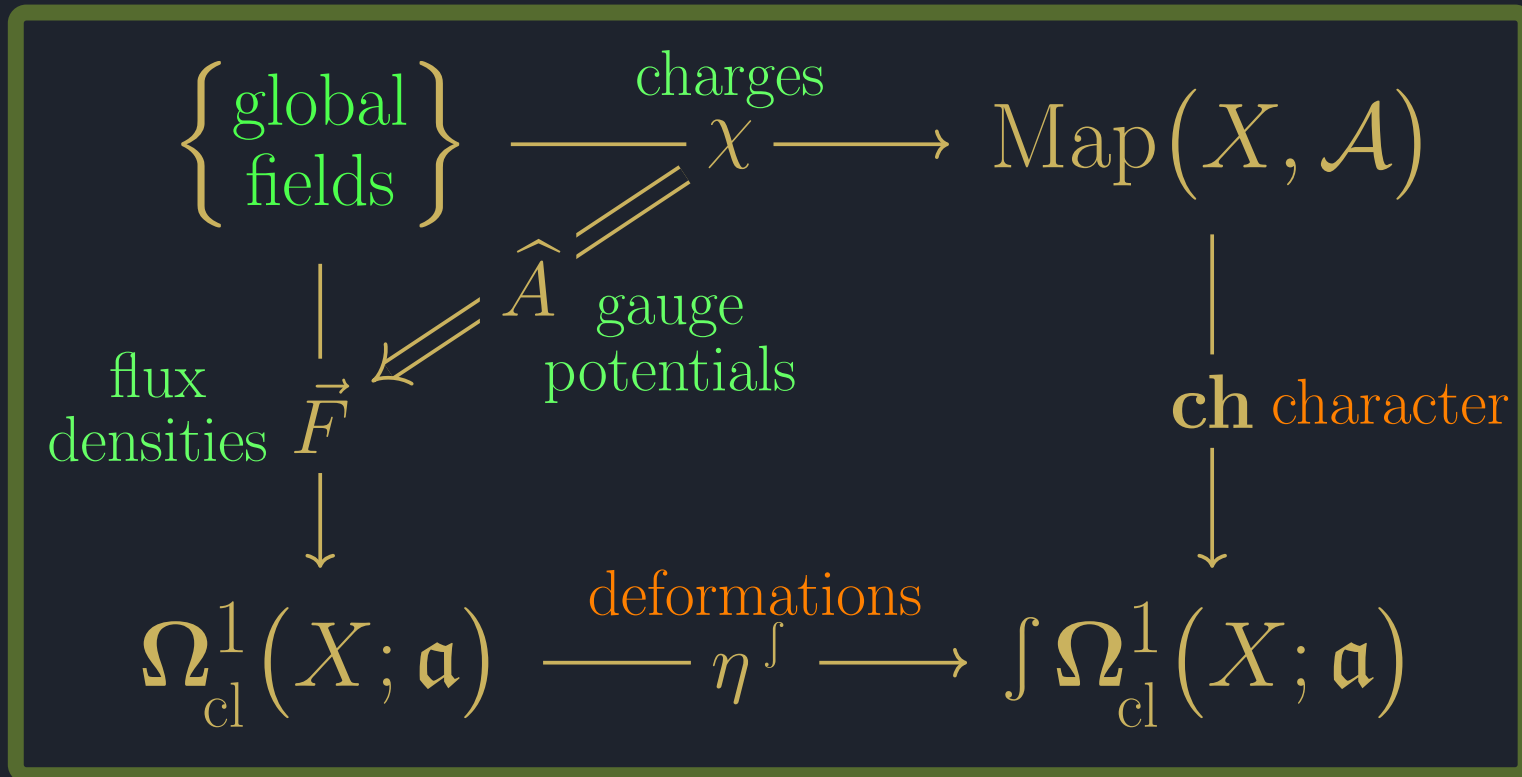

This exists (only) in a novel universe of mathematics:
It is a homotopy pullback in a *higher geometric topos*.

Nonperturbative Phase Spaces

We have seen that *physical fields* are encoded locally by *flux densities* satisfying Gauß laws \mathfrak{a} globally by *charges* within classifying space \mathcal{A}

The nonperturbative field content must combine these.

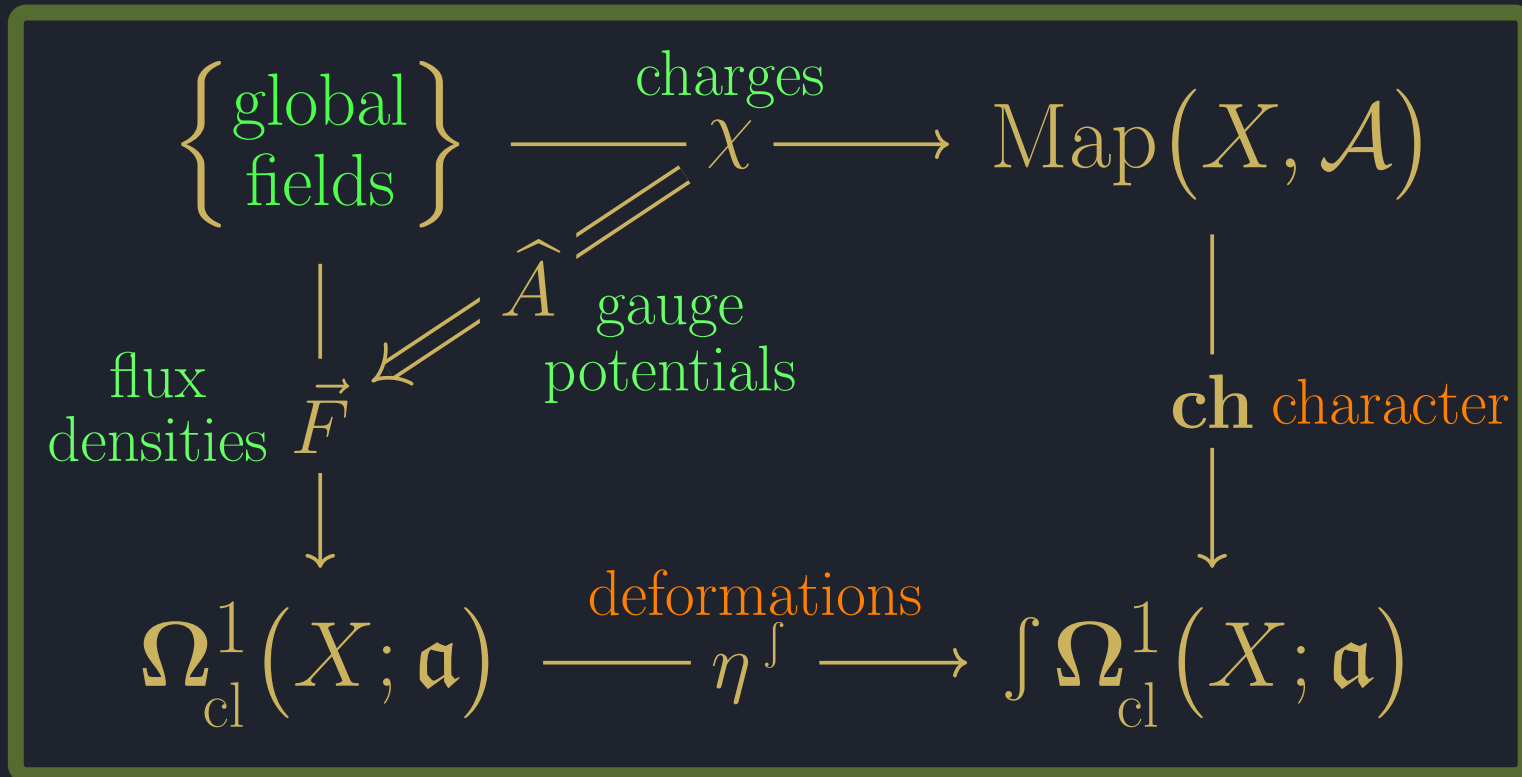

This exists (only) in a novel universe of mathematics:
It is a homotopy pullback in a *higher geometric topos*.

Nonperturbative Phase Spaces

We have seen that *physical fields* are encoded locally by *flux densities* satisfying Gauß laws and globally by *charges* within classifying space \mathcal{A}

The nonperturbative field content must combine these.

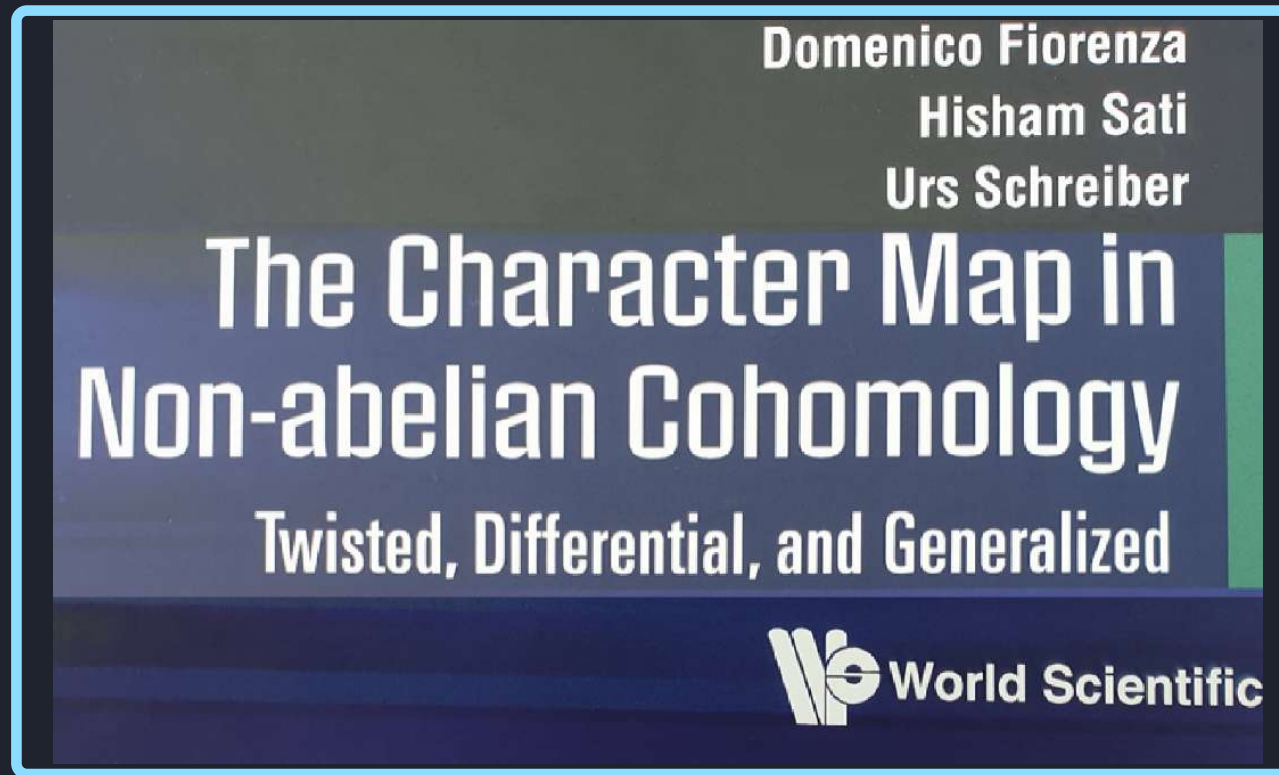

This exists (only) in a novel universe of mathematics:
It is a homotopy pullback in a *higher geometric topos*.

Nonperturbative Phase Spaces

We have seen that *physical fields* are encoded locally by *flux densities* satisfying Gauß laws and globally by *charges* within classifying space \mathcal{A}

The nonperturbative field content must combine these.

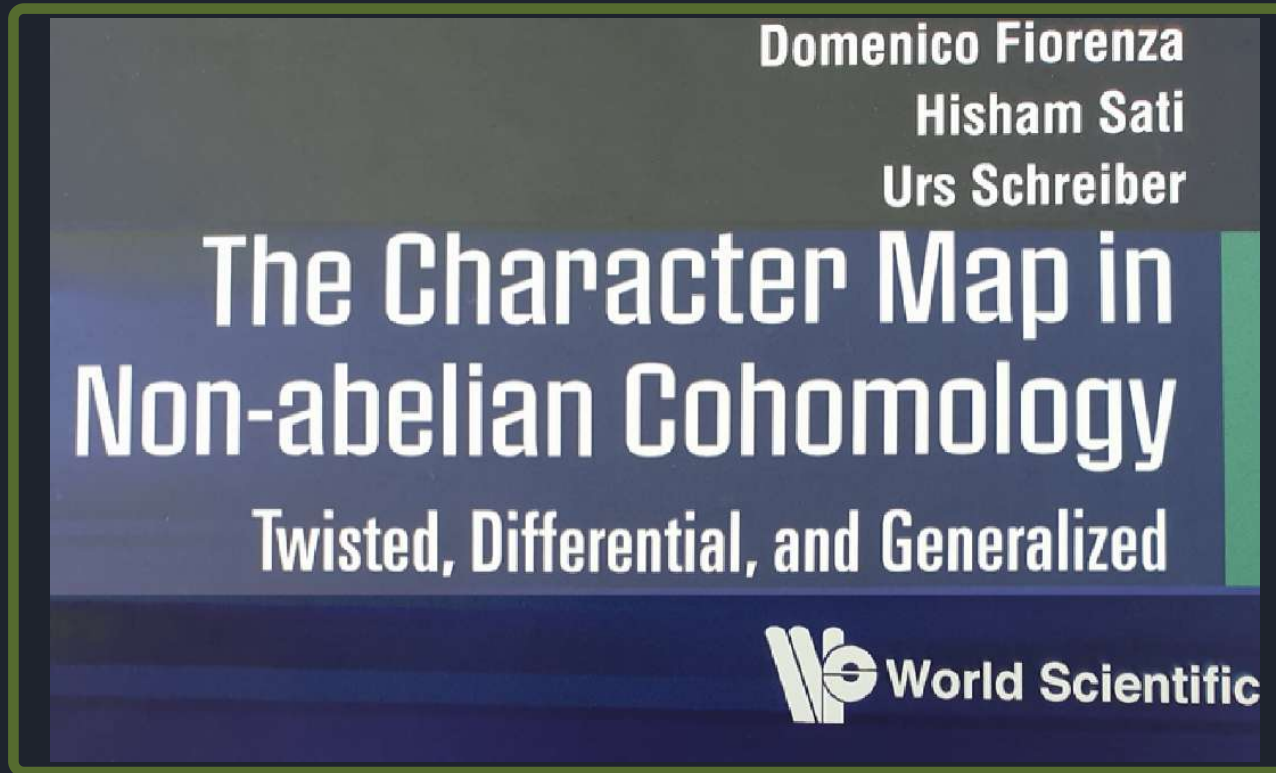

This exists (only) in a novel universe of mathematics:
It is a homotopy pullback in a *higher geometric topos*.

FLUX
DENSITIES

CHARGES

GEOMETRY

Geometric
Homotopy
(Higher Topos Theory)

Homotopy

Thus to formulate nonperturbative physics in higher topoi

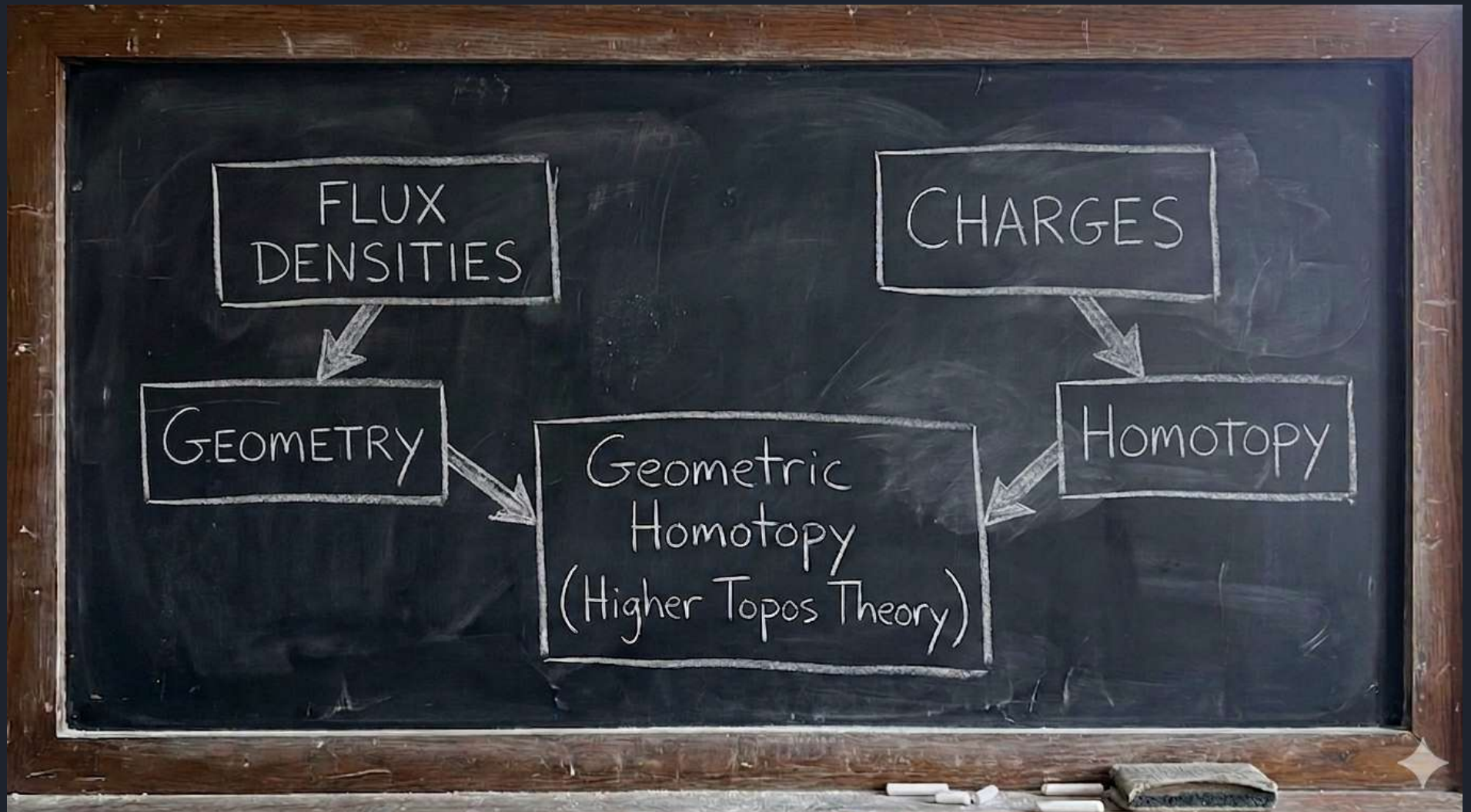

Thus to formulate nonperturbative physics in higher topoi



Encyclopedia of Mathematical
Physics (Second Edition)

Volume 4, 2025, Pages 62-76

Higher Topos Theory in Physics

Urs Schreiber

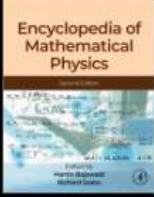

Thus to formulate nonperturbative physics in higher topoi

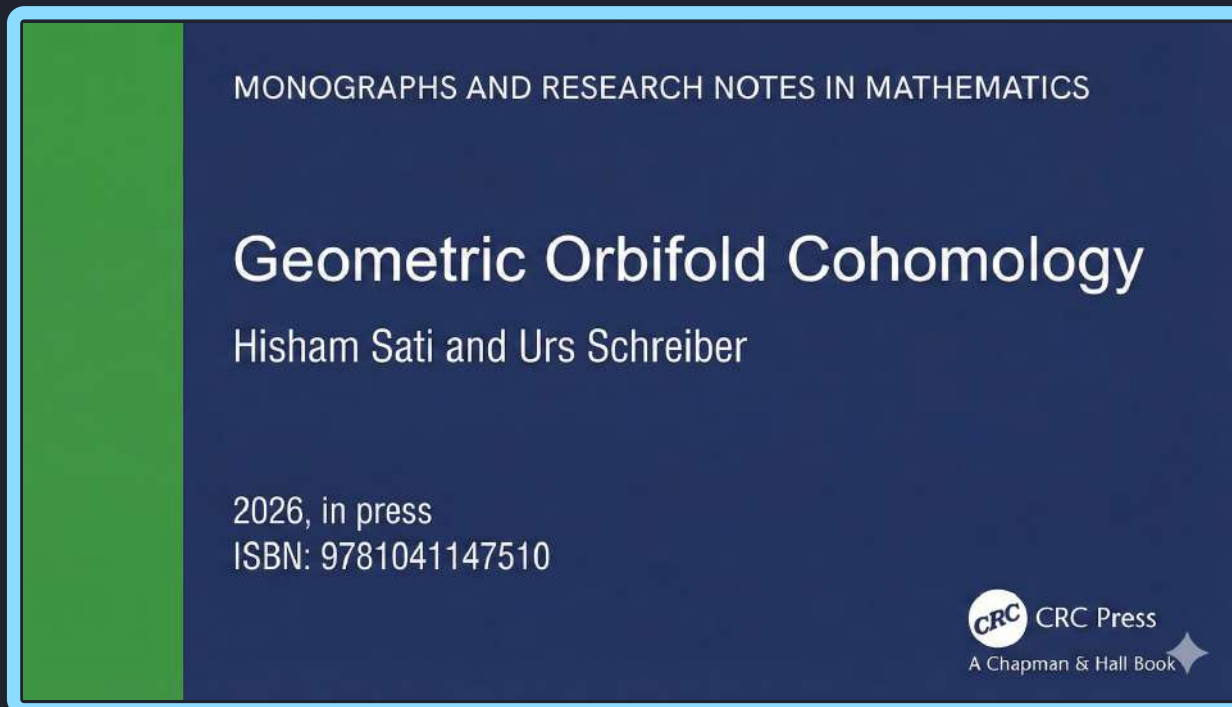
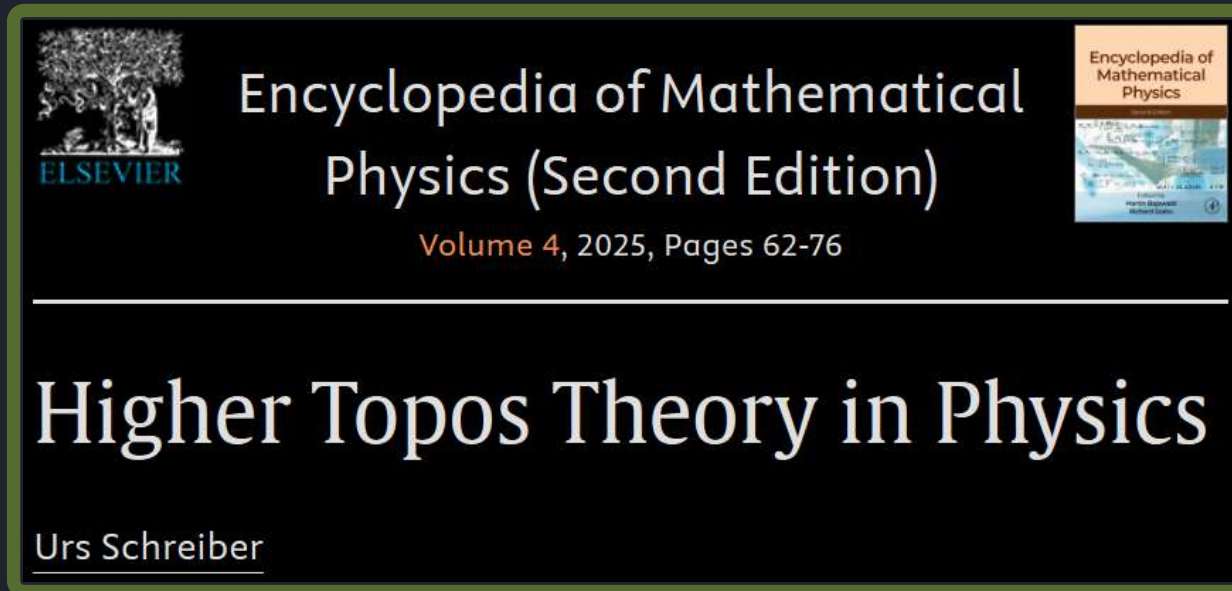

Thus to formulate nonperturbative physics in higher topoi

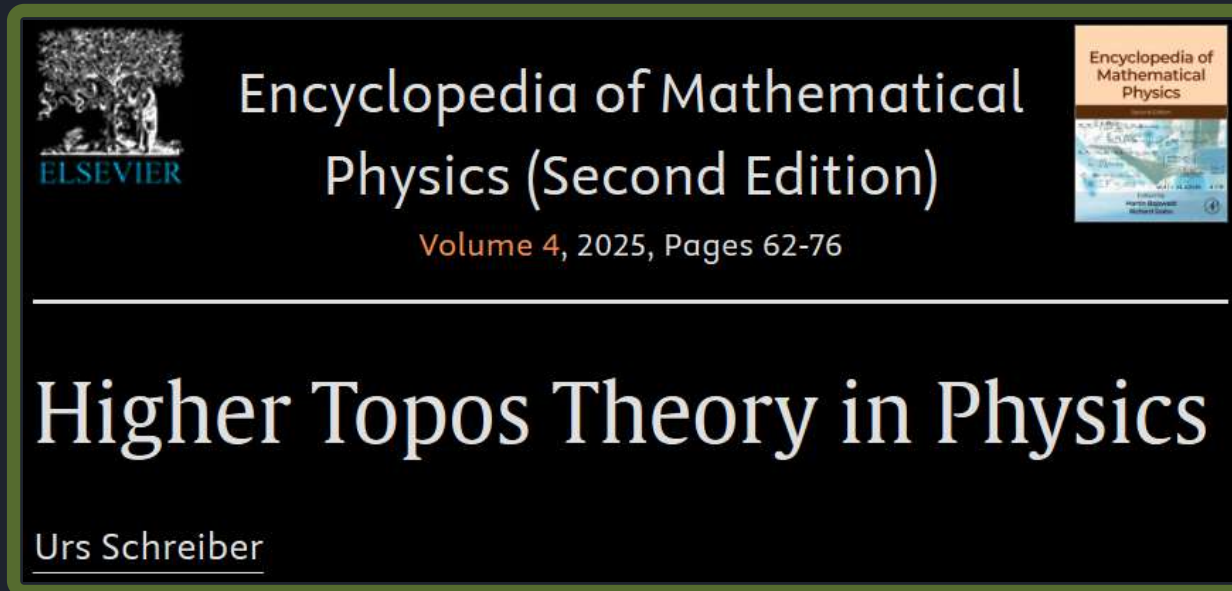

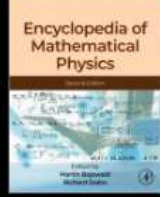
 **Encyclopedia of Mathematical
Physics (Second Edition)** 
Volume 4, 2025, Pages 62-76

Higher Topos Theory in Physics

Urs Schreiber

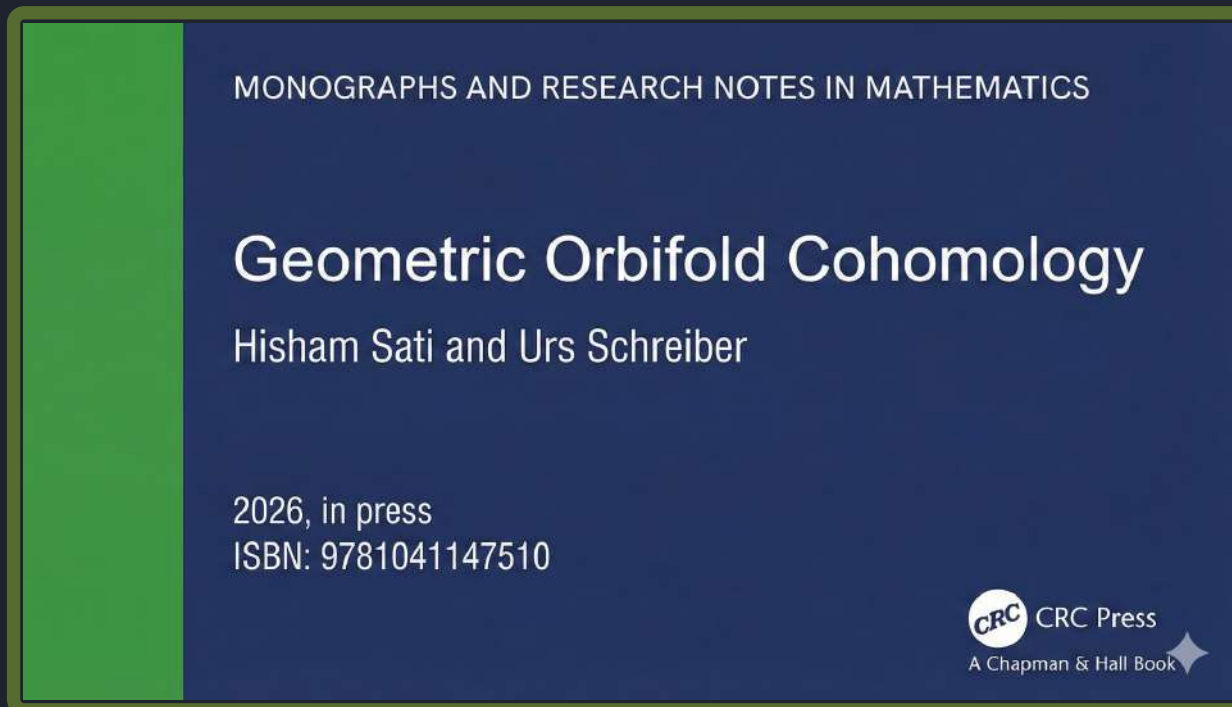

MONOGRAPHS AND RESEARCH NOTES IN MATHEMATICS

Geometric Orbifold Cohomology

Hisham Sati and Urs Schreiber

2026, in press
ISBN: 9781041147510

 CRC Press
A Chapman & Hall Book

Towards a programming language for topological physics

Even though higher topoi have a reputation of being involved
this is really a property of their set-theoretic models

Towards a programming language for topological physics

Even though higher topoi have a reputation of being involved
this is really a property of their set-theoretic models
indeed, the abstract language of higher topoi is so neat
that it even exists as a programming language: **HoTT**

Towards a programming language for topological physics

Even though higher topoi have a reputation of being involved this is really a property of their set-theoretic models indeed, the abstract language of higher topoi is so neat that it even exists as a programming language: **HoTT**

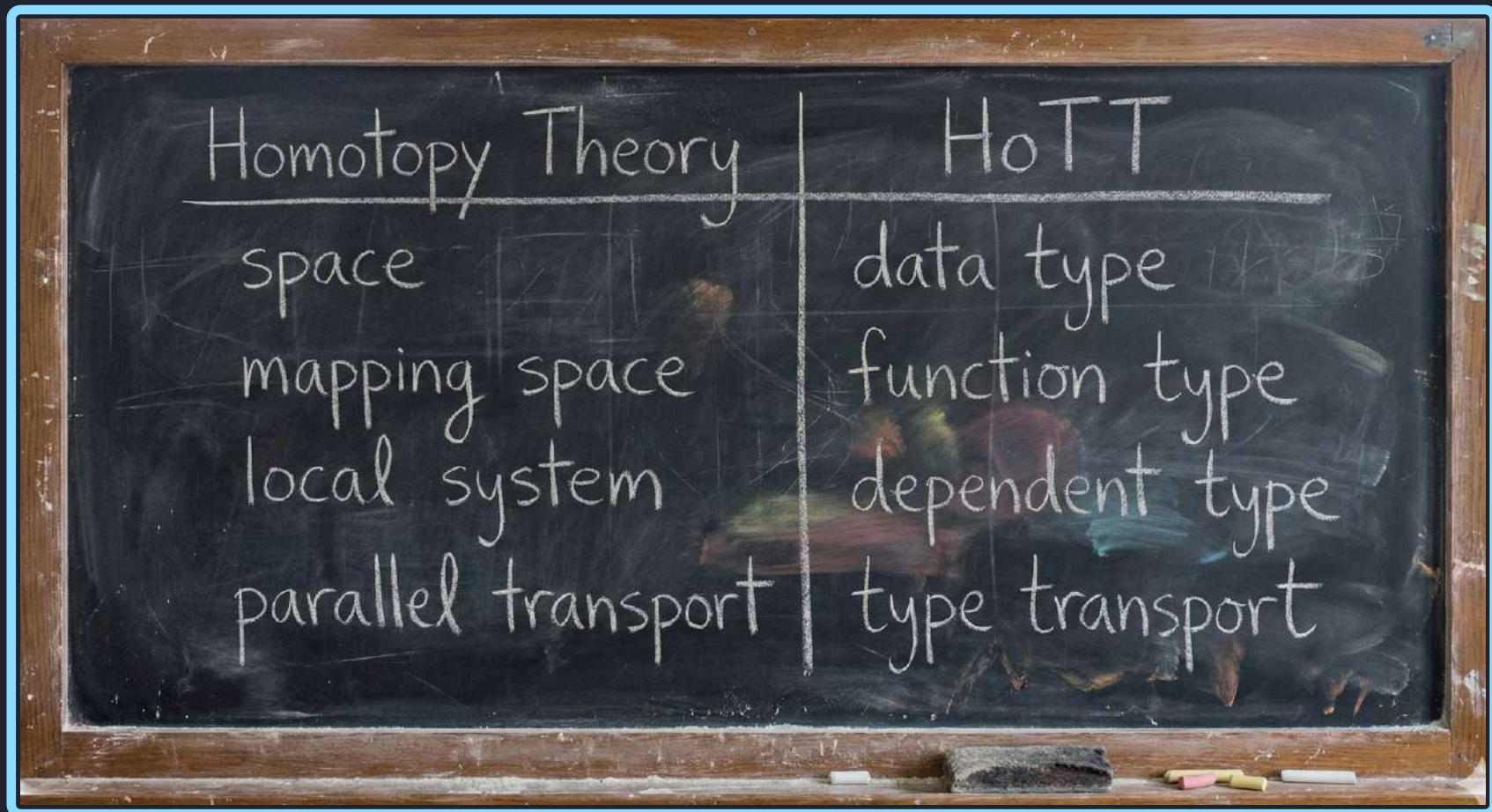

Homotopy Theory	HoTT
space	data type
mapping space	function type
local system	dependent type
parallel transport	type transport

Towards a programming language for topological physics

Even though higher topoi have a reputation of being involved this is really a property of their set-theoretic models indeed, the abstract language of higher topoi is so neat that it even exists as a programming language: **HoTT**

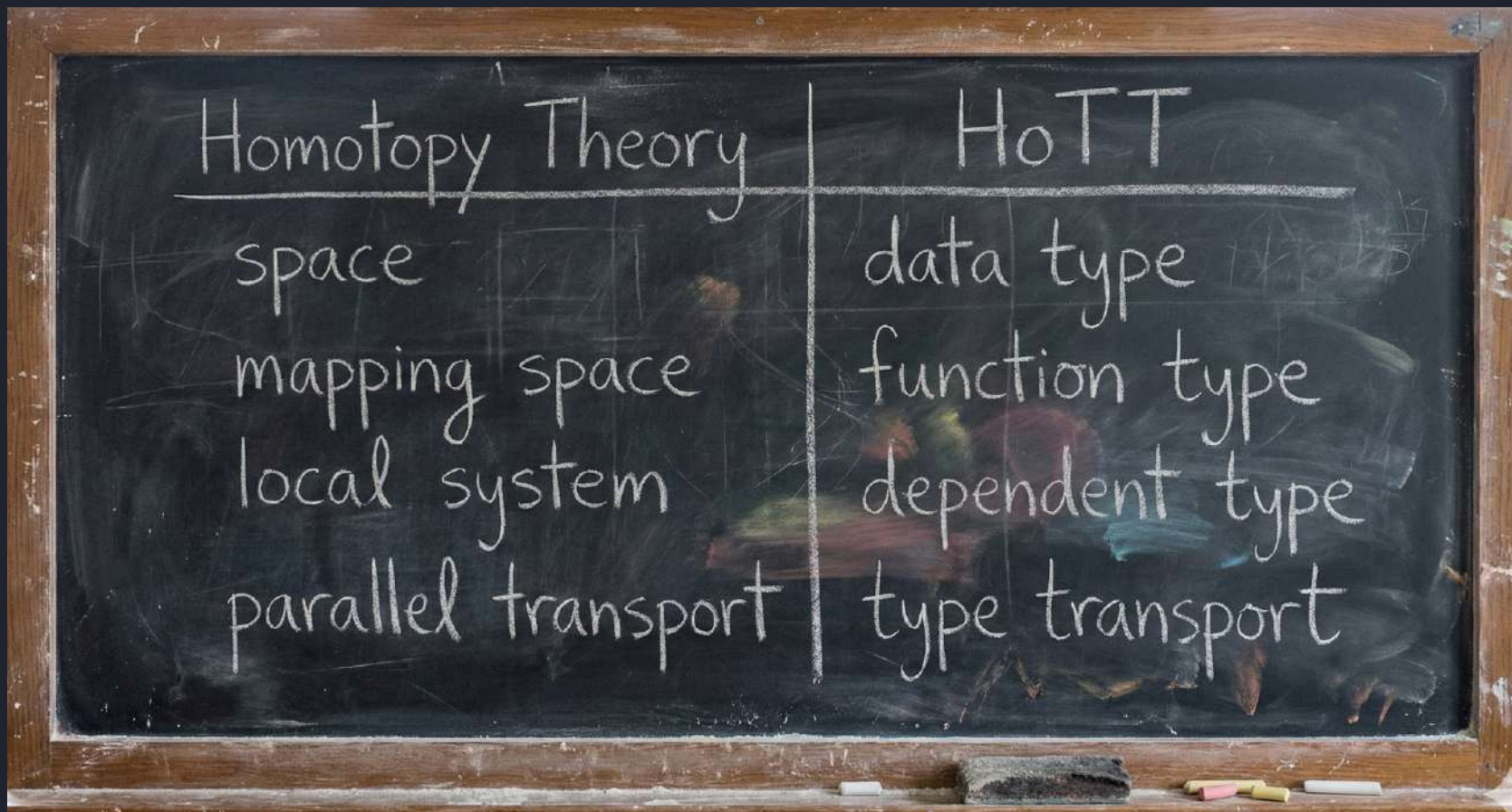

A chalkboard with a wooden frame, divided into two columns by a vertical line. The left column is titled 'Homotopy Theory' and the right column is titled 'HoTT'. Both titles are underlined. The table lists corresponding concepts in each field.

<u>Homotopy Theory</u>	<u>HoTT</u>
space	data type
mapping space	function type
local system	dependent type
parallel transport	type transport

This reflects exactly the structures that showed up above.

Towards a programming language for topological physics

Even though higher topoi have a reputation of being involved this is really a property of their set-theoretic models indeed, the abstract language of higher topoi is so neat that it even exists as a programming language: HoTT

Communications in Mathematical Physics

D.J. Myers, H. Sati and U. Schreiber:
Topological Quantum Gates in HoTT
Commun. Math. Phys. **405**, 172 (2024)
Springer Nature

 Springer Nature



Summary and Outlook

Grand Physics Problem of 21st Century:
nonperturbative global physics

Summary and Outlook

Grand Physics Problem of 21st Century:
nonperturbative global physics

Open Problem 1:

Confined hadrodynamics:

unknown hadronic corrections

infect all SM processes

Summary and Outlook

Grand Physics Problem of 21st Century:
nonperturbative global physics

Open Problem 1:

Confined hadrodynamics:
unknown hadronic corrections
infect all SM processes

Open Problem 2:

Strongly correlated electrons:
need control over topological order
for meaningful quantum computing

Summary and Outlook

Grand Physics Problem of 21st Century:
nonperturbative global physics

Open Problem 1:

Confined hadrodynamics:
unknown hadronic corrections
infect all SM processes

Open Problem 2:

Strongly correlated electrons:
need control over topological order
for meaningful quantum computing

Attack strategy:

- (1) Embed into higher dimensional higher field theories
- (2) Globally complete these by proper flux quantization

Summary and Outlook

Grand Physics Problem of 21st Century:
nonperturbative global physics

Open Problem 1:

Confined hadrodynamics:
unknown hadronic corrections
infect all SM processes

Open Problem 2:

Strongly correlated electrons:
need control over topological order
for meaningful quantum computing

Attack strategy:

- (1) Embed into higher dimensional higher field theories
- (2) Globally complete these by proper flux quantization

Necessary math is: **geometric homotopy** (higher topoi),
a new form of global mathematics for nonperturbative physics

Summary and Outlook

Grand Physics Problem of 21st Century:
nonperturbative global physics

Open Problem 1:

Confined hadrodynamics:
unknown hadronic corrections
infect all SM processes

Open Problem 2:

Strongly correlated electrons:
need control over topological order
for meaningful quantum computing

Attack strategy:

- (1) Embed into higher dimensional higher field theories
- (2) Globally complete these by proper flux quantization

Necessary math is: **geometric homotopy** (higher topoi),
a new form of global mathematics for nonperturbative physics

Rich in phenomena but extremely neat in the abstract (**HoTT**).
Possibly the 21st century math for the millennium problem of physics.

Summary and Outlook

Grand Physics Problem of 21st Century:
nonperturbative global physics

Open Problem 1:

Confined hadrodynamics:
unknown hadronic corrections
infect all SM processes

Open Problem 2:

Strongly correlated electrons:
need control over topological order
for meaningful quantum computing

Attack strategy:

- (1) Embed into higher dimensional higher field theories
- (2) Globally complete these by proper flux quantization

Necessary math is: **geometric homotopy** (higher topoi),
a new form of global mathematics for nonperturbative physics

Rich in phenomena but extremely neat in the abstract (**HoTT**).
Possibly the 21st century math for the millennium problem of physics.

Urs Schreiber

New York University Abu Dhabi
Center for Quantum & Topological
Systems

The End

materials at: ncatlab.org/schreiber/show/WIKO+2026

